

TOOL & EQUIPMENT CATALOG

www.tallmanequipment.com

Tallman Equipment proudly offers quality tools & equipment from these manufacturers

32 North	DeWalt	Lakeland Reflective App'l	Rubbermaid
Alcoa	Dicke Tool	Laser Technology	Rycom Instruments
AEMC	Dillon	Leidy Tool	
AlturnaMats	Dixie Industries	Lewis Manufacturing	Safety Hooks
Amercable	Dremel	Lift-All	Safeway Products
American Polywater	Duff Norton	Liftons	Salisbury
American Tool	Eagle Line Tools	Lincoln Hoist	Samson Rope
Amprobe	Echo	Lindsey Manufacturing	Sauber Manufacturing
Anderson	Eclipse Enterprises	Little Mule	Scientific Developments
Armstrong	Electroline	Lowell	Schonstedt Instruments
Arnett Industries	Esmet	Lufkin	Sellstrom Manufacturing
Apex	Estex	Lug All	Sensorlink Corp.
ATP / Hy-Tech Machine		Lindsey Manufacturing	Seymour Manufacturing
	Fairmont	M & A Products	Skil
B & A Manufacturing	Fargo	Maasdam	Skookum
Band-It	Fein Power Tools	MacLean Power Systems	Slingco
Bartlett Industries	FOF	Marketing Displays, Inc.	Snap-On Tools
Bashlin	FuseBuddy	Mechanix Wear	Speed Systems
Bethea Tool	G & R Solutions	Michigan Ladder	SPX Power
Bevins	Gear Wrench	Milwaukee Tool	Stanley Hydraulics
Bierer & Associates	Gilmour	Morpac	Streamlight
Black & Decker	GMP	Mutual Industries	T.S.E. International
Bosch	Golight	Nasco	Tana Wire Markers
Brunner & Lay	Green Bull	Naval Company	Tesmec
Buckingham	Greenlee	New Draulics	ThunderBolt
Burndy	Grey Pneumatics		Tiiger, Inc.
Campbell Chain	Guardian Fall Protection	Okonite	Timco Instruments
Campbell Specialty	Gunnebo Johnson	Oshkosh Tools	Tinker Tools
Cembre		Orion Ropeworks	Traffix Devices
Cementex	Hastings		Tulsa Power
Chance	HD Elecgtric	Parker	Tyco
Channel Lock	Hisco	Peavy	TwisTarp
Chicago Hardware	Hit Tools	Pelsue	TwisTool
Chicago Pneumatic	Hogg Davis	Pengo	Underwater Kinetics
Chicago Protective App'l	Hubbell Power Systems	Plastic Techniques	Unison Enterprises
CM Rigging		Ply-Tech	Utility Solutions
Coffing Hoists	Ideal	Porter Cable	Utility Tool & Body
Columbus McKinnon	Irwin	Prestolite	
Condux International		Proline	Veto Pro Pac
Continental Power	Jackson Safety	Proto	
Cooper Power Systems	Jameson	PT Coupling	Warren Heim
Cooper Tools	JBC Safety	Pull'R Holdings	Wellington
Council Tool	Jancy		Werner Ladder
Crosby Group	Jenny Tools	R & P Innovations	Wisman
Current Tools		Rainbow Technologies	Wood Owl
	Kearney	Rauckman Utility	Wright Tools
DCD Design	Kellems	Ridgid (Ridge)	
DDIN	Keson Industries	Ripley	Yale Cordage
DeMark	Klein Tools	Rite In The Rain	
Descent Control	Knopp	Rotatape	
DeWalt	Kunz Glove	Roper Whitney	

WRENCHES



D507-10

EXTRA CAPACITY ADJUSTABLE WRENCHES

Forged heat-treated alloy steel.

PART #	HANDLE FINISH	CAPACITY	LENGTH
507-8	Plain chrome	1-1/8"	8-1/8"
507-10	Plain chrome	1-5/16"	10-1/8"
507-12	Plain chrome	1-1/2"	12-1/4"
D507-8	Plastic-dipped	1-1/8"	8-1/4"
D507-10	Plastic-dipped	1-5/16"	10-1/4"
D507-12	Plastic-dipped	1-1/2"	12-3/8"



SELF-LOCKING ADJUSTABLE WRENCH

Slide button mechanism for fast adjustments.

PART #	LENGTH	CAPACITY
AC10NK	10"	1-1/4"



GOAT WRENCH

Serrated jaw grips nuts, bolts or pipe from 1/2" to 1-1/4".

PART #	FINISH	CAPACITY
920	Alloy Steel	1-1/4"



LINEMAN'S "BELL" WRENCHES

Heat treated forged steel. Each end has two size openings.

PART #	LARGE END	SMALL END
3146	29/32" x 13/32"	5/8" x 13/16"
3146A	11/16" x 15/16"	5/8" x 7/8"
3146B	11/16" x 13/16"	11/16" x 7/8"



WISE GRIPS

The original Vise-Grip® locking pliers. High-grade steel alloy.

PART #	LENGTH	CAPACITY
7CR	7"	1-1/2"
10CR	10"	1-7/8"

WRENCHES

Many other sizes available.



ERECTION WRENCHES

Forged steel to withstand high leverage and heavy loads. Tapered handle for lining-up bolt hole. Many other sizes available.

PART #	SIZE	TYPE	LENGTH	WEIGHT
3210	7/8"	US Heavy	14-3/4"	1.36 lbs.
3211	1-1/16"	US Heavy	14-3/4"	1.31 lbs.
3212	1-1/4"	US Heavy	16-5/8"	1.98 lbs.
3213	1-7/16"	US Heavy	17-3/8"	2.72 lbs.
3214	1-5/8"	US Heavy	18"	3.36 lbs.
3219	3/4"	US Regular	14-3/4"	1.36 lbs.
3220	13/16"	US Regular	14-3/4"	1.35 lbs.
3221	1"	US Regular	14-3/4"	1.31 lbs.
3222	1-1/8"	US Regular	16-5/8"	2 lbs.
3223	1-5/16"	US Regular	17-3/8"	2.87 lbs.
3224	1-1/2"	US Regular	18"	3.37 lbs.
3231	15/16"	Utility	14-3/4"	1.31 lbs.
3232	1-1/16"	Utility	16-5/8"	2 lbs.



1/2" DRIVE RATCHETING CONSTRUCTION WRENCH

Forged from select alloy steel with a corrosion resistant black finish.

PART #	DRIVE	LENGTH	WEIGHT
3238	1/2"	15"	2.10 lbs.



ADJUSTABLE HEAD CONSTRUCTION WRENCHES

Forged from select alloy steel with a corrosion resistant black finish.

PART #	CAPACITY	LENGTH	WEIGHT
3227	1-5/16"	11"	1.20 lbs.
3239	1-1/2"	16"	2.36 lbs.

WRENCHES

Many other sizes available.



OPEN END STRAIGHT SPUD WRENCHES

PART #	SIZE	WEIGHT	LENGTH
32-832	1"	1.12 lbs.	14-1/2"
32-834	1-1/16"	1.82 lbs.	17"
32-836	1-1/8"	1.95 lbs.	17"
32-840	1-1/4"	2.36 lbs.	19"
32-842	1-5/16"	2.25 lbs.	19"
32-846	1-7/16"	3.78 lbs.	21"
32-848	1-1/2"	3.84 lbs.	21"
32-852	1-5/8"	4.55 lbs.	23"
32-858	1-13/16"	8.84 lbs.	25"
32-860	1-7/8"	8.41 lbs.	25"
32-864	2"	8.16 lbs.	25"



OFFSET OPEN END SPUD WRENCHES

PART #	SIZE	WEIGHT	LENGTH
32-532	1"	1.36 lbs.	14-1/2"
32-534	1-1/16"	1.90 lbs.	17"
32-536	1-1/8"	1.90 lbs.	17"
32-540	1-1/4"	2.93 lbs.	19"
32-542	1-5/16"	2.55 lbs.	19"
32-546	1-7/16"	4.22 lbs.	21"
32-548	1-1/2"	4.40 lbs.	21"
32-552	1-5/8"	6.76 lbs.	23"
32-558	1-13/16"	8.10 lbs.	25"
32-560	1-7/8"	8.25 lbs.	25"
32-564	2"	8.85 lbs.	25"



12 POINT OFFSET BOX END SPUD WRENCHES

PART #	SIZE	WEIGHT	LENGTH
32-732	1"	1.06 lbs.	13-1/2"
32-734	1-1/16"	1.56 lbs.	14-3/4"
32-736	1-1/8"	1.59 lbs.	14-3/4"
32-740	1-1/4"	2.14 lbs.	17"
32-742	1-5/16"	2.21 lbs.	17"
32-746	1-7/16"	3.36 lbs.	21"
32-748	1-1/2"	3.17 lbs.	21"
32-752	1-5/8"	4.44 lbs.	21"
32-758	1-13/16"	5.82 lbs.	23"
32-760	1-7/8"	5.92 lbs.	23"
32-764	2"	7.20 lbs.	24"

WRENCHES



12 POINT OFFSET STRIKING WRENCH

PART #	SIZE	WEIGHT	LENGTH
1980	2-1/2"	8.56 lbs.	15-1/4"
1982	2-9/16"	8.52 lbs.	15-1/4"
1984	2-5/8"	8.49 lbs.	15-1/4"
1988	2-3/4"	12.10 lbs.	15-1/4"
1992	2-7/8"	12.01 lbs.	16"
1989	2-15/16"	11.53 lbs.	16-1/2"
1996	3"	14.17 lbs.	16-1/2"
1997	3-1/8"	14.87 lbs.	16-1/2"

12 POINT STRAIGHT SLUGGING WRENCH

PART #	SIZE	WEIGHT	LENGTH
1880	2-1/2"	13.67 lbs.	12-11/16"
1882	2-9/16"	13.63 lbs.	13-1/16"
1889	2-3/4"	12.65 lbs.	13-7/16"
1889A	3"	18.52 lbs.	13-13/16"
1890	3-1/8"	18.38 lbs.	13-13/16"
1890A	3-3/8"	18.38 lbs.	14-1/8"
1891	3-1/2"	17.08 lbs.	14-1/8"
1891A	3-3/4"	21.50 lbs.	14-1/2"



COMBINATION RATCHET WRENCHES

PART #	SIZE	WEIGHT	LENGTH
9012	3/8"	.11 lbs.	6.25"
9014	7/16"	.14 lbs.	6.50"
9016	1/2"	.20 lbs.	7.00"
9018	9/16"	.22 lbs.	7.50"
9020	5/8"	.31 lbs.	8.20"
9022	11/16"	.37 lbs.	8.87"
9024	3/4"	.48 lbs.	9.76"
9026	13/16"	.73 lbs.	11.47"
9028	7/8"	.76 lbs.	11.47"
9030	15/16"	1.08 lbs.	13.11"
9032	1"	1.06 lbs.	13.11"
9034	1-1/16"	1.32 lbs.	14.14"
9036	1-1/8"	1.97 lbs.	15.84"

WRENCHES



STEEL TRANSFORMER WRENCH

Stainless steel wrench with a penta socket on one end and 3/4" hex on the other. Folding cross-rod for leverage.

PART #	FINISH
PHW-1	Stainless Steel



PENTA WRENCH

Stainless steel Penta socket mounted on ergonomic handle.

PART #
PW-2



"T" HANDLE PENTA WRENCH

Heavy-duty wrench with T-handle and deep penta socket.

PART #	LENGTH
BW-99	6"



TRI-PENTA WRENCH

A 7-3/4" long T-handle penta wrench. The handle incorporates a 3/8" flat screwdriver and a hand hole lid lifter. The green "Speed Sleeve" lets this wrench spin freely to quickly open & close transformers and switch gear.

PART #	LENGTH
TPW-1	7-3/4"



PENTA BUSTER

Used by hand or with a 1/2" drive ratchet wrench. The razor sharp teeth easily cut through ice, debris and dirt around the penta head. With the teeth retracted, a penta socket is exposed to loosen the bolt.

PART #	DRIVE
TE804-5	1/2"



TWISTOOL

A multifunctional lineman's hand tool that allows for safe work to be done while eliminating arc faults, electrical shocks, and injuries to the user. The Twist Tool can be used to start staples, parking your hand line, spread triplex, install or remove hot arms and ground clamps. The open end can also temporarily insulate a secondary cable simply by inserting the conductor and twisting the tool.

PART #
WITT1

BOX WRENCHES



RATCHETING BOX WRENCHES

Chrome plated, laminated construction for greater strength. Reverse ratchet by turning the wrench over.

PART #	POINT	SIZE	LENGTH	WEIGHT
68200	12	1/4" x 5/16"	4-3/8"	.13 lbs.
68201	12	3/8" x 7/16"	5-1/2"	.18 lbs.
68202	12	1/2" x 9/16"	6-7/8"	.29 lbs.
68203	12	5/8" x 11/16"	8-1/4"	.43 lbs.
68204	12	5/8" x 3/4"	8-1/4"	.42 lbs.
68205	12	11/16" x 3/4"	9-1/4"	.52 lbs.
68206	12	13/16" x 7/8"	9-1/4"	.69 lbs.



68221



68222

RATCHETING BOX WRENCH SETS

Ratcheting box wrenches in vinyl roll-up pouch.

PART #	POINT	DESCRIPTION	SET CONTAINS
68221	12	5-Piece ratcheting box wrench set	68200, 68201, 68202, 68203, 68204
68222	12	7-Piece ratcheting box wrench set	68200, 68201, 68202, 68203, 68204, 68205, 68206

ISOLATED "BUG" WRENCHES

Many other combinations are available.



ISOLATED "BUG" WRENCHES

Made of a high strength and high dielectric polymer, the handles have Indicator Ribs for proper hand placement. These special combination tools allow a line worker to carry one tool that will install hundreds of different connectors.

PART #	END 1 FITTING	END 2 FITTING
BW2212	1/2" Ratchet	9/16" Ratchet
BW2213AR	3/8" Allen ratchet	5/16" Allen ratchet
BW223	3/4" Ratchet	9/16" Ratchet
BW223HD	3/4" Heavy duty ratchet	9/16" Heavy duty ratchet
BW2234	1/2" Ratchet	5/8" Ratchet
BW2237	5/8" Ratchet	3/4" Ratchet
BW224	3/4" Ratchet	7/8" Ratchet
BW240	5/16" Reversible allen ratchet	3/8" Reversible allen ratchet
BW251	90° Penta reversible ratchet	5/16" Reversible allen ratchet
BW244	1/2" & 9/16" Reversible ratchet	5/8" & 3/4" Reversible ratchet
BW288	1/2" & 9/16" Flex head reversible ratchet	5/8" & 3/4" Flex head reversible ratchet
BW400	Fitting to receive Ripley's 4x4 stripper bushings	Eye loop

ISOLATED RATCHET WRENCHES



RBW-91634



RBW-91634WE-S



RBW-91634WE-L



RBW-516RP



RBW-2

ISOLATION RATCHETING SPECIALTY WRENCHES

Designed to provide end to end isolation for maximum safety. Many other combinations available.

These wrenches have ergonomically designed handles with a center window showing the separation of the wrench ends.

PART #	COMBINATIONS
RBW-12916	1/2" Ratchet x 9/16" Ratchet
RBW-91634	9/16" Ratchet x 3/4" Ratchet
RBW-91634WE-S	9/16" Socket x 3/4" Standard socket
RBW-91634WE-L	9/16" Socket x 3/4" Deep socket
RBW-516RP	5/16" Allen x Ratcheting penta
RBW-1	5/16" Allen (one side)
RBW-2	5/16" Allen (both sides)

BOLT-THRU WRENCHES



51T Heavy Duty Cast Handle

151T Stamped Steel Handle

DISTRIBUTION WRENCHES

The unique bolt-thru design allows bolts to pass entirely through the socket or ratchet so that the nuts can be secured on any threaded length. Both handle types have reversible ratchet levers.

PART #	DESCRIPTION	SQUARE SIZES
51D	Heavy duty cast handle with double square socket	1" & 1-1/8" square nuts (5/8" & 3/4" bolts)
51T	Heavy duty cast handle with triple square socket	3/4", 1" & 1-1/8" square nuts (1/2", 5/8" & 3/4" bolts)
151D	Stamped steel handle with double square socket	1" & 1-1/8" square nuts (5/8" & 3/4" bolts)
151T	Stamped steel handle with triple square socket	3/4", 1" & 1-1/8" square nuts (1/2", 5/8" & 3/4" bolts)



Triple square socket 9/16" x 3/4" hex

DUAL END BOLT-THRU RATCHET WRENCHES

Five socket sizes in a single wrench with a triple square socket on one end and a double hex socket on the other. Oversize reversing levers on both ends. Twice as strong as standard ratchet box wrenches.

PART #	LENGTH	WEIGHT
101TDE	9"	2 lbs.
103TDE	12"	2.25 lbs.



Model 152

TRANSMISSION LINE RATCHET WRENCHES

Heavy-duty, lightweight wrenches for larger hardware.

These wrenches come with double square sockets that fit 1-3/8" and 1-1/2" square hardware. Available in two handle styles.

PART #	SIZE	HANDLE	WEIGHT
52	15"	Heavy duty cast	4.25 lbs.
53	20"	Heavy duty cast	5 lbs.
152	17"	Stamped steel	3.5 lbs.

BOLT-THRU RATCHET WRENCHES



LINEMAN'S WRENCH

Bolt-through design allows bolts to pass through the socket. 3/4" x 1" x 1-1/8" combination square socket for most common utility hardware. Bright yellow socket for easy visibility. Works on most common utility pole hardware, such as lag bolts, "C" clamps and suspension bolts. Other socket sizes and combinations available.

PART #	LENGTH	WEIGHT
KT151T	13"	2 lbs.



5-IN-1 LINEMAN'S WRENCH

Bolt-through design allows bolts to pass through the socket. 3/4" and 1" x 1-1/8" combination square socket for most common utility hardware. Bright yellow socket for easy visibility. Works on most common utility pole hardware, such as lag bolts, "C" clamps, and suspension bolts. Offers two popular wrench sizes: 9/16" and 3/4". Other socket sizes and combinations available.

PART #	LENGTH	WEIGHT
KT155T	9-3/8"	1.4 lbs.



HEAVY DUTY 5-IN-1 LINEMAN'S WRENCH

Bolt-through design allows bolts to pass through the socket. 3/4" and 1" x 1-1/8" combination square socket for most common utility hardware. Offers two popular hex sizes: 9/16" and 3/4". Other socket sizes and combinations available.

PART #	LENGTH	WEIGHT
KT155HD	12"	2.1 lbs.

DRIVE RATCHET & TORQUE WRENCHES



RATCHET WRENCH

PART #	DRIVE	LENGTH
4433	1/2"	10-1/4"
5454A	1/2"	16"



FLEX WRENCH

PART #	DRIVE	LENGTH	HANDLE
4437	1/2"	10-5/8"	Knurled



RATCHET TORQUE WRENCHES

PART #	DRIVE	RANGE	LENGTH
57005	3/8"	30-150 In.-lbs.	10-5/8"
57010	1/2"	50-250 ft.-lbs.	24-1/4"



The oversized forward/reverse lever is easy to turn even when the worker is wearing gloves.

INSULATED RATCHET WRENCHES

This 9" insulated wrench provides protection against electrical shock up to 1,000 VAC. It is made of a lightweight, high-impact composite that is as strong as steel.

PART #	DESCRIPTION
TE06IRW-U	3/8" Drive with universal fitting
TE06IRW	3/8" Drive wrench only
TE08IRW-U	1/2" Drive with universal fitting
TE08IRW	1/2" Drive wrench only

1/2" DRIVE SOCKETS

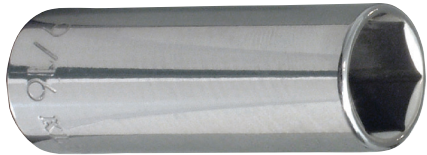

6 POINT DEEP WELL

PART #	SIZE	LENGTH
4516	1/2"	3-3/64"
4518	9/16"	3-3/64"
4520	5/8"	3-3/64"
4522	11/16"	3-3/64"
4524	3/4"	3-3/64"
4526	13/16"	3-3/64"
4528	7/8"	3-3/64"
4530	15/16"	3-3/64"
4532	1"	3-3/64"
4534	1-1/16"	3-3/64"
4536	1-1/8"	3-3/64"
4540	1-1/4"	3-3/64"



6 POINT STANDARD

PART #	SIZE	LENGTH
4016	1/2"	1-7/16"
4018	9/16"	1-7/16"
4020	5/8"	1-15/32"
4022	11/16"	1-15/32"
4024	3/4"	1-15/32"
4026	13/16"	1-9/16"
4028	7/8"	1-5/8"
4030	15/16"	1-5/8"
4032	1"	1-11/16"
4034	1-1/16"	1-3/4"
4036	1-1/8"	1-13/16"
4038	1-3/16"	1-7/8"
4040	1-1/4"	1-59/64"



12 POINT DEEP WELL

PART #	SIZE	LENGTH
4616	1/2"	3-3/64"
4618	9/16"	3-3/64"
4620	5/8"	3-3/64"
4622	11/16"	3-3/64"
4624	3/4"	3-3/64"
4626	13/16"	3-3/64"
4628	7/8"	3-3/64"
4630	15/16"	3-3/64"
4632	1"	3-3/64"
4634	1-1/16"	3-3/64"
4636	1-1/8"	3-3/64"
4638	1-3/16"	3-3/64"
4640	1-1/4"	3-3/64"



12 POINT STANDARD

PART #	SIZE	LENGTH
4116	1/2"	1-7/16"
4118	9/16"	1-7/16"
4120	5/8"	1-15/32"
4122	11/16"	1-15/32"
4124	3/4"	1-15/32"
4126	13/16"	1-9/16"
4128	7/8"	1-5/8"
4130	15/16"	1-5/8"
4132	1"	1-11/16"
4134	1-1/16"	1-3/4"
4136	1-1/8"	1-13/16"
4138	1-3/16"	1-7/8"
4140	1-1/4"	1-59/64"

1/2" DRIVE SOCKETS



410

6 POINT CHROME DEEP WELL SOCKET SETS

PART #	PIECES	SIZES
410	8	1/2", 9/16", 5/8", 11/16", 3/4", 13/16", 7/8", 15/16", 1 rail & 8 clips
414	11	1/2", 9/16", 5/8", 11/16", 3/4", 13/16", 7/8", 15/16", 1", 1-1/16", 1-1/8", 1 rail & 11 clips

6 POINT CHROME STANDARD SOCKET SETS

PART #	PIECES	SIZES
419	14	7/16", 1/2", 9/16", 5/8", 11/16", 3/4", 13/16", 7/8", 15/16", 1", 1-1/16", 1-1/8", 1-3/16", 1-1/4", 2 rails & 14 clips
423	18	3/8", 7/16", 1/2", 9/16", 5/8", 11/16", 3/4", 13/16", 7/8", 15/16", 1", 1-1/16", 1-1/8", 1-3/16", 1-1/4", 10" ratchet, 5" extension, flex handle & metal box



402

12 POINT CHROME DEEP WELL SOCKET SETS

PART #	PIECES	SIZES
409	8	1/2", 9/16", 5/8", 11/16", 3/4", 13/16", 7/8", 15/16", 1 rail & 8 clips
402	11	1/2", 9/16", 5/8", 11/16", 3/4", 13/16", 7/8", 15/16", 1", 1-1/16", 1-1/8", 1 rail & 11 clips



12 POINT CHROME STANDARD SOCKET SET

PART #	PIECES	SIZES
418	12	7/16", 1/2", 9/16", 5/8", 11/16", 3/4", 13/16", 7/8", 15/16", 1", 10" ratchet, 5" extension & metal box

IMPACT SOCKETS - 1/2" DRIVE SPECIAL

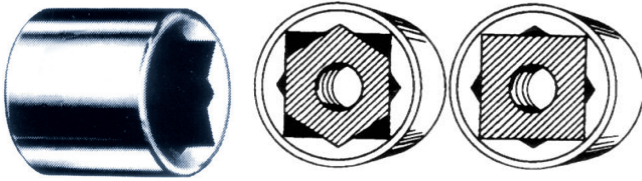

SPECIAL 8 POINT STANDARD

These special 1/2" drive, 8 point sockets are designed for use on both square and hex nuts.

PART #	SIZE	LENGTH
4312	3/8"	1-7/16"
4314	7/16"	1-7/16"
4316	1/2"	1-7/16"
4318	9/16"	1-7/16"
4320	5/8"	1-7/16"
4322	11/16"	1-7/16"
4324	3/4"	1-15/32"
4326	13/16"	1-9/16"
4328	7/8"	1-3/4"
4330	15/16"	1-7/8"
4332	1"	1-15/16"
4334	1-1/16"	1-15/16"
4336	1-1/8"	2"
4340	1-1/4"	2-1/8"

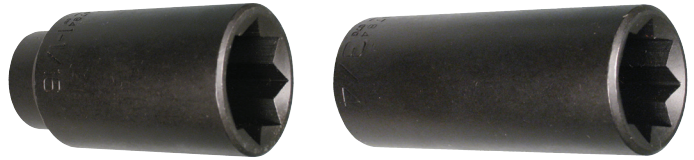

SPECIAL 8 POINT DEEP WELL

"Double Square" sockets are used on 1/2" drive impact wrenches when installing most pole line hardware.

PART #	SIZE	LENGTH
4772	3/8"	3-1/4"
4774	7/16"	3-1/4"
4776	1/2"	3-1/4"
4778	9/16"	3-1/4"
4780	5/8"	3-1/4"
4782	11/16"	3-1/4"
4784	3/4"	3-1/4"
4786	13/16"	3-1/4"
4788	7/8"	3-1/2"
4790	15/16"	3-1/2"
4792	1"	3-1/2"
4794	1-1/16"	3-1/2"
4796	1-1/8"	3-1/2"



See impact wrenches on pages 30-39.



11 PIECE 8 POINT DEEP IMPACT SOCKET SET

1/2" square drive, sizes 1/2" to 1-1/8"

PART #
1311SD

IMPACT SOCKETS - 1/2" DRIVE



6 POINT DEEP WELL

6 POINT STANDARD

12 POINT DEEP WELL

12 POINT STANDARD

PART #	SIZE
2010D	5/16"
2012D	3/8"
2014D	7/16"
2016D	1/2"
2018D	9/16"
2020D	5/8"
2022D	11/16"
2024D	3/4"
2026D	13/16"
2028D	7/8"
2030D	15/16"
2032D	1"
2034D	1-1/16"
2036D	1-1/8"
2038D	1-3/16"
2040D	1-1/4"
2042D	1-5/16"
2044D	1-3/8"
2046D	1-7/16"
2048D	1-1/2"

PART #	SIZE
2010R	5/16"
2012R	3/8"
2014R	7/16"
2016R	1/2"
2018R	9/16"
2020R	5/8"
2022R	11/16"
2024R	3/4"
2026R	13/16"
2028R	7/8"
2030R	15/16"
2032R	1"
2034R	1-1/16"
2036R	1-1/8"
2038R	1-3/16"
2040R	1-1/4"
2042R	1-5/16"
2044R	1-3/8"
2046R	1-7/16"
2048R	1-1/2"

PART #	SIZE
2112D	3/8"
2114D	7/16"
2116D	1/2"
2118D	9/16"
2120D	5/8"
2122D	11/16"
2124D	3/4"
2126D	13/16"
2128D	7/8"
2130D	15/16"
2132D	1"
2134D	1-1/16"
2136D	1-1/8"
2138D	1-3/16"
2140D	1-1/4"
2142D	1-5/16"
2144D	1-3/8"
2146D	1-7/16"
2148D	1-1/2"

PART #	SIZE
2112R	3/8"
2114R	7/16"
2116R	1/2"
2118R	9/16"
2120R	5/8"
2122R	11/16"
2124R	3/4"
2126R	13/16"
2128R	7/8"
2130R	15/16"
2132R	1"
2134R	1-1/16"
2136R	1-1/8"
2138R	1-3/16"
2140R	1-1/4"
2142R	1-5/16"
2144R	1-3/8"
2146R	1-7/16"
2148R	1-1/2"

Sizes up to 2-1/4".

Sizes up to 2-1/4".



13 PIECE 6 POINT DEEP IMPACT SOCKET SET

1/2" square drive, sizes 7/16" to 1-1/4".

PART #
1312D



19 PIECE 12 POINT DEEP IMPACT SOCKET SET

1/2" square drive, sizes 3/8" to 1-1/2".

PART #
1719D

LINEMAN'S PLIERS

WARNING

Plastic dipped handles are NOT intended for protection against electrical shock. For Insulated Hand Tools see page 24.
 Sure-gripping cross-hatched knurled jaws. Hot riveted joint ensures no handle wobble.
 Plastic dipped handles also available with "Journeyman" style soft handles.



HEAVY-DUTY SIDE-CUTTING PLIERS

Cuts ACSR, nails, screws & most hardened wire.

PART #	LENGTH	FEATURES
D2000-9NE	9-3/8"	Standard
HD2000-9NE	9-1/2"	Heavy duty
D2000-9NETH	9-3/8"	5/8" Bolt thread
D2000-9NEGLW	9-3/8"	Hi-visibility



DIAGONAL CUTTING PLIERS

Short jaws and beveled cutting edges permit close cutting of wire, nails, and most hardened wire.

PART #	LENGTH	FEATURES
D228-7	7-1/8"	Standard
D228-8	8-1/16"	Standard
D248-8	8-1/16"	Angled head
D248-8-GLW	8-1/16"	Hi-visibility



JOURNEYMAN™ SIDE-CUTTING PLIERS

PART #	LENGTH	FEATURES
J2000-9NE	9-1/2"	Heavy duty
J2000-9NECR	9-1/2"	Crimping die
J2000-8	8-13/16"	Tapered nose



LONG NOSE PLIERS

PART #	LENGTH	FEATURES
D203-6	6-5/8"	Side cutting jaw
D301-5C	6-5/8"	Spring loaded jaw
D301-6	6-5/8"	Standard jaw
D301-6C	6-5/8"	Spring loaded jaw



HIGH-LEVERAGE SNIP

PART #	LENGTH
24000	6-1/2"



CHANNELLOCK® PLIERS

PART #	LENGTH
420	9-1/2"
430	10"

HAMMERS



HAMMERS

All heads are made of forged, tempered steel.

PART #	DESCRIPTION	HEAD WEIGHT	LENGTH
803-16	Ball-peen	16 oz.	13-1/2"
803-24	Ball-peen	24 oz.	15"
803-32	Ball-peen	32 oz.	15"
808-16	Straight-claw	16 oz.	13"
808-20	Heavy duty hammer with straight-claw	20 oz.	14"
809-36	Lineman's hammer with double-face	36 oz.	14"
809-36MF	Lineman's hammer with milled-face	36 oz.	14"
818-16	Heavy duty hammer with curved-claw	16 oz.	13"
818-20	Heavy duty hammer with curved-claw	20 oz.	14"
832-32	Lineman's hammer with straight-claw	32 oz.	15"
MLH-1	Lineman's hammer with milled-face	35 oz.	13-1/2"



DOUBLE-FACED SLEDGE HAMMERS

Available with wood or fiberglass handles.

PART #	WEIGHT	HANDLE
HIBD-6	6 lbs.	36" Fiberglass
HIBD-8	8 lbs.	36" Fiberglass
HIBD-10	10 lbs.	36" Fiberglass
HIBD-8W	8 lbs.	36" Wood
HIBD-10W	10 lbs.	36" Wood

SCREWDRIVERS & NUT DRIVERS



KEYSTONE TIP - ROUND SHANK

PART #	TIP WIDTH	SHANK LENGTH	OVERALL LENGTH
602-3	7/32"	3"	6-3/4"
602-4	1/4"	4"	8-11/32"
602-6	5/16"	6"	10-15/16"
602-8	3/8"	8"	13-7/16"
602-10	3/8"	10"	15-7/16"
602-12	3/8"	12"	17-7/16"



PHILLIPS TIP - ROUND SHANK

PART #	POINT SIZE	SHANK LENGTH	OVERALL LENGTH
603-1	#2	1-1/2"	3-7/16"
603-3	#1	3"	6-3/4"
603-4	#2	4"	8-5/16"
603-6	#3	6"	11"
603-7	#2	7"	11-5/16"
603-10	#2	10"	14-5/16"



KEYSTONE TIP - SQUARE SHANK

PART #	TIP WIDTH	SHANK LENGTH	OVERALL LENGTH
600-4	1/4"	4"	8-11/32"
600-6	5/16"	6"	10-15/16"
600-8	3/8"	8"	13-7/16"
600-12	1/2"	12"	17-7/16"



CABINET TIP - ROUND SHANK

PART #	TIP WIDTH	SHANK LENGTH	OVERALL LENGTH
605-4	1/4"	4"	8-11/32"
605-6	1/4"	6"	10-15/16"
605-8	1/4"	8"	12-11/32"
605-10	1/4"	10"	14-11/32"



CUSHION GRIP NUT DRIVERS

Chrome-plated, hollow shafts facilitate work on long bolt applications. Cushion Grip handles allow for greater torque and comfort. Handle end is also color coded for easy identification.

PART #	HEX SIZE	SHAFT LENGTH	OVERALL LENGTH
630-3/16	3/16"	3"	6-3/4"
630-1/4	1/4"	3"	6-3/4"
630-5/16	5/16"	3"	6-3/4"
630-11/32	11/32"	3"	6-3/4"
630-3/8	3/8"	3"	6-3/4"
630-7/16	7/16"	3"	7-5/16"
630-1/2	1/2"	3"	7-5/16"
63-9/16	9/16"	4"	9-3/8"
630-5/8	5/8"	4"	9-3/8"
631	7 Piece set sizes: 3/16" through 1/2"		



602-4DD



602-7DD

DEMOLITION SCREWDRIVERS

Engineered, manufactured and tested for prying and chiseling. Plated metal strike cap to protect handle from hammer blows. Heat treated metal shaft runs complete length of handle to strike cap to transfer metal strike force.

PART #	TIP WIDTH	SHANK LENGTH	OVERALL LENGTH
602-4DD	1/4"	4"	9"
602-7DD	5/16"	7"	12-3/8"

MEASUREMENT TOOLS & TOOL SETS

FOLDING RULERS

6' folding rulers. Available in either wood or fiberglass.
Inside read. Graduated to 1/16th".

PART #	MATERIAL
900-6	Wood
910-6	Fiberglass

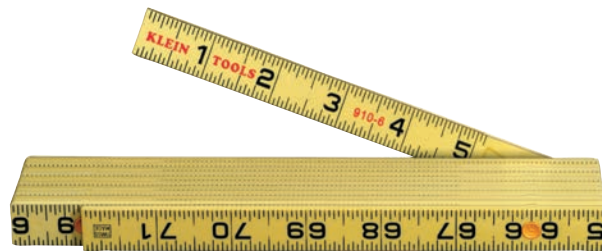

FIBERGLASS TAPES

1/2" woven fiberglass tapes with moisture-proof coating.
Tape line is graduated in feet & inches to 8ths.

PART #	LENGTH	CASE
946-50	50'	Hard case
946-100	100'	Hard case
946-150	150'	Open reel



946-100

946-150

FOLDING HEX-KEY WRENCHES

Squared ends for full-depth fit. Heat-treated alloy steel.

PART #	KEYS	SIZES
70591	9	5/64", 3/32", 7/64", 1/8", 9/64", 5/32", 3/16", 7/32", 1/4"
70583	8	3/32", 7/64", 1/8", 9/64", 5/32", 3/16", 7/32", 1/4"
70581	8	0.050", 1/16", 5/64", 3/32", 7/64", 1/8", 9/64", 5/32"
70579	5	3/16", 7/32", 1/4", 5/16", 3/8"



70591

148 PIECE TOOL KIT

Includes: 1/2, 3/8, 1/4 ratchets, (58) sockets, (18) hex keys
(5) adaptors & extensions, (18) hex keys, (12) combination
wrenches, (2) long nose & diagonal pliers, (4) magnetic
screwdrivers, (1) magnetic bit driver, (44) driver bits,
(1) high impact plastic case.

PART #
CTK148MP



MULTI TOOLS

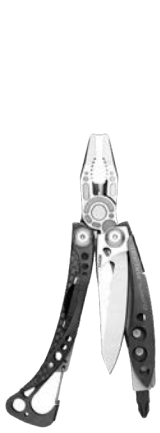

Skeletool



ST 300



Wave



Wingman



Micra



Mut

TOOLS INCLUDED	SKELETOOL	ST 300	WAVE	WINGMAN	MICRA	MUT
Hard-wire cutters	✓	✓	✓			✓
420HC combo knife	✓	✓	✓	✓	✓	✓
Awl with thread loop		✓	✓			
Bit driver (large)	✓		✓	✓		✓
Bottle opener	✓	✓	✓	✓	✓	
Can opener		✓	✓			✓
Diamond-coated file			✓			✓
Electrical crimper		✓				✓
Hammer						✓
Needlenose pliers	✓	✓	✓	✓		✓
Pliers	✓	✓	✓			
Ruler		✓	✓	✓	✓	
Saw		✓	✓			
Screwdriver (large)		✓				
Screwdriver (medium)		✓		✓	✓	
Screwdriver (phillips)		✓		✓	✓	
Screwdriver (small)		✓		✓	✓	
Spring-action scissors			✓	✓	✓	
Stranded-wire cutters		✓				
Wire cutters			✓			✓
Wire stripper	✓	✓	✓	✓		
Wood/metal file		✓	✓	✓		
Bolt override tool						✓
Bronze carbon scraper						✓
#8-32 Cleaning rod/brush adapter						✓
Firearm disassembly punch						✓

LINEMAN'S SKINNING KNIVES

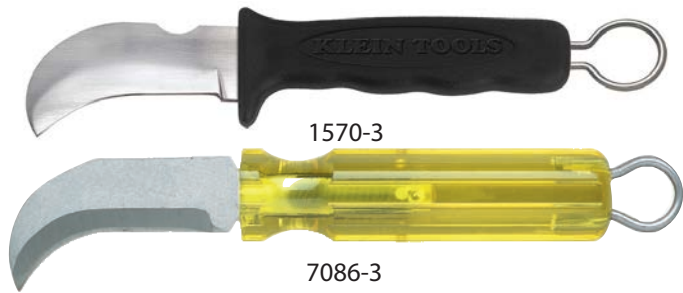

SKINNING KNIVES

Notches on blade backs for scraping & cleaning conductors

PART #	HANDLE
1570-3	Flat handle, notched blade & ring
1570-3LR	Flat handle, notched blade, no ring
7086-1	Round stock handle with no ring
7086-3	Round handle, notched blade & ring
7090-13	Ergonomic handle, notched blade, no ring
7090-3	Ergonomic handle, notched blade & ring
7091G	High-vis, round rubber, no notch, with ring



BB-2



BB-2S

BRUSH BLADE™

Features a blunt-tip blade integrated with a wire brush. The replaceable wire brush cleans conductors up to 1,000 MCM.

PART #	DESCRIPTION
BB-2	Lineman's knife integrated with a wire brush.
BB-2S	Lineman's knife integrated with a wire brush.
WB-1	Replacement wire brush



LINEMAN'S DRAWKNIFE

Safely shaves insulation or semi-con from a wide range of cable sizes without damaging the conductor.

PART #
7095



INSULATED SKINNING KNIFE

Double layer insulation rated to 1,000 VAC.

PART #
IEK20



UNIVERSAL SKINNING KNIFE

Fits on any brand of universal hot stick and has a 3" blade.

PART #
M4455-50

POCKET KNIVES



44001



44001-BLK



44005



44006



44007



44052-BLK



44144



44201



44217



44220



44222



LKN045



SALK-1



SALK-2S



PK-1

POCKET KNIVES

PART #	BLADE LENGTH	DESCRIPTION
44001	2-1/2"	AUS 8 stainless steel blade, silver anodized-aluminum handle and belt clip
44001-BLK	2-1/2"	Drop point AUS 8 stainless steel black chrome blade, black anodized aluminum handle and belt clip
44005	2-5/8"	General purpose knife with AUS 8 stainless steel blade with nylon resin handle
44006	2-5/8"	Lockback knife with AUS 8 stainless-steel sheepfoot blade, silver anodized-aluminum handle
44007	2-1/2"	Lockback knife with AUS 8 stainless steel coping blade, silver anodized-aluminum handle
44052-BLK	2-9/16"	Tanto lockback knife with AUS 8 stainless steel black chrome blade and anodized aluminum handle
44144	3-3/8"	Folding pocket knife with 440A stainless steel drop point blade with aluminum handle
44201	3-3/8"	Electrician's pocket knife with wire stripping notches, 440A stainless steel blade, aluminum handle
44217	3-3/8"	Electrician's pocket knife drop point blade, No. 2 Phillips screwdriver, and three wire stripping notches
44220	3-1/2"	Black drop point 440A stainless steel blade blade and black aluminum handle
44222	3-1/2"	Pocket knife with 440A stainless steel tanto-style blade, Realtree Xtra camouflage handle, lanyard hole
LKN045	2-1/4"	Lockback knife with stainless steel blade and rubberized grip
SALK-1	2-3/4"	Lineman safety knife, one handed opening and closing, safety lock when closed
SALK-2S	2-3/4"	Lineman safety knife, blunt tip area and recessed cutting area, one handed opening & closing
PK-1	2-1/2"	Multi-purpose pocket knife with black oxide stainless steel blade, strap cutter and glass breaker

KNIFE ACCESSORIES

SKINNING KNIFE HOLDER

PART #
4089



CABLE SPLICERS KIT

PART #	ITEM
46037	Cable splicers kit
44200	Splicer's knife
2100-7	Scissors
5187	Leather pouch



TE-SS



TE-PS



QSHARP

SHARPENERS

PART #	DESCRIPTION
TE-SS	Knife sharpener made of MICRO 100 super carbide, it will sharpen anything with a blade
TE-PS	4-In-1 knife sharpener with 4 different edges sharpen and repair all types of blades
QSHARP	Four sharpening angles: 17°, 20°, 25° and 30°, sharpens in 3 to 4 strokes

INSULATED HAND TOOLS

These double-insulated tools are tested at 10,000 VAC and are rated at 1,000 VAC when used on energized parts. They are made in the USA and comply with IEC 900 and ASTM F1505-01 standards.



SIDE-CUTTING PLIERS FOR ACSR

Cuts ACSR, screws, nails & most hardened wire.

PART #	JAW LENGTH	LENGTH
P9SCNE-H	1-9/16"	9"



SIDE-CUTTING PLIERS WITH CRIMPER

Crimper for insulated & non-insulated terminals plus a 12 AWG wire stripping hole.

PART #	JAW LENGTH	LENGTH
P9SCNE-CR	1-1/2"	9"



STANDARD-DUTY SIDE-CUTTING PLIERS

PART #	JAW LENGTH	LENGTH
P7SCNE	1-1/4"	7"
P8SCNE	10-7/16"	8"
P9SCNE	2"	9"

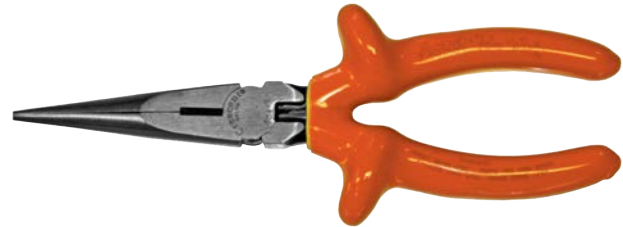

SIDE-CUTTING NEEDLE NOSE PLIERS

PART #	JAW LENGTH	LENGTH
P6CN	10-7/8"	6"
P7CN	2-11/16"	7"
P8CN	2-3/8"	8"



WATER PUMP PLIERS

PART #	JAW OPENING	LENGTH
P8WP	10-1/2"	8"
P10WP	1-1/2"	10"
P12WP	2-1/4"	12"
P16WP	4-1/4"	16"
P20WP	5-1/2"	20"



FULLY INSULATED ADJUSTABLE WRENCH

PART #	JAW OPENING	LENGTH
AW-6FI	15/16"	6"
AW-8FI	1-1/8"	8"
AW-10FI	1-3/8"	10"
AW-12FI	1-1/2"	12"

INSULATED HAND TOOLS

These double-insulated tools are tested at 10,000 VAC and are rated at 1,000 VAC when used on energized parts. They are made in the USA and comply with IEC 900 and ASTM F1505-01 standards.



PHILLIPS-TIP SCREWDRIVERS

PART #	POINT SIZE	SHANK LENGTH
P2-6-CG	#2	6"
P2-8-CG	#2	8"



MECHANICS-TIP SCREWDRIVERS

PART #	TIP WIDTH	SHANK LENGTH
Y6-CG	5/16"	6"
Y8-CG	3/8"	8"
Y10-CG	3/8"	10"



BOLT CUTTERS

PART #	LENGTH	WEIGHT
BC-18-INS	18"	3.5 lbs.
BC-24-INS	24"	5.25 lbs.
BC-30-INS	30"	8.5 lbs.



CABLE CUTTERS

PART #	LENGTH
CC-24-INS	24"
CC-30-INS	30"



RATCHET CABLE CUTTERS

PART #	CAPACITY
RCC500-INS	Cuts 500 MCM Cu / 1-1/4" Al
RCC750-INS	Cuts 750 MCM Cu / 1-3/4" Al



T-HANDLE HEX WRENCH

PART #	HEX KEY	LENGTH
IHK-516	5/16"	6"

INSULATED HAND TOOLS

These double-insulated tools are tested at 10,000 VAC and are rated at 1,000 VAC when used on energized parts. They are made in the USA and comply with IEC 900 and ASTM F1505-01 standards.



STANDARD INSULATED SOCKETS

PART #	SIZE	DRIVE
IS12-12	3/8"	1/2"
IS12-14	7/16"	1/2"
IS12-16	1/2"	1/2"
IS12-18	9/16"	1/2"
IS12-20	5/8"	1/2"
IS12-22	11/16"	1/2"
IS12-24	3/4"	1/2"
IS12-26	13/16"	1/2"
IS12-28	7/8"	1/2"
IS12-30	15/16"	1/2"
IS12-32	1"	1/2"

INSULATED DEEP SOCKETS

PART #	SIZE	DRIVE
IS12-16L	1/2"	1/2"
IS12-18L	9/16"	1/2"
IS12-20L	5/8"	1/2"
IS12-22L	11/16"	1/2"
IS12-24L	3/4"	1/2"
IS12-26L	13/16"	1/2"
IS12-28L	7/8"	1/2"
IS12-30L	15/16"	1/2"
IS12-32L	1"	1/2"



RATCHET WRENCHES

PART #	DESCRIPTION
IR12-LC	1/2" Drive overall length 10-1/4"
IR38-LC	3/8" Drive overall length 5-1/2"



DRIVE EXTENSION

PART #	DRIVE	LENGTH
IB12-5	1/2"	Overall length 5"
IB12-10	1/2"	Overall length 10"



HEX BIT SOCKETS

PART #	SIZE	DRIVE
IH12-10	5/16"	1/2"
IH12-12	3/8"	1/2"
IH12-14	7/16"	1/2"
IH12-16	1/2"	1/2"

ISOLATED SHAFT EXTENSIONS

Made with thick-walled, filament wound fiberglass shafts, these tools provide total end-to-end isolation.



ISOLATED SOCKET EXTENSIONS

1/2" square male & female ends. Rated for 600 in.-lbs. of torque.

PART #	DRIVE/SOCKET	LENGTH	KV RATING
ISE-8	1/2" Square	8"	5kV
ISE-14	1/2" Square	14"	10kV



ISE-4

ISE-WE

ISOLATED HEX SHAFT EXTENSIONS

5/16" hex male shafts. Rated for 600 in.-lbs. of torque.

PART #	DRIVE SIZE	LENGTH	KV RATING
ISE-4	3/8" Square	4-1/2"	1,000V
ISE-WE	1/2" Square	5-1/2"	1,000V

LONG REACH INSULATED CUTTING TOOLS

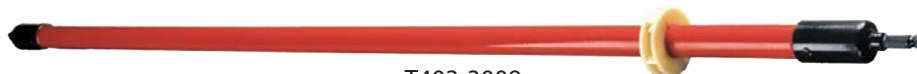

T403-3009



C403-2137

7/16" HEX EXTENSION STICK

Insulated extension stick works with hydraulic power tools on bucket trucks. Its 7/16" hexagonal quick connect fitting couples with a power tool's drive socket. On the other end, its square detent-ball fitting accepts all 1/2" drive wrenches.

FLEXIBLE INSULATED WRENCHES

Standard square socket in lower end accepts 1/2" square-shank ratchet or similar hand tools. Square shank on upper end fits any 1/2" drive socket. Mounted on 1-1/2"-diameter

Epoxiglas® extensions, these wrenches may be used for tightening nuts on hardware fittings on high-voltage lines.

PART #	LENGTH	WEIGHT
T403-3009	4'	5 lbs.

PART #	LENGTH	WEIGHT
C403-2137	6' 3"	5.5 lbs.
C403-2136	8' 3"	6.5 lbs.

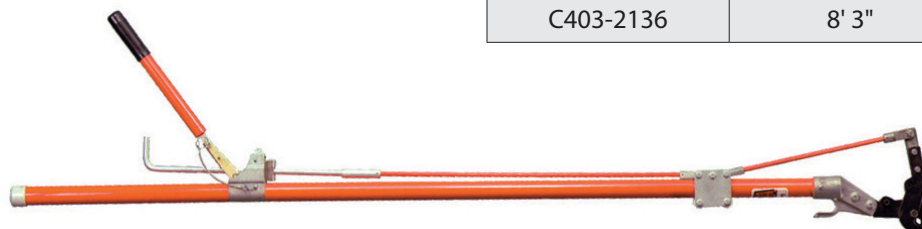

INSULATED RATCHET CABLE CUTTERS

PART #	ACSR	ALUMINUM	COPPER	LENGTH	WEIGHT
C403-1381		1,000 kcmil	500 kcmil	6'	11 lbs.
C403-1382	556 kcmil			6'	11 lbs.
C403-1383		1,000 kcmil	500 kcmil	8'	11.5 lbs.
C403-1384	556 kcmil			8'	11.5 lbs.



INSULATED LEVER TYPE CABLE CUTTERS

PART #	ACSR	COPPER	LENGTH	WEIGHT
H1871-6	1/0	2/0 Solid	6' 6"	6.75 lbs.
H1873-6	4/0	4/0 Stranded	6' 7"	9.75 lbs.
T403-0687	4/0	4/0 Stranded	8' 7"	10.25 lbs.



INSULATED HYDRAULIC CABLE CUTTERS

PART #	ACSR	COPPER / ALUMINUM	LENGTH	WEIGHT
C403-0731	954 MCM	500 MCM	6'	13 lbs.
C403-0732	954 MCM	500 MCM	8'	15 lbs.

SOFT CABLE CUTTERS

WARNING

These tools are NOT considered insulated. Do not attempt to cut energized conductors with any of these cutters.



SOFT CABLE RATCHET CUTTER

PART #	CAPACITY
RC400	400 MCM stranded Cu/Al



SOFT CABLE CUTTER

PART #	CAPACITY
RC750	750 MCM stranded Cu/Al



SOFT CABLE RATCHET CUTTER

PART #	CAPACITY	LENGTH
63711	600 MCM stranded Cu/Al	11-1/2"

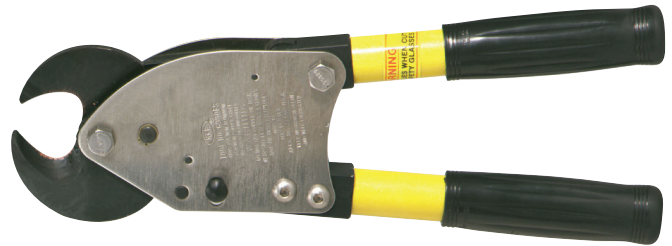

See page 387 for repair parts.

RATCHET CABLE CUTTER

PART #	CAPACITY	LENGTH
6990FS	795 MCM/500 MCM	14"



TE200

See page 399 for repair parts.

PRECISION CABLE CUTTERS

These tools provide cutting ease, minimum cable distortion and long life. The fiberglass handles meet ASTM F711.

PART #	CAPACITY	LENGTH
TE750	750 MCM Cu/Al	20"
TE200	2000 MCM Cu/Al	20"

HAND-HELD ACSR RATCHET CABLE CUTTERS

WARNING

These tools are NOT considered insulated. Do not attempt to cut energized conductors with any of these cutters.



ACSR CUTTER

Cuts up to 400 MCM copper 600 MCM aluminum and 336 MCM ACSR. Weighs 1-1/2 lbs. and is 10-1/4" long.

PART #	CAPACITY
63607	336 single-strand ACSR



ACSR CUTTER

The cutting blades cut up to 350 MCM copper and 500 MCM aluminum. Weighs 1-1/2 lbs. and is 10-1/4" long.

PART #	CAPACITY
TE336	336 single-strand ACSR



ACSR CUTTER

The replaceable cutting blades can easily cut through multi-strand 477 MCM ACSR. It also cuts up to 1-1/4" Cu/Al, 1" solid copper and 1/2" guy wire, not for EHS.

PART #	CAPACITY	WEIGHT	LENGTH
63800	477 MCM ACSR	3.2 lbs.	13-3/4"
63858	Replacement blades	---	---



ACSR CUTTER

Ratchet-action design provides maximum leverage with minimum effort for heavy-duty use. Cuts steel and ACSR. Features forged, heat-treated, shear-type blades and 24" long steel handles with heavy vinyl grips.

PART #	CAPACITY
63700	1113 MCM ACSR



ACSR CUTTER

The fiberglass handles incorporate a fast advance system that quickly close the blades around the wire. See page 400 for repair parts.

PART #	CAPACITY
TE556	556 MCM ACSR

HYDRAULIC IMPACT WRENCHES



HYDRAULIC IMPACT WRENCH

Reverse-flow check valve, built in selector for open center or closed center systems, 7/16" quick change chuck, 7/16" hex to 1/2" square adapter. Flow range: 4-12 GPM.

PART #	TORQUE	WEIGHT
ID07810	500 ft.-lbs.	7 lbs.

HYDRAULIC IMPACT WRENCH

Built-in hydraulic check valve with easy change between open-center and closed-center systems. 7/16" quick-change chuck and 7/16" hex to 1/2" square adapter. Flow range: 4-12 GPM. Variable torque models available.

PART #	TORQUE	WEIGHT
HW1	500 ft.-lbs.	6-1/2 lbs.

HYDRAULIC IMPACT WRENCH

Reversible, twin hammer wrench with a spool selector for open-center or closed-center systems. Features a 7/16" quick-change chuck and 7/16" hex to 1/2" square adapter. Flow range: 4-10 GPM. Variable torque model available.

PART #	TORQUE	WEIGHT
H8508-1	400 ft.-lbs.	7-1/2 lbs.



These hydraulic wrenches are pressure tested and torque certified prior to shipment.

HYDRAULIC IMPACT WRENCH

3/4" square drive and reversible flow rate switch. Flow range: 4-12 GPM.

PART #	TORQUE	WEIGHT
IW12140	250 to 1,200 ft.-lbs.	18 lbs.

HYDRAULIC IMPACT WRENCH

3/4" square drive, open & closed center systems spool selector. Flow range: 4-12 GPM.

PART #	TORQUE	WEIGHT
HW3	1283 ft.-lbs.	10-1/2 lbs.



These hydraulic wrenches are pressure tested and torque certified prior to shipment.

HYDRAULIC IMPACT WRENCH ASSEMBLY

ID07 impact wrench assembled with 8' of non-conductive hydraulic hose and flat face couplers. Ready for field use.

PART #
TEID07810-C



These hydraulic wrenches are pressure tested and torque certified prior to shipment.

HYDRAULIC IMPACT WRENCH ASSEMBLY

H8508-1 impact wrench assembled with 8' of non-conductive hydraulic hose and flat face couplers. Ready for field use.

PART #
TEH8508-C

HYDRAULIC IMPACT WRENCH ACCESSORIES

2,250 PSI hose is used with low pressure hydraulic tools. These hoses can be supplied with or without flat face couplers.



Shown without couplers

LOW-PRESSURE HYDRAULIC HOSE

Red hose is non-conductive.

PART #	DIAMETER	LENGTH	COLOR
TELPNC06-08	3/8"	8'	Red
TELPNC06-10	3/8"	10'	Red



Shown with couplers

LOW-PRESSURE HYDRAULIC HOSE

Black hose is vulcanized, wire-braided reinforced.

PART #	DIAMETER	LENGTH	COLOR
TELPV08-25-MF	1/2"	25'	Black
TELPV08-50-MF	1/2"	50'	Black



FF3716FP

HTMA COUPLER - FEMALE

PART #	CONNECTION
FF3716FP	3/8" Internal thread
FF3718FP	1/2" Internal thread



FF3726FP

HTMA COUPLER - MALE

PART #	CONNECTION
FF3726FP	3/8" Internal thread
FF3728FP	1/2" Internal thread



HTMA COUPLER

PART #	TYPE	CONNECTION
54923	Male	3/4-16 SAE o-ring external thread
54925	Female	3/4-16 SAE o-ring external thread

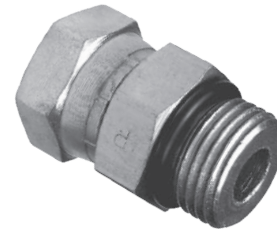

SWIVEL FITTING

PART #	CONNECTION
2066-6-8S	3/8" NPT female to 3/4" x 16" o-ring
03-6900-6-6	3/8" NPT female to 9/16" x 18" o-ring

HYDRAULIC IMPACT WRENCH ACCESSORIES

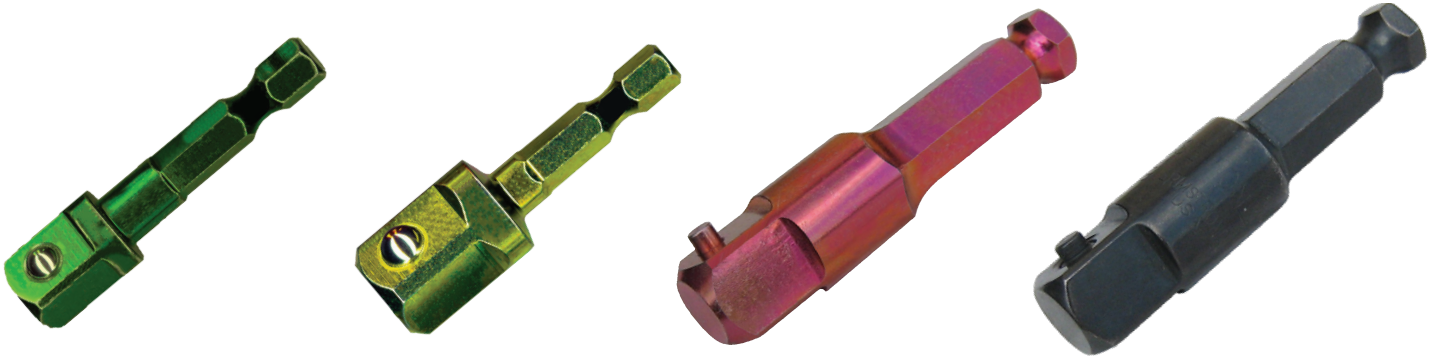

DNIA1438

DNIA1412

DNIA

PRJ7121

QUICK CHANGE IMPACT ADAPTERS

PART #	DESCRIPTION	LENGTH
DNIA1438	1/4" Hex to 3/8" Square	1-7/8"
DNIA1412	1/4" Hex to 1/2" Square	2"
DNIA	7/16" Hex to 1/2" Square	2-3/4"
PRJ7121	7/16" Hex to 1/2" Square	2-3/4"



SQUARE DRIVE TO QUICK CHANGE CHUCK

PART #	SIZE
QR-514	1/2" Square to 7/16" quick change chuck
QR-714	3/4" Square to 7/16" quick change chuck



1/2" - 20 THREADED FEMALE DRIVE TO 7/16" QUICK CHANGE CHUCK

PART #
QRF-14



7/16" HEX TO 1/2" KEYLESS CHUCK

Not designed for reverse impacting.

PART #
TE2530



7/16" TO 1/2" JACOBS CHUCK ADAPTER KIT

Includes chuck key.

PART #
TE2590

BATTERY POWERED IMPACT WRENCHES



M18™ FUEL™ 3/8" COMPACT IMPACT WRENCH WITH FRICTION RING

Kit includes: Compact impact wrench, (2) battery packs, multi-voltage charger, belt clip and carrying case.

PART #	MAX TORQUE	WEIGHT
2754-22	210 ft-lbs.	3.3 lbs.



M18™ FUEL™ 7/16" HEX HIGH TORQUE IMPACT WRENCH KIT

Kit includes: Hex impact drill, (2) battery packs, AC/DC wall & vehicle charger and contractor bag.

PART #	MAX TORQUE	WEIGHT
2765-22	500 ft-lbs.	7.1 lbs.



M18™ FUEL™ 1/2" HIGH TORQUE IMPACT WRENCH WITH PIN DETENT KIT

Kit includes: High torque impact wrench, (2) battery packs, multi-voltage charger and carrying case.

PART #	MAX TORQUE	WEIGHT
2762-22	350 - 600 ft-lbs.	7 lbs.



M18™ FUEL™ 3/4" HIGH-TORQUE IMPACT WRENCH WITH FRICTION RING KIT

Kit includes: Impact wrench with friction ring, (2) battery packs, multi-voltage charger and carrying case.

PART #	MAX TORQUE	WEIGHT
2764-22	375 - 750 ft-lbs.	7.3 lbs.

BATTERY POWERED IMPACT WRENCH ACCESSORIES



48-11-1820



48-11-1850



48-11-1860



48-11-1890

M18™ REDLITHIUM™ BATTERIES

Fully compatible with all M18™ cordless products currently available.

PART #	DESCRIPTION
48-11-1820	2.0 Compact battery pack
48-11-1850	XC5.0 Extended capacity battery pack
48-11-1860	XC6.0 Extended capacity battery pack
48-11-1890	High Demand™ 9.0 battery pack



48-59-1801



48-59-1808

M18™ LITHIUM-ION CHARGERS

PART #	DESCRIPTION	VOLTAGE
48-59-1801	M18™ Battery charger	120 VAC
48-59-1808	M18™ & M12™ Rapid charger	120 VAC
48-59-1812	M18™ & M12™ Multi-voltage charger	120 VAC

BATTERY POWERED IMPACT WRENCHES



20V MAX XR 3/8" COMPACT IMPACT WRENCH KIT

Kit includes: Tool, (2) batteries, charger, tool bag and belt clip.

PART #	MAX TORQUE	WEIGHT
DCF890M2	150 ft.-lbs.	2 lbs.



20V MAX XR HIGH TORQUE 7/16" IMPACT WRENCH WITH QUICK RELEASE CHUCK KIT

Kit includes: Tool, (2) batteries, and a multi-voltage charger.

PART #	MAX TORQUE	WEIGHT
DCF898P2	500 ft.-lbs.	7.2 lbs.



20V MAX XR HIGH TORQUE 1/2" IMPACT WRENCH WITH DETENT PIN ANVIL KIT

Kit includes: Tool, (2) batteries, and a multi-voltage charger.

PART #	MAX TORQUE	WEIGHT
DCF899P2	700 ft.-lbs.	7.2 lbs.



20V MAX XR HIGH TORQUE 3/4" IMPACT WRENCH WITH HOG RING RETENTION PIN ANVIL KIT

Kit includes: Tool, (2) batteries, and a multi-voltage charger.

PART #	MAX TORQUE	WEIGHT
DCF897P2	700 ft.-lbs.	7.2 lbs.

BATTERY POWERED IMPACT WRENCH ACCESSORIES



DCB204



DCB205



DCB206

20V MAX XR LITHIUM-ION BATTERY PACK

PART #	CAPACITY	NICAD / LITHIUM
DCB204	Standard	Lithium-ion
DCB205	5.0Ah	Lithium-ion
DCB206	6.0Ah	Lithium-ion



DCB606



DCB609

20V/60V MAX FLEXVOLT BATTERY PACKS

Compatibility with 20V MAX, 60V MAX, 120V MAX tools and all 20V MAX chargers.

PART #	CAPACITY	NICAD / LITHIUM
DCB606	6.0Ah	Lithium-ion
DCB609	9.0Ah	Lithium-ion



20V MAX FAN COOLED FAST CHARGER

Charges the battery in 90 minutes or less.

PART #	SYSTEM
DCB118	2V - 20V MAX Lithium-ion batteries



20V MAX FAN COOLED FAST CHARGER

Compatible with 20V MAX batteries and the new 20V/60 MAX Flexvolt battery packs.

PART #	SYSTEM
DCB118	60V, 20V MAX Lithium-ion batteries

BATTERY POWERED IMPACT WRENCHES



1/4" CORDLESS IMPACT DRIVER KIT

Kit includes: Brushless impact driver, (2) batteries, rapid charger and tool case.

PART #	MAX TORQUE	WEIGHT
XDT13T	1,500 in.-lbs.	3.3 lbs.



7/16" HEX IMPACT WRENCH KIT

Kit includes: Brushless high torque impact wrench, (2) batteries, rapid charger and tool bag.

PART #	MAX TORQUE	WEIGHT
XWT09T	590 ft.lbs.	8.1 lbs.



3/8" SQUARE DRIVE IMPACT WRENCH KIT WITH FRICTION RING ANVIL

Kit includes: Impact wrench, (2) batteries, rapid optimum charger and tool bag.

PART #	MAX TORQUE	WEIGHT
XWT06	155 ft.lbs.	3.4 lbs.



1/2" SQUARE DRIVE IMPACT WRENCH KIT WITH FRICTION RING ANVIL

Kit includes: Brushless high torque impact wrench, (2) Lithium-ion batteries, rapid charger and tool bag.

PART #	MAX TORQUE	WEIGHT
XWT08T	740 ft. lbs.	7.9 lbs.

BATTERY POWERED IMPACT WRENCHES

Makita's expanding 18V Lithium-ion series is the world's largest cordless tool line-up powered by an 18V Lithium-ion slide-style battery. Makita 18V Lithium-ion batteries have the fastest charge times in their categories, so they spend more time working and less time sitting on the charger.



18V LXT® LITHIUM-ION BATTERIES

Integrated L.E.D. battery charge level indicator allows user to monitor battery charge. Reaches full charge in 45 minutes or less. Compatible only with Makita 18V Lithium-ion tools with Star Symbol™ and/or yellow battery receivers.

PART #	CAPACITY
BL1830B	3.0Ah
BL1840B	4.0Ah
BL1830B	5.0Ah
BL1860B	6.0Ah



18V LXT® LITHIUM-ION RAPID OPTIMUM CHARGER

Charges 18V LXT® 2.0Ah battery in 25 minutes, 3.0Ah in 30 min., 4.0Ah in 40 min., 5.0Ah in 45 min. Built-in fan cools the battery during the charging process for faster charge time.

PART #	VOLTAGE
DC18RC	120 VAC



18V LXT® LITHIUM-ION DUAL PORT RAPID OPTIMUM CHARGER

The new 18V Lithium-ion Dual Port Rapid Optimum Charger charges two batteries simultaneously, giving tool users unparalleled charging efficiency so their batteries spend more time working and less time sitting on the charger.

PART #	VOLTAGE
DC18RD	120 VAC



18V LXT® LITHIUM-ION OPTIMUM AUTOMOTIVE CHARGER

Makita's Rapid Automotive Charger is compatible with 12 VDC sockets found in most autos and trucks, so it goes wherever the job takes you. The DC18SE will charge Makita slide-style Lithium-ion batteries, including the 18V LXT Lithium-ion 3.0Ah and 18V Compact Lithium-ion 2.0Ah batteries.

PART #	VOLTAGE
DC18SE	12 VDC

IMPACT AUGER BITS & HAND BRACE

Specialty drill bits are available for almost any application.



TEFLON COATED IMPACT BITS

Designed for making deep, smooth cuts in utility poles, railroad ties, pressure-treated lumber and wet or frozen wood. Teflon coated carbon steel resists heat and friction.



POWER POLE BITS

These bits feature a 7/16" hex shank with a cutting spur for clean holes. Ideal for use on large poles. Not for use in impacts.

PART #	DIAMETER	TWIST	O.A.L.
TB1809	9/16"	15"	18"
TB1811	11/16"	15"	18"
TB1813	13/16"	15"	18"
TB1815	15/16"	15"	18"
TB1817	1-1/16"	15"	18"
TB2409	9/16"	21"	24"
TB2411	11/16"	21"	24"
TB2413	13/16"	21"	24"
TB2415	15/16"	21"	24"
TB2417	1-1/16"	21"	24"
TB3011	11/16"	21"	30"
TB3013	13/16"	21"	30"
TB3015	15/16"	21"	30"
TB3017	1-1/16"	21"	30"

PART #	DIAMETER	TWIST	O.A.L.
46809	9/16"	12"	17"
46811	11/16"	12"	17"
46813	13/16"	12"	17"
46909	9/16"	18"	23"
46911	11/16"	18"	23"
46913	13/16"	18"	23"
46915	15/16"	18"	23"
47009	9/16"	24"	29"
47011	11/16"	24"	29"
47013	13/16"	24"	29"
47015	15/16"	24"	29"
47017	1-1/16"	24"	29"



HAND BRACE BITS

A cutting spur scribes the outside of the pole during drilling for a smooth, clean hole. The tapered square shank can be removed to fit both hand braces and power drills.

PART #	DIAMETER	TWIST	O.A.L.
46607	7/16"	12"	18"
46609	9/16"	12"	18"
46611	11/16"	12"	18"
46613	13/16"	12"	18"
46615	15/16"	12"	18"
46617	1 1/16"	12"	18"
46711	11/16"	18"	24"
46713	13/16"	18"	24"



HAND BRACE

Features a 12 point reversible ratchet, with a 10" sweep, tough molded head and handle. The 4-jaw format is designed to hold 1/8" to 7/16" shank bits, as well as tapered shanks.

PART #
TEBR10

IMPACT POLE BITS, 7/16" HEX SHANKS

All of these drill bits are available with 5/8" hex shank, small and larger diameters and in lengths up to 48".
Specialty drill bits are available for almost any application.



ELIMINATOR - IMPACT POLE BITS

Bit quickly and cleanly bores through all types of wood. The carbide cutting tip combined with a hardened steel cutting edge that can be re-sharpened.



PENETRATOR - IMPACT POLE BITS

A replaceable carbide tip allows these bits to drill faster than standard bits. These bits are made to accept the high torque generated by hydraulic impact wrenches.

PART #	DIAMETER	TWIST	O.A.L.
ER71509	9/16"	15"	18"
ER71511	11/16"	15"	18"
ER71513	13/16"	15"	18"
ER71515	15/16"	15"	18"
ER71517	1-1/16"	15"	18"
ER72109	9/16"	21"	24"
ER72111	11/16"	21"	24"
ER72113	13/16"	21"	24"
ER72115	15/16"	21"	24"
ER72117	1-1/16"	21"	24"

PART #	DIAMETER	TWIST	O.A.L.
PN71209	9/16"	15"	18"
PN71211	11/16"	15"	18"
PN71213	13/16"	15"	18"
PN71215	15/16"	15"	18"
PN71217	1-1/16"	15"	18"
PN71809	9/16"	21"	24"
PN71811	11/16"	21"	24"
PN71813	13/16"	21"	24"
PN71815	15/16"	21"	24"
PN71817	1-1/16"	21"	24"



FIREBALL - IMPACT POLE BITS

These self-feeding, all purpose pole bits have replaceable, double spur carbide-tips. Unique flute design produces straight, clean holes.



FIBERGLASS POLE IMPACT BITS

Designed specifically for drilling through hollow solid/foam utility poles made of fiberglass, resin or composite materials. The full flute and solid body enables easy drilling.

PART #	DIAMETER	TWIST	O.A.L.
H71209	9/16"	15"	18"
H71211	11/16"	15"	18"
H71213	13/16"	15"	18"
H71215	15/16"	15"	18"
H71217	1-1/16"	15"	18"
H71809	9/16"	21"	24"
H71811	11/16"	21"	24"
H71813	13/16"	21"	24"
H71815	15/16"	21"	24"
H71817	1-1/16"	21"	24"

PART #	DIAMETER	TWIST	O.A.L.
FGS71509	9/16"	15"	18"
FGS71511	11/16"	15"	18"
FGS71513	13/16"	15"	18"
FGS71515	15/16"	15"	18"
FGS72109	9/16"	21"	24"
FGS72111	11/16"	21"	24"
FGS72113	13/16"	21"	24"
FGS72115	15/16"	21"	24"

SPECIALTY SOCKETS & ADAPTERS

NR1 - NUT RUNNER

4-way deep socket has openings on both ends. One end accepts 3/4" square nuts (3/8" bolts) and 13/16" square nuts (1/2" bolts). The other end is sized for 1" square nuts (5/8" bolts) and 1-1/8" square nuts (3/4" bolts). 7/16" hex to 3/4" square adapter included.



PART #	DESCRIPTION	LENGTH
NR1	Nut Runner with adapter	7-3/4"
DNIA-1	Replacement NR1 adapter	3-1/8"

NUT & BOLT SIZES

Nut Size	3/4"	13/16"	1"	1-1/8"
Bolt Size	3/8"	1/2"	5/8"	3/4"

NR2 - NUT RUNNER

3-way socket similar to the NR1 but for larger size hardware. The NR2 accepts 1-1/8" square nuts (3/4" bolts) in one end and 1-5/16" square nuts (7/8" bolts) & 1-1/2" square nuts (1" bolts) on the other. 7/16" hex to 1" square adapter included.

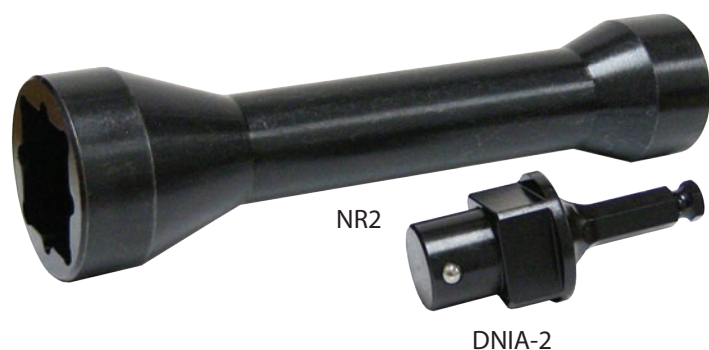

PART #	DESCRIPTION	LENGTH
NR2	Nut Runner with adapter	8-5/8"
DNIA-2	Replacement NR2 adapter	3-1/4"

NUT & BOLT SIZES

Nut Size	1-1/8"	1-5/16"	1-1/2"
Bolt Size	3/4"	7/8"	1"



Shown exposing the 13/16" square for 1/2" hardware.



SINGLE END TRIPLE SQUARE IMPACT SOCKET

Easily change from the 3/4" square to the 1" and 1-1/8" square utilizing the locking slide cam. 7/16" to 1/2" adapter included.

PART #	DESCRIPTION
SETSYS	Triple Socket with adapter
DNIA	Replacement 7/16" to 1/2" adapter

NUT & BOLT SIZES

Nut Size	13/16"	1"	1-1/8"
Bolt Size	1/2"	5/8"	3/4"

SPECIALTY SOCKETS & ADAPTERS



PENTA SOCKET
1/2" square drive.

PART #
R-9076



PENTA DRIVER

This is a 9" long penta socket with a 1/2" square drive. The green "Speed Sleeve" allows this driver to spin freely to quickly open & close transformers and switch gear. 3/8" hex by 1/2" square adapter is included.

PART #
PSD-1



PENTA/HEX SOCKET

Penta Socket on one end and a 3/4" hex socket on the other end with a common 1/2" female drive.

PART #
PHS-2

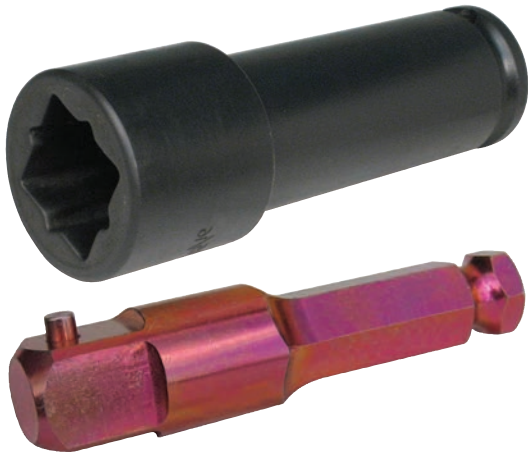

DOUBLE SQUARE IMPACT SOCKET
1/2" square drive, 5" long.

PART #	SIZES
081315S5	13/16" x 15/16"
081618S5	1" x 1-1/8"
DNIA	7/16" hex to 1/2" square



IMPACT HEX DRIVERS

Ideal for meter bases and secondary pedestal connectors. These drivers accept 1/2" drive. Also available in 3/8" drive.

PART #	SHANK	LENGTH
29104F	5/16"	4"
29124F	3/8"	4"
29164F	1/2"	4"
29106F	5/16"	6"
29126F	3/8"	6"
29166F	1/2"	6"

STEEL PUNCHES

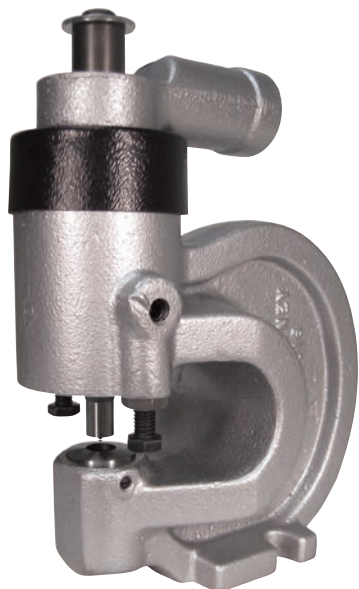

MANUAL HEAVY DUTY STEEL PUNCH

This extremely portable and versatile punch develops 20 tons of force and can cut a 1/2" hole through 1/2" thick mild steel. Supplied with a coupler nut and 1/2" punch & die.

PART #	WEIGHT
20	25 lbs.



PUNCHES & DIES

Type O round punches and dies used in the # 20 punch.

HOLE DIAMETER	PUNCH #	DIE #
1/8"	P02	D02
3/16"	P03	D03
1/4"	P04	D04
5/16"	P05	D05
3/8"	P06	D06
7/16"	P07	D07
1/2"	P08	D08
9/16"	P09	D09
5/8"	P10	D10
11/16"	P11	D11
3/4"	P12	D12
13/16"	P13	D13

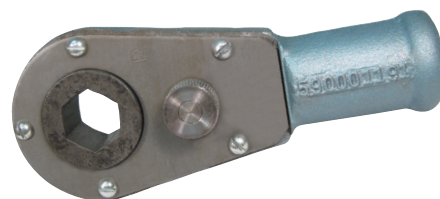

RATCHET ATTACHMENT

For close quarter operation of #20 punch.

PART #
119



CN11 CN12

CN13

COUPLER NUTS

For mounting punches in the #20 punch.

PART #	DESCRIPTION
CN11	For punches up to 11/16"
CN12	Used for the 3/4" punch
CN13	Used for the 13/16" punch



35 TON HYDRAULIC STEEL PUNCH

This portable punch was designed to punch holes through 1/2" mild steel, aluminum and copper. The punched hole size is 1/16" larger than your bolt size. The SH-370M comes complete with four sets of punch and die sizes for 3/8", 1/2", 5/8" and 3/4" bolts.

PART #	WEIGHT
SH-370M	28 lbs.



ROUND PUNCHES & DIES FOR SH-370M

PART #	DESCRIPTION	BOLT SIZE
SHD-18	1/8" Punch & die set	
SHD-316	3/16" Punch & die set	
SHD-14	1/4" Punch & die set	
SHD-516	5/16" Punch & die set	
SHD-38	3/8" Punch & die set	
SHD-716	7/16" Punch & die set 10.5	3/8"
SHD-12	1/2" Punch & die set	
SHD-916	9/16" Punch & die set 13.5	1/2"
SHD-58	5/8" Punch & die set	
SHD-1116	11/16" Punch & die set 17.5	5/8"
SHD-34	3/4" Punch & die set	
SHD-1316	13/16" Punch & die set 20.5	3/4"

MAGNETIC STEEL DRILLS



LINEMAN'S MAGNETIC DRILL KIT

Delivers the strongest magnetic hold on 1/4" steel, and drills over (40) 13/16" holes per charge. Features a magnet base that delivers up to 2,000 lbs. of holding force, 2 speed gear box: 400/690 RPM and 1-1/2" annular cutter capacity. Kit includes: drill, (2) 9.0Ah batteries, magnetic oil reservoir, (2) pilot pins, 1/2" chuck adapter, charger and case.

PART #	ARBOR BORE	HEIGHT	WIDTH	LENGTH	WEIGHT
2788-22HD	3/4"	15-1/2"	7-1/2"	13-3/4"	29.5 lbs.



Shown without safety guards

MAGNETIC DRILL

Cutting oil is applied by an automatic, through spindle cooling system. The magnet dead lift is 1,810 lbs. on a 1" plate. Powered by a 120V, 1.6 HP motor.

PART #
06920



Shown without safety guards

MAGNETIC DRILL

The magnet dead lift on this drill is 1,480 lbs. on a 1" plate. This drill has a 120V, 1.75 HP motor. The coolant is automatically applied to the cutting area.

PART #
USA101

MAGNETIC DRILL SPECIFICATIONS

PART #	MAX DEPTH	MAX DIAMETER	ARBOR BORE	MAGNET BASE	HEIGHT	WEIGHT
06920	2"	1-5/8"	3/4"	4" x 6-1/2"	11-3/8"	27 lbs.
USA101	2"	1-1/2"	3/4"	3" x 6-1/4"	17-5/8"	28 lbs.

MAGNETIC STEEL DRILL ACCESSORIES



1" DEEP CUTTERS

High speed steel with 3/4" shank.

PART #	DIAMETER
S4375	7/16"
S5000	1/2"
S5625	9/16"
S6250	5/8"
S6875	11/16"
S7500	3/4"
S8125	13/16"
S8750	7/8"
S9375	15/16"
S1000	1"
S1062	1-1/16"
S1125	1-1/8"
S1187	1-3/16"
S1250	1-1/4"
S1312	1-5/16"
S1375	1-3/8"
S1437	1-7/16"
S1500	1-1/2"
S1562	1-9/16"
S1625	1-5/8"

SHORT CUTTERS

3/4" depth of cut.

PART #	DIAMETER
SJ5000	1/2"
SJ5625	9/16"
SJ6250	5/8"
SJ6875	11/16"
SJ7500	3/4"
SJ8125	13/16"
SJ8750	7/8"
SJ9375	15/16"
SJ1000	1"
SJ1062	1-1/16"

3/4" SHANK ADAPTER

Required to use short cutters.

PART #
AA3412

SHORT CUTTER PILOT PIN

PART #
16046

2" DEEP CUTTERS

High speed steel with 3/4" shank.

PART #	DIAMETER
SL437	7/16"
SL500	1/2"
SL562	9/16"
SL625	5/8"
SL687	11/16"
SL750	3/4"
SL812	13/16"
SL875	7/8"
SL937	15/16"
SL100	1"
SL106	1-1/16"
SL112	1-1/8"
SL119	1-3/16"
SL125	1-1/4"
SL131	1-5/16"
SL137	1-3/8"
SL143	1-7/16"
SL150	1-1/2"
SL156	1-9/16"
SL162	1-5/8"



1" CUTTER PILOT PINS

PART #	CUTTER DIAMETER
16001	1/2" & smaller
16003	9/16" & larger

CUTTING OIL

PART #
10207W

2" CUTTER PILOT PINS

PART #	CUTTER DIAMETER
16002	1/2" & smaller
16004	9/16" & larger

GAS POWERED ENGINE DRILLS

See pages 390 - 397 for repair parts.



EDR-210



EDR-260

HIGH PERFORMANCE ENGINE DRILLS

These high performance drills are extremely rugged and dependable. Both models are reversible and feature electronic ignition and a rear handle support bracket. The all-position diaphragm carburetor allows for operation at any angle.

The EDR-210 has a 1/2" keyed chuck while the EDR-260 has a keyless chuck.

PART #	ENGINE	MAX RPM	WEIGHT
EDR-210	21.2 cc	450	10 lbs.
EDR-260	25.4 cc	650	10.7 lbs.



1/2" - 20 THREADED FEMALE DRIVE TO 7/16" QUICK CHANGE CHUCK

PART #
QRF-14



SQUARE DRIVE TO QUICK CHANGE CHUCK

PART #	SIZE
QR-514	1/2" Square to 7/16" quick change chuck
QR-714	3/4" Square to 7/16" quick change chuck



2-CYCLE OIL

PART #	DESCRIPTION
6450001	1-Gallon mix, 2.6 oz. bottle
6450002	2-Gallon mix, 5.2 oz. bottle

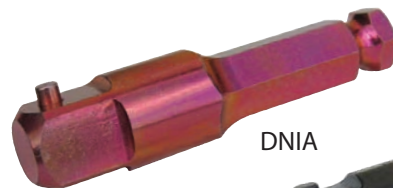

DNIA



PRJ7121

7/16" HEX TO 1/2" SQUARE DRIVE ADAPTERS

PART #	TORQUE CAPACITY	LENGTH
DNIA	500 ft.-lbs.	2-3/4"
PRJ7121	500 ft.-lbs.	2-3/4"

BATTERY POWERED HAMMER DRILLS



M18™ FUEL™ 1/2" DRILL/DRIVER KIT

Kit includes: Drill/Driver,
(2) battery packs, multi-voltage charger,
belt clip, bit holder, side handle and carrying case.

PART #	TORQUE	RPM	WEIGHT
2703-22	1,200 in.-lbs.	2,000	4.9 lbs.



M18™ FUEL™ 1/2" HAMMER DRILL/DRIVER KIT

Kit includes: Drill/Driver,
(2) battery packs, multi-voltage charger,
belt clip, bit holder, side handle and carrying case.

PART #	TORQUE	BPM	WEIGHT
2704-22	1,200 in.-lbs.	32,000	5.0 lbs.



M18™ FUEL™ 1" SDS PLUS D-HANDLE ROTARY HAMMER KIT

Kit includes: D-handle rotary hammer, (2) battery packs, rapid charger, depth rod, side handle and carrying case.

PART #	BLOW ENERGY	BPM	WEIGHT
2713-22HD	2.1 ft.-lbs.	4,400 BPM	7.65 lbs.

M18™ FUEL™ 1" SDS PLUS ROTARY HAMMER KIT

Kit includes: Rotary hammer, (2) battery packs, rapid charger, depth rod, side handle, and carrying case.

PART #	BLOW ENERGY	BPM	WEIGHT
2712-22HD	1.7 ft-lbs.	4,900	8.5 lbs.



M18™ FUEL™ 1-1/8" SDS PLUS ROTARY HAMMER KIT

Kit includes: Rotary hammer, multi-voltage charger, (2) battery packs, depth rod, side handle and carrying case.

PART #	BLOW ENERGY	BPM	WEIGHT
2715-22HD	3.3 ft-lbs.	5,000	7.7 lbs.



M18™ FUEL™ 1-9/16" SDS MAX HAMMER DRILL KIT

Kit includes: Rotary hammer, (2) battery packs, rapid charger, depth rod, side handle, and carrying case.

PART #	BLOW ENERGY	BPM	WEIGHT
2717-22HD	5.1 ft-lbs.	3,000	12.15 lbs.



BATTERY POWERED HAMMER DRILLS & DRIVERS



48-11-1820



48-11-1850



48-11-1860



48-11-1890

M18™ REDLITHIUM™ BATTERIES

Fully compatible with all M18™ cordless products currently available.

PART #	DESCRIPTION
48-11-1820	2.0 Compact battery pack
48-11-1850	XC5.0 Extended capacity battery pack
48-11-1860	XC6.0 Extended capacity battery pack
48-11-1890	High demand™ 9.0 battery pack



48-59-1801



48-59-1808



48-59-1812

M18™ LITHIUM-ION CHARGERS

PART #	DESCRIPTION	VOLTAGE
48-59-1801	M18™ battery charger	120 VAC
48-59-1808	M18™ & M12™ rapid charger	120 VAC
48-59-1810	M18™ & M12™ vehicle charger	120 VAC



20V MAX XR LITHIUM-ION BRUSHLESS 3-SPEED DRILL/DRIVER KIT

Kit includes: Drill/Driver, charger, (2) batteries, belt hook, side handle and kit box.

PART #	CHUCK SIZE	CHUCK TYPE
DCD991P2	1/2"	Metal ratcheting



20V MAX XR LITHIUM-ION BRUSHLESS 3-SPEED HAMMERDRILL KIT

Kit includes: Hammerdrill, charger, (2) batteries, side handle, belt hook and kit box.

PART #	CHUCK SIZE	CHUCK TYPE
DCD996P2	1/2"	Metal ratcheting

BATTERY POWERED HAMMER DRILL & DRIVERS



DCB204



DCB205



DCB206

20V MAX XR LITHIUM-ION BATTERY PACK

PART #	CAPACITY	NICAD / LITHIUM
DCB204	Standard	Lithium-ion
DCB205	5.0Ah	Lithium-ion
DCB206	6.0Ah	Lithium-ion



DCB204BT



DCB205BT

20V MAX BATTERY PACKS WITH BLUETOOTH

Works with ToolConnect™ app to provide additional controls and alerts.

PART #	CAPACITY	NICAD / LITHIUM-ION
DCB204BT	4.0Ah	Lithium-ion
DCB205BT	5.0Ah	Lithium-ion



DCB606



DCB609

20V/60V MAX FLEXVOLT BATTERY PACKS

20V MAX, 60V MAX and 120V MAX compatibility.
Compatible with all 20V MAX chargers.

PART #	CAPACITY	NICAD / LITHIUM
DCB606	6.0Ah	Lithium-ion
DCB609	9.0Ah	Lithium-ion



20V MAX FAN COOLED FAST CHARGER

Compatible with 20V MAX batteries
and the new 20V/60 MAX Flexvolt battery packs.

PART #	SYSTEM
DCB118	60V, 20V MAX

BATTERY POWERED HAMMER DRILL & DRIVERS

Makita's expanding 18V Lithium-ion series is the world's largest cordless tool line-up powered by an 18V Lithium-ion slide-style battery. Makita 18V Lithium-ion batteries have the fastest charge times in their categories, so they spend more time working and less time sitting on the charger.



1/2" HAMMER DRIVER-DRILL KIT

Kit includes: Hammer Driver-Drill, (2) batteries, rapid charger, side handle, depth gauge, belt clip and tool case.

PART #	MAX TORQUE	BPM	WEIGHT
XPH07TB	1,090 in.-lbs.	31,500	5.9 lbs.



1/2" DRIVER-DRILL KIT

Kit includes: Driver-Drill, rapid charger, batteries, side handle, depth gauge, belt clip and tool case.

PART #	MAX TORQUE	WEIGHT
XFD07T	1,090 in.-lbs.	5.8 lbs.



1/2" COMPACT DRIVER-DRILL KIT

Kit includes: Driver-Drill, (2) batteries, rapid charger and tool case.

PART #	MAX TORQUE	WEIGHT
XFD12T	530 in.-lbs.	3.9 lbs.



18V LXT® LITHIUM-ION BATTERY AND CHARGER STARTER PACK

18V LXT® Lithium-ion 5.0Ah battery reaches a full charge in 45 minutes or less. Integrated LED battery charge level indicator allows user to monitor battery charge.

PART #
BL1850BDC1

BATTERY POWERED HAMMER DRILL & DRIVERS

Makita's expanding 18V Lithium-ion series is the world's largest cordless tool line-up powered by an 18V Lithium-ion slide-style battery. Makita 18V Lithium-ion batteries have the fastest charge times in their categories, so they spend more time working and less time sitting on the charger.



18V LXT® LITHIUM-ION BATTERIES

Integrated LED battery charge level indicator allows user to monitor battery charge. Reaches full charge in 45 minutes or less. Compatible only with Makita 18V Lithium-ion tools with Star Symbol™ and/or yellow battery receivers.

PART #	CAPACITY
BL1830B	3.0Ah
BL1840B	4.0Ah
BL1830B	5.0Ah
BL1860B	6.0Ah



18V LXT® LITHIUM-ION RAPID OPTIMUM CHARGER

Charges 18V LXT® 2.0Ah battery in 25 minutes, 3.0Ah in 30 minutes, 4.0Ah in 40 minutes, 5.0Ah in 45 minutes. Built-in fan cools the battery during the charging for faster charge time.

PART #	VOLTAGE
DC18RC	120 VAC



18V LXT® LITHIUM-ION DUAL PORT RAPID OPTIMUM CHARGER

The new 18V lithium-ion dual port rapid optimum charger charges two batteries simultaneously, giving tool users unparalleled charging efficiency so their batteries spend more time working and less time sitting on the charger.

PART #	VOLTAGE
DC18RD	120 VAC



18V LXT® LITHIUM-ION OPTIMUM AUTOMOTIVE CHARGER

Makita's rapid automotive charger is compatible with 12 VDC sockets found in most autos and trucks, so it goes wherever the job takes you. The DC18SE will charge Makita slide-style Lithium-ion batteries, including the 18V LXT Lithium-ion 3.0Ah and 18V Compact Lithium-ion 2.0Ah batteries.

PART #	VOLTAGE
DC18SE	12 VDC

CORDLESS SAWS



18V LXT® METAL CUTTING SAW KIT

Kit includes: Metal cutting saw, (2) batteries, rapid charger, 5-7/8" 32T C.T. saw blade and tool bag.

PART #	BLADE SIZE	CUT DEPTH	WEIGHT
XSC02T	5-7/8"	2-1/4"	6.4 lbs.



18V LXT® CORDLESS RECIPRO SAW KIT

Kit includes: Brushless recipro saw, (2) batteries, rapid charger, recipro saw blade and tool case.

PART #	SPM	STROKE	WEIGHT
XRJ05T	2,300 - 3,000	1-1/4"	8.2 lbs.



M18™ FUEL™ METAL CUTTING CIRCULAR SAW KIT

Kit includes: Metal cutting circular saw, (2) battery packs, multi-voltage charger, 5-3/8" 30T blade, allen wrench and contractor bag.

PART #	BLADE SIZE	CUT DEPTH	WEIGHT
2782-22	5-7/8"	2-1/4"	6.55 lbs.



M18™ FUEL™ RECIPROCATING SAW KIT

Kit includes: Sawzall reciprocating saw, multi-voltage charger, (2) battery packs, blade and carrying case.

PART #	SPM	STROKE	WEIGHT
2720-22HD	0-3,000	1-1/8"	8.9 lbs.



GAS POWERED DRIVER

Lightweight and portable only weighs 32 lbs. Delivers 1720 BPM and can drive 1,000 plus posts on a gallon of gas. Access tough areas that air drivers cannot. Honda GX35 4-cycle engine. Order ground rod sleeves separately.

PART #	DESCRIPTION
RD-2	Gas powered driver
GRS58	5/8" Ground rod sleeve
GRS34	3/4" Ground rod sleeve
GRS3458	5/8" & 3/4" Ground rod sleeve



120 VOLT AC-DC DEMOLITION HAMMER

Features a 15.0Ah motor that accepts 1-1/8" collared hex shank attachments. Provides 61 foot-pounds of impact energy, active vibration control with loaded speed up to 900 BPM. Includes two auxiliary handles & steel case. Weighs 68 lbs.

PART #	DESCRIPTION
D25980	Demolition hammer
D259803	2-Wheel dolly for D25980



120 VOLT DEMOLITION HAMMER

14.0Ah motor accepts 3/4" hex shank attachments. Provides 19.9 foot-pounds of impact energy, no load BPM up to 1,950 and vibration isolation system. Includes two auxiliary handles & steel case. Weighs 27.75 lbs.

PART #
5337-21

HYDRAULIC BREAKERS & DRIVERS

See page 59 for steel attachments. See pages 60 - 61 for couplers, hoses & power units.



These hydraulic tools are pressure tested prior to shipment.

HYDRAULIC DIGGER

This compact tool is ideal for digging in heavy clay and light shale. It easily breaks through frozen ground and dry, hard dirt and comes complete with whip hoses and flush-face, and quick disconnect couplers. Accepts 7/8" x 3-1/4" hex shank attachments and produces up to 1,800 BPM. Flow rate 7-9 GPM with an operating pressure of 1,500 - 2,000 PSI. Weighs 24 lbs. Overall length 20"

PART #
DR19111

HYDRAULIC GROUND ROD DRIVER

A cast-in lifting eye allows the driver to be suspended above the rod and the long side handles give the operator optimal control. All hammering is against an internal socket anvil that fits over the rod preventing it from "mushrooming". Comes complete with 8' whip hoses, in-line on/off valve, flush-face and quick disconnect couplers. Flow rate 5 - 9 GPM, operating pressure 1,500 - 2,000 PSI. Weighs 52 lbs. Overall length 25"

PART #	GROUND ROD SIZE
GD50132RF	1/2" & 5/8"
GD50133RF	3/4" & 1"

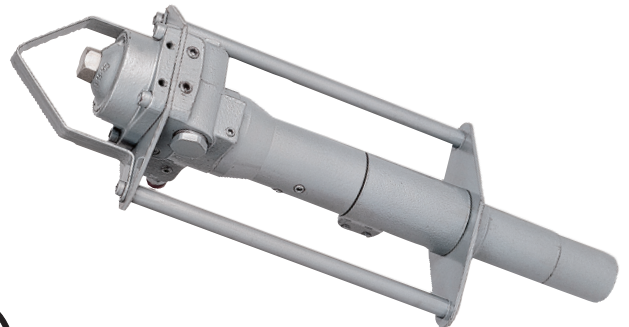

These hydraulic tools are pressure tested prior to shipment.

HYDRAULIC BREAKER

For light to medium duty jobs. The cushioned D-handle and an assist handle allow for operation in both vertical and horizontal positions. Accepts 7/8" x 3-1/4" hex shank attachments. Flow rate 3 - 7 GPM, open-center hydraulic system that produces 1,800 BPM at 5 GPM with an operating pressure 1,250 - 1,850 PSI. Includes 12" whip hoses with 3/8" NPTF ends. Weighs 25 lbs. Overall length 22"

PART #
HPB25

HYDRAULIC GROUND ROD DRIVERS

Dual guide rods provide excellent control for driving rods straight, and the remote on/off valve makes it easy to control the depth of the rod. Flow rate 5 - 8 GPM, open and closed-center hydraulic system that produces 1,740 BPM at 8 GPM. Includes 70" hose with 3/8" NPTF ends, maximum input pressure 2,000 PSI. Power unit weighs 53 lbs. with hose & valve.

PART #	SIZE
HRD-58	5/8"
HRD-1	1"

HYDRAULIC BREAKERS

See page 59 for steel attachments. See pages 60 - 61 for couplers, hoses & power units.



BR67120



This hydraulic tool is pressure tested prior to shipment.

HYDRAULIC BREAKERS

For scoring and cutting concrete, small rock breaking, rod driving and tamping. Hydraulic breakers have a lower noise level than pneumatic breakers and emit no exhaust. All models operate on pressures from 1,500 to 2,000 PSI and come with whip hoses and flush-face, quick disconnect couplers.

PART #	SHANK SIZE	FLOW RATE	WEIGHT	LENGTH
BR45550	1" x 4-1/4"	4 - 6 GPM	51 lbs.	25"
BR45120	1-1/8" x 6"	7 - 9 GPM	51 lbs.	25"
BR67120	1-1/8" x 6"	7 - 9 GPM	67 lbs.	27"
BR87120	1-1/8" x 6"	7 - 9 GPM	83 lbs.	29"



This hydraulic tool is pressure tested prior to shipment.

HYDRAULIC BREAKER

Ideal for breaking sidewalks and curbs and other demolition jobs, these breakers run on open-center hydraulic systems. High blow energy provides maximum breaking power yet these breakers have low noise and vibration levels. 12" whip hoses with 1/2" NPTF ends are included. These breakers are equipped with cushioned, spring-dampened handles that reduce the vibration transmitted to the operator by 80%-90%.

HPB45 models provide 2,160 BPM

HPB55 model delivers 1,860 BPM

Couplers sold separately

PART #	SHANK SIZE	FLOW RATE	WEIGHT	LENGTH
HPB45-1AVS	1-1/8" x 6"	5 - 8 GPM	53 lbs.	28-1/2"
HPB45-2AVS	1" x 4-1/4"	5 - 8 GPM	46 lbs.	26-1/2"
HPB55-1AVS	1-1/8" x 6"	5 - 8 GPM	55 lbs.	30"



HPB45-1AVS

HYDRAULIC BREAKER ATTACHMENTS

Used in small chipping hammers for light-duty jobs as well as heavy-duty breakers for the demolition and cutting of concrete and stone, these tools are made of heat-treated steel to stand up to the most demanding applications. Other attachments are available.

MOIL POINT

LENGTH (under collar)	SHANK SIZE & PART #			
	3/4"	7/8" x 3-1/4"	1" x 4-1/4"	1-1/8" x 6"
12"	48-62-3000	--	--	--
14"	--	A11014	A21014	A31014
18"	48-62-3005	A11018	A21018	A31018



NARROW CHISEL

LENGTH (Under Collar)	SHANK SIZE & PART #			
	3/4"	7/8" x 3-1/4"	1" X 4-1/4"	1-1/8" X 6"
12"	48-62-3010	--	--	--
14"	--	A12014	A22014	A32014
18"	48-62-3015	A12018	A22018	A32018



3" CHISEL

LENGTH (Under Collar)	SHANK SIZE & PART #			
	3/4"	7/8" x 3-1/4"	1" x 4-1/4"	1-1/8" x 6"
12"	48-62-3030	--	--	--
14"	--	A13014	A23014	A33014
18"	--	A13018	A23018	A33018



CLAY SPADE

BLADE WIDTH	SHANK SIZE & PART #			
	3/4"	7/8" x 3-1/4"	1" x 4-1/4"	1-1/8" x 6"
4-1/2"	48-62-3040	B10200	B20200	B30200
5-1/2"	--	B10300	B20300	B30300



GROUND ROD DRIVER

ROD SIZE	SHANK SIZE & PART #			
	3/4"	7/8" x 3-1/4"	1" x 4-1/4"	1-1/8" x 6"
5/8"	48-62-3070	B12783	B22783	B32783
3/4"	48-62-3070	B12785	B22785	B32785
7/8"	--	--	B22787	B32787
1"	--	--	B22789	B32789



ASPHALT CUTTER

BLADE WIDTH	SHANK SIZE & PART #			
	3/4"	7/8" x 3-1/4"	1" x 4-1/4"	1-1/8" x 6"
5"	48-62-3090	B10500	B20500	B30500



HYDRAULIC HOSES & COUPLERS

2,250 PSI hose is used with low pressure hydraulic tools. These hoses can be supplied with or without flat face couplers.



Shown without couplers

LOW-PRESSURE HYDRAULIC HOSE

Red hose is non-conductive.

PART #	DIAMETER	LENGTH	COLOR
TELPNC06-08	3/8"	8'	Red
TELPNC06-10	3/8"	10'	Red



Shown with couplers

LOW-PRESSURE HYDRAULIC HOSE

Black hose is vulcanized, wire-braided reinforced.

PART #	DIAMETER	LENGTH	COLOR
TELPV08-25-MF	1/2"	25'	Black
TELPV08-50-MF	1/2"	50'	Black



FF3716FP

HTMA COUPLER - FEMALE

PART #	CONNECTION
FF3716FP	3/8" Internal thread
FF3718FP	1/2" Internal thread



FF3726FP

HTMA COUPLER - MALE

PART #	CONNECTION
FF3726FP	3/8" Internal thread
FF3728FP	1/2" Internal thread



HTMA COUPLER

PART #	TYPE	CONNECTION
54923	Male	3/4-16 SAE o-ring external thread
54925	Female	3/4-16 SAE o-ring external thread

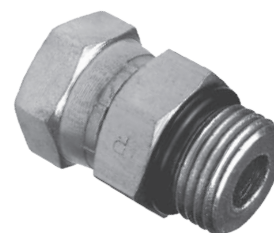

SWIVEL FITTING

PART #	CONNECTION
2066-6-8S	3/8" NPT female to 3/4" x 16" o-ring
03-6900-6-6	3/8" NPT female to 9/16" x 18" o-ring

LOW-PRESSURE HYDRAULIC POWER UNITS



HYDRAULIC POWER UNIT

It's portable, lightweight and quiet. It comes standard with an 18 HP Briggs & Stratton engine. With an open-center system, this pump runs most low pressure tools.

PART #	FLOW RATE	PRESSURE	WEIGHT
GT18B02	5 or 8 GPM	2,000 PSI	330 lbs.



HYDRAULIC POWER UNIT

The 13 HP 4-stroke Honda engine has an easy-pull recoil start. Supplied with quick-release telescoping handles and low-oil alert and shutdown system. Open center system.

PART #	FLOW RATE	PRESSURE	WEIGHT
F13	5 or 8 GPM	2,000 PSI	168 lbs.



HYDRAULIC POWER UNIT

This twin circuit hydraulic power unit can operate two tools at 5 or 8 GPM simultaneously. Each of the two open center circuits is optimized to deliver ideal flows and pressures to both Type 1 and Type 2 hydraulic tools.

PART #	FLOW RATE	PRESSURE	WEIGHT
HP28B02	5 or 8 GPM	2,000 PSI	360 lbs.



HYDRAULIC POWER UNIT

This hydraulic power unit is optimized to deliver open center flows and pressures to both Type 2 and Type 3 hydraulic tools. Its powerful 23 HP Briggs & Stratton engine delivers the power to keep tools working uninterrupted all day.

PART #	FLOW RATE	PRESSURE	WEIGHT
GT23B02	8 or 12 GPM	2,000 PSI	340 lbs.

HYDRAULIC FLOW VALVES & INTENSIFIERS



HYDRAULIC INTENSIFIER

Increases the pressure of the hydraulic system of a vehicle so that high-pressure tools can be operated without an additional power unit. It operates on either open or closed center systems and has an optimum operating pressure of 1,800 PSI at 6 GPM. Flow range is 4 - 7 GPM. Includes a 10' non-conductive, low-pressure twin-line hose and 8' of high-pressure hose.

PART #

TEHIS-810



HYDRAULIC FLOW CONTROL VALVE

Used to control the direction of the flow to the tools, forward or reverse. Includes couplers.

PART #

49913



PVA0021

HYDRAULIC FLOW CONTROL VALVE

4-way, 3-position valves can be connected directly to the tool or used remotely with hoses. Output side couplers included.

PART #

PVA0021

DESCRIPTION

For single acting tools

PVA0022

For double acting tools



HYDRAULIC INTENSIFIER

Works on both open and closed center systems and produces 10,000 PSI. Input pressure is from 1,000 to 2,000 PSI and has a flow rate between 4 - 8 GPM. Couplers & hose sold separately.

PART #

HB10



HYDRAULIC FLOW CONTROL VALVE

Operates off of a vehicle's hydraulic circuit. It can accept a flow of up to 30 GPM and reduce it to a maximum of 10 GPM allowing the correct flow to the hydraulic tool.

PART #

HFC30



HYDRAULIC FLOW & PRESSURE GAUGE

Used to test the hydraulic circuitry by measuring the back pressure, resistance and flow. Includes couplers.

PART #

04182

UTILITY STAPLERS



ST315i



ST400i

CORDLESS UTILITY STAPLERS

Cordless Utility Staplers are just as powerful as the pneumatic staplers but are not reliant on compressors and hoses.

PART #	STAPLE GAUGE	MAGAZINE CAPACITY	BATTERY CAPACITY	FUEL CELL CAPACITY	WEIGHT
ST315i	10-1/2 Gauge	80 staples	3,000 staples per charge	1,000 staples per cell	6.5 lbs.
ST400i	9 Gauge	50 staples	3,000 staples per charge	500 staples per cell	9.5 lbs.



ST315



ST400

PNEUMATIC UTILITY STAPLERS

Engineered specifically for driving heavy-duty staples. Lightweight and corrosion resistant for extreme durability.

PART #	STAPLE GAUGE	OPERATING PRESSURE	WEIGHT
ST315	10-1/2 Gauge	90-120 PSI	6.5 lbs.
ST400	9 Gauge	90-120 PSI	8.5 lbs.

UTILITY STAPLER ACCESSORIES

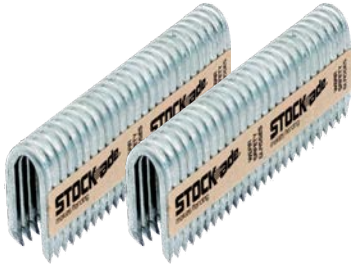

ST315i CONTRACTOR'S PACK

Includes 2,000 1-1/2" 10-1/2 gauge staples and two fuel cells.

PART #	DESCRIPTION
ST315i-CP112	ST315i Contractor pack



ST400i CONTRACTOR'S PACK

Includes 1,000 1-1/2" 9 gauge barbed staples and two fuel cells.

PART #	DESCRIPTION
ST400i-CP112	ST400i Contractor pack



ST315 & ST315i ACCESSORIES

PART #	DESCRIPTION	BOX QTY.
A12535	1-1/2" x 10-1/2 gauge staples	2,100
A12900	ST315i Fuel cell	1
A12910	ST315i Battery	1
905555	ST315i Charger	1



ST400 & ST400i ACCESSORIES

PART #	DESCRIPTION	BOX QTY.
ST159	1-1/2" x 9 gauge staples	1,375
ST1759	1-3/4" x 9 gauge staples	1,200
ST29	2" x 9 gauge staples	1,000
SS4iFUEL	ST400i Fuel cell	1
ST4iBAT	ST400i Battery	1
ST4iCNA	ST400i Charger	1



STAPLE REMOVER

Ideal for repairs and maintenance. Tool includes staple pulling, wire cutting and wire hand tensioning functions.

PART #
STMATE



STAPLE STORAGE CASE

Water tight case for staple storage.

PART #
STCASE

TREE SADDLES

TREE SADDLE SIZING CHART

Fit is important to comfort. Be sure to allow for wear over heavy clothing. In order to obtain an optimum fit, the work positioning D-rings should be positioned slightly forward of the hip bones. Below are typical fits given according to waist size.

SIZE		WAIST SIZE
X-Small	=	24" - 28"
Small	=	28" - 32"
Medium	=	32" - 36"
Large	=	36" - 40"
X-large	=	40" - 44"

Many other tree saddles available.



1871 ECONOMY ERGOVATION® SADDLE

Seat comprised of lightweight foam.

Wide leg straps help distribute pressure on the users' legs snap hooks. Web loops stitched to the suspension strap seat for those who prefer carabiners, eliminating cross loading.

PART #
1871

1877 ECONOMY ERGOVATION® SADDLE

Small dee rings on the bridge prevent shifting and possibility of gate loading carabiners. Leg pads are the same profile as the original Ergovation® Tree Saddle. Leg straps help distribute pressure on the users' legs.

PART #
1877



BUCK ERGOLITE SADDLE

Stainless-steel clevises at either end of a high-strength warp speed bridge. Front buckle closure (for easier on/off wearing spikes). A comfortable, lightweight, and breathable waist belt. Quick-adjust strapping.

PART #
17906

BUCKCAT LIGHTWEIGHT SADDLE

Full adjustability at the sides, waist and legs to obtain a custom fit. Ability to change the length of suspension bridge with a bridge adjustment strap. 7" wide back pad and 4" wide leg pads with 3/4" foam for conformity and comfort.

PART #
16905W1

TREE CLIMBERS



81429R



SB95059

STEEL TREE CLIMBER

Steel contoured tree climber set with ring style straight stirrup, permanent gaffs, nylon straps & leather pads.

PART #	DESCRIPTION
81429R	Nylon leg straps (2239), nylon foot straps (21391), climber pads (3122), standard length sleeves (9204)
SB95059	Nylon leg straps (2239), nylon foot straps (21391), climber pads (3122)

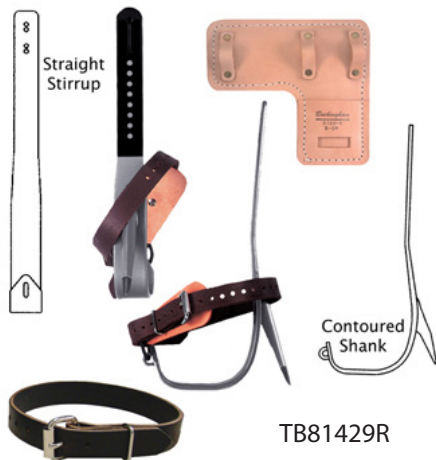

TB81429R



TB95059

TITANIUM TREE CLIMBER

Steel contoured tree climber set with ring style straight stirrup, permanent gaffs, nylon straps & leather pads.

PART #	DESCRIPTION
TB81429R	Nylon leg straps (2239), nylon foot straps (21391), climber pads (3122)
TB95059	Nylon leg straps (2239), nylon foot straps (21391), climber pads (3122), standard length sleeves (9204)



9306

TB9306

NB9306

REPLACEABLE TREE GAFFS

PART #	DESCRIPTION
9306	Pin style for use with model (9309) straight tree climber and (9509) offset
TB9306	Screw style replaceable tree gaffs for all titanium & steel tree climbers
NB9306	Replaceable dowel and screw tree gaff for titanium & steel tree climbers

TREE CLIMBERS & CLIMBER ACCESSORIES



GAFF GUARDS

PART #	DESCRIPTION
60093	Leather gaff guard with bungee strap that attaches to the sleeve loop
60094	Leather gaff guard that fits all manufactures replaceable or permanent pole gaff climbers
6909TA	Snap-on coated wire tree gaff guard made to fit all Buckingham replaceable tree gaff climbers
6909TU	Universal coated wire pole gaff guard made to fit all Buckingham, Bashlin, and Klein tree climbers



9202



9204



996



9215



A9215

CLIMBER SLEEVES

Chrome colored sleeves for standard length climbers.

PART #	DESCRIPTION
9202	Long sleeve, adjust from 19-1/4" to 21-3/4"
9204	Short sleeve, adjust from 14-1/4" to 17-1/4"
A9204	Buckyard sleeve, adjust from 14-1/4" to 17-1/4"

CLIMBER SLEEVE FASTENERS

PART #	DESCRIPTION
996	Climbers with threaded sleeve attachment holes
9215	Climbers with smooth sleeve attachment holes
A9215	BuckAlloy™ aluminum climber sleeves



CLIMBER SHIELD

A lightweight shield that helps to prevent gaff puncture wounds. Ideal for apprentices. Attaches easily to the climber shank with one screw and has a slot to accommodate the climber foot strap.

PART #
10



6306

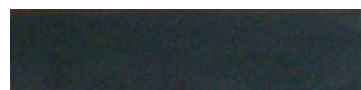

6026



6501

TREE GAFF MAINTENANCE

PART #	DESCRIPTION
6026	Maintenance kit
6306	Tree gaff gauge
6501	Gaff finishing hone

CLIMBERS PADS



BIG BUCK CLIMBER PAD

Utilizes a double strap system, that fits 1" and 1-1/4" straps. Angled metal insert and the thick felt padding adds to the overall comfort. Comes with 2 pair of 2639 straps.

PART #
3118



CLIMBER PAD LEG PROTECTOR

The hook and loop leg protector mounts directly to the leg and underneath a standard climber pad. Provides an additional 1/4" of padding to protect the calf from the climber shank. One size fits all. 10" H x 8-1/2" W.

PART #
3119



T - CLIMBER PAD

The "T" pad has a thick felt liner and a tunnel design to stabilize the climber shank. All leather construction with 3/4" padding.

PART #
3124



L - CLIMBER PAD

A slightly heavier pad that features a closed cell foam filler that prevents the climber shank from irritating the user's leg. Rolled edges prevent chafing. Requires a 26" strap.

PART #
3126

CLIMBER PAD

An angled aluminum 'C' pad for the BuckAlloy™ climbers provide a thicker, over sized felt liner for additional comfort while the liner edge prevents chafing on the leg. Insert prevents the climber shank from shifting on the calf.

PART #	DESCRIPTION
350321	"C" pad
35032KL	Klein compatible "C" pad

*Metal insert for Klein compatible pad is a gold color.



CLIMBER PADS



CUSHION WRAP PADS

PART #	DESCRIPTION	WIDTH	PADDING
3500	Hook and loop pad	4"	3/4"
3500C	Hook and loop pad with cinch loop	4"	3/4"
3503	Hook and loop pad that features a continuous wrap	3"	3/4"
3503C	Hook and loop pad that features a cinch loop	3"	3/4"



CUSHION WRAP PAD WITH STEEL INSERT

PART #	DESCRIPTION	WIDTH	PADDING
3502C	Angled style hook and loop pad that features a cinch loop	4"	3/4"
3502KL	Angled style hook and loop pad that features continuous wrap. Klein compatible	4"	3/4"
3504	A straight style hook and loop pad that features a continuous wrap	3"	3/4"
3504C	A straight style hook and loop pad that features a continuous wrap with a cinch loop	3"	3/4"
3504CKL	Straight style hook and loop pad that features a cinch loop. Klein compatible	4"	3/4"



BIG BUCK WRAP PAD

Features hook and loop wrap pad, the increased surface area of the Big Buck™ pad and a moisture wicking Dri-lex lining.

PART #	DESCRIPTION
3202C	Steel "C-Pad" insert for proper climber shank position. Cinch loop to provide an extra tight fit
32021	for BuckAlloy™ aluminum climbers, steel "C-pad" insert, no cinch loop
32021C	for BuckAlloy™ aluminum climbers, steel "C-pad" insert, cinch loop

TREE LANYARDS



ADJUSTABLE 6' ROPE LANYARD

1/2" 3-strand nylon rope adjustable length, 1706 locking snap hooks both ends, 6 ft. long.

PART #

7VV226



ADJUSTABLE WEB LANYARD

1" wide polyester web, adjustable length, 1706 locking snap hook on both ends, 4 ft. long.

PART #

7VV126



FLIPLINE

A 6' adjustable strand stitched polyester flipline in XTC green with red core features a 5004B LAD (Length Adjusting Device) that allows for easier adjustment to the length of the lanyard with one hand.

PART #

9V08K16M4



PRUSIK LANYARD

3 strand twist nylon rope lanyard with 16 strand 1/2" braided blue streak rope. Carabiner sold separately.

PART #

7VV2A110J



FRICTION SAVER

Benefits include less bend radius, less friction (easier to climb), and reduced wear to rope. Can be used as a false crotch.

Rated for human support only.

PART #	OVERALL LENGTH
57-24	2'
57-36	3'
57-48	4'
57-60	5'
57-72	6'



SPLIT TAIL

Used to tie the friction hitch to the climbing line eliminating the need to cut worn ends from the climbing line. Also used for a dual anchor point climbing system.

PART #	DESCRIPTION
38STB	1/2" blue rope / 4' bluestreak split tail
38STG	1/2" green rope / 4' XTC spearmint split tail
38STO	1/2" orange rope / 4' safety blue high-vee split tail
38STW	1/2" white rope / 4' safety blue split tail
38STY	1/2" yellow rope / 4' goldstreak

CARABINERS



5005



5005M



5005NA



5555S3



5005NIA



5555SA



5005SAE



5005T



5555WSA



5555S1

CARABINERS

PART #	LENGTH	GATE OPENING	BREAKING STRENGTH	STANDARDS MET
5005	4-7/8"	15/16"	9,218 lbs.	ANSI Z359.12
5005M	4-1/2"	1-1/8"	11,240 lbs.	Non man rated
5005NA	4-1/2"	1-3/16"	5,000 lbs.	Not for human support or fall protection
5005NIA	4"	3/4"	5,172 lbs.	Not for human support or fall protection
5555S3	4-7/8"	3/4"	6,744 lbs.	ANSI Z359.12
5005SAE	5-1/4"	3/4"	5,620 lbs.	ANSI Z359.12
5005T	4-3/8"	3/4"	9,216 lbs.	CSA Z259.12 / ANSI Z359.12
5555SA	4-5/8"	1"	6,295 lbs.	
5555S1	4-1/4"	.86"	6,295 lbs.	
5555WSA	4-1/2"	1"	5,625 lbs.	



MICRO PULLEY

Eliminates the need to advance the friction hitch while climbing. 2 in 1 safety prusik lanyard it gives the user easy adjustability with one hand.

PART #
RP110



BLOCK & TACKLE

Used with a Buck Port-A-Wrap III. It comes in 50 feet of 1/2" 16 strand blue streak rope. Rated to 500 lbs. with a working load limit of 2,250 lbs. at 5:1.

PART #
601BT



BUCK BULLY ALUMINUM SWIVEL PLATE PULLEY

For 5/8" rigging line. Minimum breaking strength is 10,000 lbs.

PART #
5007B1



ALUMINUM FIGURE 8

For 5/8" rigging line. Minimum breaking strength is 8,500 lbs.

PART #
5009



RIGGING BLOCK

Aluminum rigging block with a spring loaded upper pin and captive bushing. Safe working load 6,600 lbs.

PART #
5007L



ALUMINUM FIGURE 8 WITH EARS

For 5/8" rigging line. Minimum breaking strength is 8,500 lbs.

PART #
5009E



LOCKING SPREADER SNAP

Locking Spreader Snap 5/8" openings, 9-3/4" length. Rated to 5,000 lbs.

PART #
3032L



LAD

The length altering device that fits on the flipline for quick length adjustment. The 90° cam eliminates the need of a locking twist clevis.

PART #
5004B

RIGGING EQUIPMENT

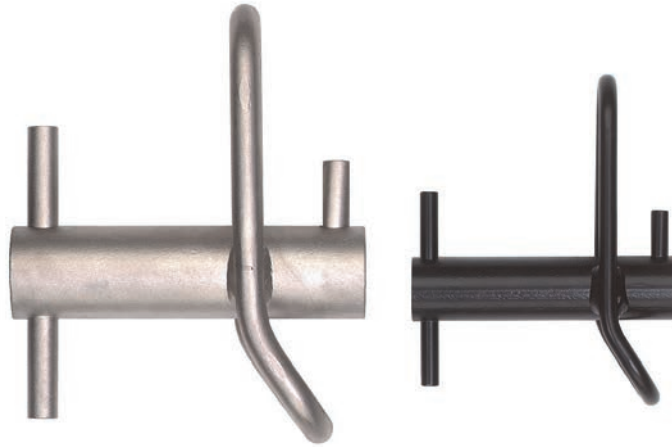

PORT-A-WRAPS

Friction lowering devices that are attached to the base of the tree to provide consistent friction when lowering limbs to the ground. These "rope retention bars" greatly reduce the possibility of losing a wrap in the event the rope goes slack.

PART #	ROPE SIZE	MATERIAL	WEIGHT
601M	1/2"	Steel	1.5 lbs.
601MN	1/2"	Steel / Nickel plated	1.5 lbs.
601	9/16"	Steel	4 lbs.
601N	9/16"	Steel / Nickel plated	4 lbs.
601L	3/4"	Steel	7.25 lbs.
601LN	3/4"	Steel / Nickel plated	7.25 lbs.



THROWBAGS

Available in weights from 8 to 20 ounces and in a variety of colors.

They can also be supplied with pre-cut lengths of 1/8" slickline. Specify weight of throwbag, color and length of rope when ordering. Available rope lengths: 100', 150', 200' & 250'. Available colors: Blue, Green, Leather, Orange, Hot Pink & Red.

PART #	WEIGHT	COLOR
16-14R	14 oz.	Red
16-16R	16 oz.	Red
16-14G	14 oz.	Green
16-16G	16 oz.	Green

TREE TRIMMING



SB-5U



SB-2



SBL-2



A10016

UNIVERSAL PRUNING SAW

The scabbard is made of leather for safe storage of saw.

Adapts to all tools with universal heads and can be used as a hand saw by attaching handle accessory.

PART #	DESCRIPTION	WEIGHT
SB-5U	Universal pruning saw	.6 lbs.
SB-2	Replacement blade	.3 lbs.
SBL-2	Saw scabbard	1 lbs.
A10016	Handle	.5 lbs.



HS-16TE



HS-16SL



SB-8TE-F



WP-8708

HAND SAWS & PRUNING TOOLS

PART #	DESCRIPTION
HS-16TE	Hand saw with 16" tri-edge blade for quick cutting
HS-16SL	Leather scabbard for the HS-16TE hand saw
SB-8TE-F	Folding hand saw with 8" tri-edge blade
WP-8708	Folding pruning tool saw with 8" steel blade, comfort poly grip with safety lock

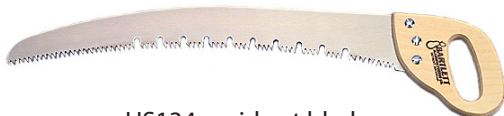

HS134 rapid cut blade



HS137 standard cut blade

HAND SAW

The HS134 model has deep gullets for making large cuts without binding.

Both styles have polished blades with raked teeth, 5 points per inch, which can be easily re-sharpened.

PART #	BLADE LENGTH	BLADE TYPE	LEATHER SCABBARD PART#
HS134-26	26"	Rapid cut	111-27
HS137-24	24"	Standard cut	111-25
HS137-26	26"	Standard cut	111-27



WP-2140



WP-2145

BYPASS & ANVIL LOOPERS

2" capacity with 20" hardwood handles.

PART #	DESCRIPTION
WP-2140	Bypass lopper with a compound action lever which multiplies the handle force to the cutting blades
WP-2145	Anvil lopper with compound action lever design for easy cutting

TREE TRIMMING

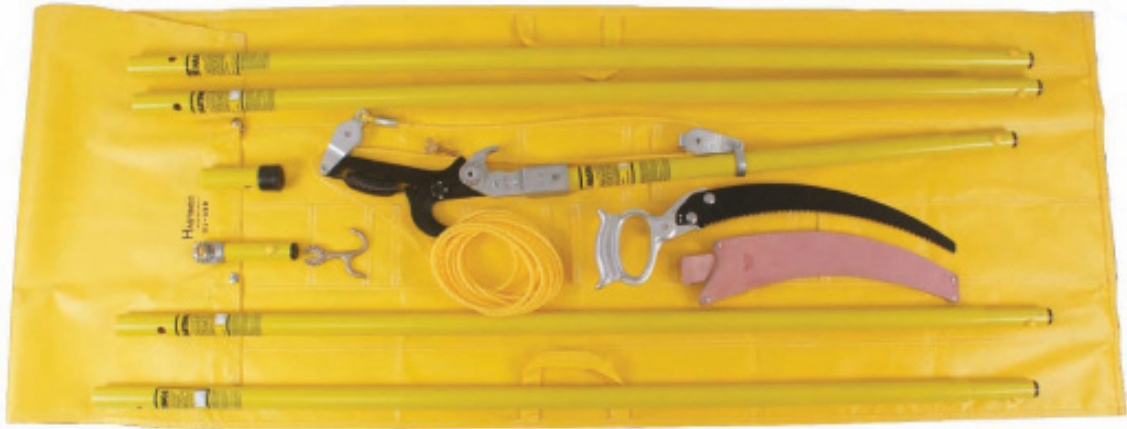

4141

TREE TRIMMING KIT

Open the tool kit bag and you have your choice of tree trimming tools in the length you need, all in a convenient heavy duty vinyl tool bag that offers long wear and maximum protection for the tools. Kits are available with round or square pole sections in four or six foot lengths. Each kit contains the following items:

- 1 Pruner head assembly - 2'
- 4 Extension sections with 1 base cap
- 1 Universal pruning saw (A11000)
- 1 Saw handle (A10016)
- 1 Saw scabbard (A30007)
- 1 Universal adapter (A10012)
- 1 Universal "S" hook
- 1 Multiple pocket vinyl tool bag

ROUND POLES 1-1/4" DIAMETER

PART #	SECTION LENGTH	WEIGHT
4141	4'	15 lbs.
4142	6'	19 lbs.

SQUARE POLES 1-1/4" DIAMETER

PART #	SECTION LENGTH	WEIGHT
4143	4'	15 lbs.
4144	6'	19 lbs.



UNIVERSAL PRUNER

Heavy duty pruner designed for professional arborist with 1-1/4" cutting capacity. 20' rope included.

PART #
P-14-UA



BIG MOUTH PRUNER

This pruner has a 1-3/4" hook opening, the largest cutting capacity in the market. 20' rope included.

PART #
P-34-UA

TREE TRIMMING

Tree trimming equipment for the professional tree trimmer. Two styles available - 1-1/4" O.D. round and 1-1/4" square fiberglass poles. Cutter heads are machined from tool steel and have a 1-1/2" diameter cutting capability. All cutter heads have a splined universal attachment for a pruning saw. Double pulleys give the operator a 3:1 mechanical advantage.



SECTIONAL TREE TRIMMERS - ROUND POLES

CUTTER HEAD			EXTENSION		BASE	
LENGTH	PART #	WEIGHT	PART #	WEIGHT	PART #	WEIGHT
1'	4200	2.0 lbs.	----	----	----	----
2'	4125	3.2 lbs.	----	----	----	----
4'	4201	3.9 lbs.	546-4	1.4 lbs.	552-4	1.5 lbs.
6'	4202	4.6 lbs.	546-6	2.1 lbs.	552-6	2.0 lbs.
8'	4203	5.4 lbs.	546-8	2.8 lbs.	552-8	2.7 lbs.
10'	4204	6.1 lbs.	546-10	3.2 lbs.	552-10	3.5 lbs.

SECTIONAL TREE TRIMMERS - SQUARE POLES

CUTTER HEAD			EXTENSION		BASE	
LENGTH	PART #	WEIGHT	PART #	WEIGHT	PART #	WEIGHT
1'	4210	2.0 lbs.	----	----	----	----
2'	4211	2.4 lbs.	----	----	----	----
4'	4212	3.2 lbs.	4104	1.5 lbs.	4104-2	1.6 lbs.
6'	4213	3.9 lbs.	4106	2.2 lbs.	4106-2	2.3 lbs.
8'	4214	4.7 lbs.	4108	3.0 lbs.	4108-2	3.1 lbs.

POLE PRUNING SAW WITH ADAPTERS

1-1/4" ROUND POLES		1-1/4" SQUARE POLES	
PART #	WEIGHT	PART #	WEIGHT
4056	1.75 lbs.	4040	1.5 lbs.

UNIVERSAL ADAPTERS

ROUND POLES		SQUARE POLES	
PART #	WEIGHT	PART #	WEIGHT
A10012	.4 lbs.	A10031	.5 lbs.

SINGLE POLE TREE TRIMMERS

ROUND POLES 1-1/4" DIAMETER		
LENGTH	PART #	WEIGHT
10'	4117	5.0 lbs.
12'	4119	6.0 lbs.
14'	4121	6.5 lbs.
16'	4123	7.0 lbs.

SQUARE POLES 1-1/4" DIAMETER		
LENGTH	PART #	WEIGHT
10'	4150	5.0 lbs.
12'	4151	5.5 lbs.
14'	4152	6.5 lbs.
16'	4153	7.0 lbs.

TREE TRIMMING



UNIVERSAL TREE PRUNER

Complete unit mounted on 12" fiberglass shaft with universal adapter and 25' rope.

PART #	WEIGHT
10-019	3.0 lbs.



PRUNER ROPE INSULATOR

Insulator provides protection for use near high voltage lines. Tested at 100kV per foot.

PART #	DESCRIPTION	WEIGHT
4005	1/2" diameter x 34" long	.3 lbs.
4004-1	1/2" diameter x 12" long	.6 lbs.



A11004

A10033

REPLACEMENT PRUNER HEAD

Drop forged steel blades have double cutting action and are lightweight and strong.

PART #	DESCRIPTION	WEIGHT
A11004	Pruner head only	1.8 lbs.
A10033	Pulley for pruner arm	.2 lbs.



POLE HEAD

Equipped with adapter to fit standard round or square pruner poles

PART #	DESCRIPTION
A11005	Replacement head for pole pruning saw
4042	Pruner blade cover



PRUNER POLES

1-1/4" DIAMETER ROUND POLES		
LENGTH	PART #	WEIGHT
10'	4109	3.0 lbs.
12'	4111	3.8 lbs.
14'	4113	4.5 lbs.
16'	4115	5.3 lbs.

1-1/2" DIAMETER ROUND POLES		
LENGTH	PART #	WEIGHT
10'	5310	5.3 lbs.
12'	5312	6.5 lbs.
14'	5314	7.6 lbs.
16'	5316	8.8 lbs.

1-1/4" DIAMETER SQUARE POLES		
LENGTH	PART #	WEIGHT
10'	4110	3 lbs.
12'	4112	3.8 lbs.
14'	4114	4.5 lbs.
16'	4116	5.3 lbs.

TREE TRIMMING

These lay-up sticks and pruner poles are made from a high performance fiberglass composition with Kevlar fibers added to make these the strongest poles available. The "JE" series poles are tested at 100kV per foot which make them the ideal choice for line clearance. The "FG" series are lighter and have exceptional bending strength.

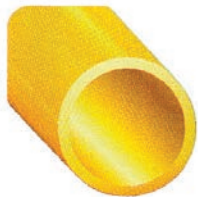

FG Series



JE Series



Rubber Base Cap



Female Ferrule



Male Ferrule



Pole Saw Head

FG SERIES HOLLOW POLES

LENGTH	BASE POLE *	EXTENSION POLE **	SAW HEAD (PS-3) ***	SAW HEAD (PS-3F) ***
6'	FG-6F	FG-6	FG-6S	FG-6SF
8'	FG-8F	FG-8	FG-8S	FG-8SF
10'	FG-10F	FG-10	FG-10S	FG-10SF
12'	FG-12F	FG-12	FG-12S	FG-12SF

JE SERIES FOAM CORE POLES

LENGTH	BASE POLE *	EXTENSION POLE **	SAW HEAD (PS-3) ***	SAW HEAD (PS-3F) ***
6'	JE-6F	JE-6	JE-6S	JE-6SF
8'	JE-8F	JE-8	JE-8S	JE-8SF
10'	JE-10F	JE-10	JE-10S	JE-10SF
12'	JE-12F	JE-12	JE-12S	JE-12SF

BASE POLE *

With rubber cap & female ferrule

EXTENSION POLE **

With male ferrule & female ferrule

SAW HEAD ***

With saw mount & male ferrule



PRUNER KIT

Consisting of: JA14 pruner, PHA-14 adapter and 20' of rope. 1-1/4" cutting capacity.

PART #
PH14-PKG



PRUNER KIT

Consisting of: PH12 pruner, PHA-12 adapter and 20' of rope. 1-1/2" cutting capacity.

PART #
PH12-PKG



OFFSET SAW MOUNT

PART #
PS-3

16" TEFLON SAW BLADE

Fits PS-3 saw mount.

PART #
SB-2



CENTER SAW MOUNT

PART #
PS-3F

16" TRI-EDGE SAW BLADE

Fits PS-3F saw mount.

PART #
SB-16TE

HYDRAULIC SAWS

The power-to-weight ratio of hydraulic tools is significantly higher than most gasoline powered tools, making them the popular choice among professional arborist, right-of-way crews and utilities. These hydraulic tools operate on either open or closed center systems and come with a standard 3/8" NPT Male Adapter. See pages 60 - 61 for couplers, hoses & power units.

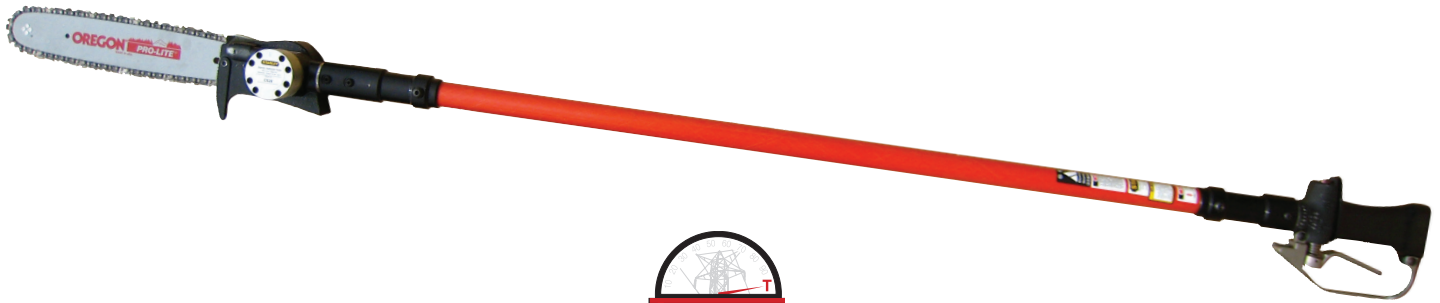

This hydraulic tool is pressure tested prior to shipment.

HYDRAULIC CHAIN SAW

This long reach saw has a 12" saw bar and an automatic chain oiling system. Available in overall lengths of either 75" or 90".

PART #	LENGTH	FLOW RATE	OPERATING PRESSURE	WEIGHT
CS28811	90"	7 - 9 GPM	1,000 - 2,000 PSI	9 lbs.
CS28812	75"	7 - 9 GPM	1,000 - 2,000 PSI	8.4 lbs.

CS25 SERIES HYDRAULIC CHAIN SAWS

Same as the CS28 but with a flow rate of 4-6 GPM.

PART #	LENGTH	OPERATING PRESSURE	WEIGHT
CS25811	90"	1,000 - 2,000 PSI	9 lbs.
CS25812	75"	1,000 - 2,000 PSI	8.4 lbs.

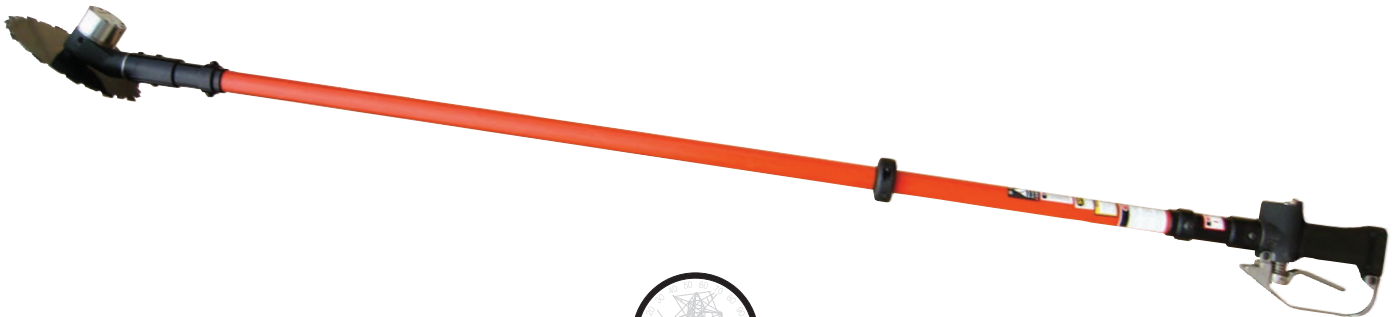

This hydraulic tool is pressure tested prior to shipment.

HYDRAULIC CIRCULAR SAW

This long saw has a 9" blade on an angled head attached to a fiberglass pole. A blade brake reduces "coast-down" time.

PART #	LENGTH	FLOW RATE	OPERATING PRESSURE	WEIGHT
CR27	79"	5 - 7 GPM	1,000 - 2,000 PSI	9.6 lbs.

HYDRAULIC SAWS & PRUNERS

See pages 60 - 61 for hydraulic hoses & couplers.



43178

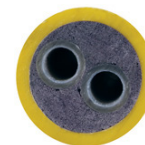

Optional foam filled profile

HYDRAULIC CHAINSAW

Features 5 - 8 GPM flow rate, 1,000 - 2,000 operating pressure PSI, and used with open or closed center hydraulic systems. All models offer anti-kickback chain and automatic chain oiler. Insulated fiberglass tubes are tested to meet OSHA regulation 1910.269.

PART #	LENGTH	DESCRIPTION	WEIGHT
43178	62.5"	Long reach chain saw	8.25 lbs.
38568	75"	Long reach chain saw	9.25 lbs.
43177	88.5"	Long reach chain saw	9.75 lbs.
17140	75"	Foam filled long reach chain saw	9.5 lbs.
17142	88.5"	Foam filled long reach chain saw	10.25 lbs.



HYDRAULIC CIRCULAR SAW

The 9" blade mounted on the angular head makes flush cuts easier and directs chips away from the operator. Used with open or closed center hydraulic systems. Safety features include hand stop collar, two-step trigger and branch stop. Fiberglass tubes are tested to meet OSHA regulation 1910.269.

PART #	LENGTH	FLOW RATE	OPERATING PRESSURE	WEIGHT
43180	82"	4 - 6 GPM	1,000 - 2,000 PSI	9 lbs.



HYDRAULIC UTILITY PRUNER

Heavy cutting capacity cuts branches up to 2". For use with an open center hydraulic system. The full power return quickly forces the blades back open. Insulated fiberglass tubes are tested to meet OSHA regulation 1910.269.

PART #	LENGTH	FLOW RATE	OPERATING PRESSURE	WEIGHT
48520	86"	4 - 6 GPM	1,000 - 2,000 PSI	10.6 lbs.

HYDRAULIC SAWS

See pages 60 - 61 for couplers, hoses & power units.



HYDRAULIC CHAIN SAW

This chain saw produces almost twice as much power as its gasoline engine counterparts but weighs only 6.25 lbs. Comes standard with a 15" bar but 12" & 20" models are available. Excellent saw for all types of wood cutting: trees, limbs, timbers and utility poles. Automatic chain oiler, hand guards & low kickback bars are just some of the features. Overall length 30".

PART #	FLOW RATE	OPERATING PRESSURE
CS06620	7 - 9 GPM	1,500 - 2,000 PSI
CS05620	4 - 6 GPM	1,500 - 2,000 PSI



HYDRAULIC CHAIN SAW

Ideal for large trimming and cut-up removal jobs. The chain and bar can be adjusted without removing the sprocket cover. The handle can be adjusted from a horizontal position to 30 or 60 degrees relative to the bar and chain. Runs open or closed center hydraulic systems. Includes 12" whip hoses with 3/8" NPTF ends. Weighs 8.5 lbs. overall length 26-1/2".

PART #	FLOW RATE	OPERATING PRESSURE
HPS513	4 - 8 GPM	1,000 - 2,000 PSI

BATTERY POWERED SAWS

Other brands and models available.



XCU02PT



XCU03PT

CORDLESS CHAIN SAWS

With zero emissions, lower noise, and considerably less maintenance, the 18V X2 LXT® chain saws are a welcome solution for cutting and trimming applications. They are powered by two 18V LXT® batteries for 36V power and run time. And with the efficient Makita outer rotor brushless motor with direct drive system, users get high power efficiency that is equivalent to a gas chain saw.

Kit includes: (1) 18V X2 (36V) LXT® chain saw, (2) 18V LXT® Lithium-ion 5.0Ah battery (BL1850B), (1) 18V LXT® Lithium-ion dual port charger (dc18rd), (1) guide bar, (1) chain.

PART #	SPEED	BAR LENGTH	CHAIN GAUGE	WEIGHT
XCU02PT	1,650 FPM	12"	.043"	10.1 lbs.
XCU03PT	3,940 FPM	14"	.043"	11.5 lbs.



531-291-646



196208-3



165245-8



442-040-661

CORDLESS CHAIN SAW ACCESSORIES

PART #	DESCRIPTION
531-291-646	12" Saw chain, 3/8" - .043"
165245-8	12" Guide bar
196207-5	14" Saw chain, 3/8" - .050"
196208-3	16" Saw chain, 3/8" - .050"
442-035-661	14" Guide bar
442-040-661	16" Guide bar

GAS POWERED SAWS



DCS5121R



EA4300FR



EA3601FR

GAS POWERED CHAIN SAWS

Makita® 2-stroke power equipment offers fast starts, reduced weight, and compact designs.

PART #	ENGINE	HP	GUIDE BAR	PITCH	WEIGHT
EA3601FR	35 cc	2.3	16"	3/8"	9.2 lbs.
EA4300FR	42 cc	3.0	16"	3/8"	10.8 lbs.
DCS5121R	50 cc	3.3	18"	3/8"	11.9 lbs.



CS-355T



CS-550P

GAS POWERED CHAIN SAWS

Whether you're logging, felling or limbing these saws are built to tackle the toughest jobs.

Powered by a high performance, 2-stroke engine for fast starts and smooth operation.

PART #	ENGINE	BAR LENGTHS	DRY WEIGHT *
CS-352	34.0 cc	14" & 16"	8.8 lbs.
CS-355T	35.8 cc	14" & 16"	8 lbs.
CS-550P	54.1 cc	16" & 18"	13.3 lbs.
CS-800P	80.7 cc	24", 27", 32" & 36"	16.5 lbs.

* Without bar and chain

GAS POWERED SAWS & ACCESSORIES



GAS POWERED PRUNER

Equipped with a powerful and smooth-running 25.4 cc commercial grade engine, this saw is lightweight and extremely dependable. It is extendable from 8'-11" to 12'-2" and the 5' extension puts the overall length past 17'. The ergonomic handle with rubber over-mold offers comfort and improved handling.

PART #
PPT-265



4' EXTENSION

PART #
PPT-040



2-CYCLE OIL

PART #	DESCRIPTION	SIZE
6450001	1 Gallon mix	2.6 oz. bottle
6450002	2 Gallon mix	5.2 oz. bottle



SAFETY CAN

PART #	SIZE
SS-100	1 Gallon
SS-102	2 Gallons



D.O.T. / TRANSPORT / JERRICAN - SAFETY CANS

PART #	CAPACITY
STJ 2010LM	1 Gallon
STJ 2025LM	2.5 Gallons
STJ 2050LM	5 Gallons



TYPE II SAFETY POUR STORAGE CANS

PART #	CAPACITY
SP 200	1 Gallon
SP 250	2.5 Gallons
SP 205	5 Gallons

TOOL HOLDERS & PERSONAL PROTECTION



AERIAL BUCKET TOOL HOLDERS

These tool holders fit on round or square booms. Ratchet strap binders and tool handle holders are included.

PART #	DESCRIPTION
24-02	Circular saw holder
24-03F	Long reach chainsaw holder with locking straps & handle
24-04	Hydraulic pruner holder with locking straps & handle
24-14A	Chainsaw scabbard



103942171



103942230



99988801500



PERSONAL PROTECTION - HEADGEAR

PART #	DESCRIPTION
103942171	Padded ear muffs
103942230	Brush cutter system
99988801500	Helmet system

PERSONAL PROTECTION - LEGWEAR

PART #	DESCRIPTION
103942180	Shin guards
99988801302	36" Chain saw chaps
99988801303	40" Chain saw chaps

TOOL BUCKETS



TE2202

12" x 15"

LEATHER BOTTOM CANVAS TOOL BUCKET

PART #	FEATURES
TE2202	Rope handle only
TE2202-S	Rope handle & swivel snap



TE2200-S

12" x 15"

PLASTIC BOTTOM CANVAS TOOL BUCKET

PART #	FEATURES
TE2200	Rope handle only
TE2200-S	Rope handle & swivel snap
TE2206	Swivel snap & 1 inside pocket
TE2207	Swivel snap with blackwrap



TE2226

8" x 12"

PLASTIC BOTTOM CANVAS TOOL BUCKET

PART #	FEATURES
TE2220	Rope handle only
TE2221	Rope handle with swivel snap
TE2225	Rope handle with blackwrap
TE2226	Rope handle, swivel snap with blackwrap



TE2211

12" x 12"

PLASTIC BOTTOM BLACKWRAP TOOL BUCKETS

PART #	FEATURES
TE2210	Rope handle only with 14 inside pockets
TE2211	Rope handle, swivel snap & 14 inside pockets
TE2215	Rope handle only with 14 outside pockets
TE2216	Rope handle, swivel snap & 14 outside pockets



TE2216

TOOL BUCKETS

These Heavy-Duty tool bags are made of a PVC impregnated, weatherproof fabric. They boast marine-proof rivets, industrial strength double nylon stitching and oversized zippers. Tools are stored vertically for easy identification. The hinged handle is rubber coated and all bags come with a non-slip, extra-wide padded shoulder strap.



OPEN TOP TOOL BAG

40 tiered pockets of varying sizes and 4 zipper pockets.

PART #	SIZE
OT-XL	16-1/2" x 9-1/2" x 18"

CLOSED TOP TOOL BAG

51 tiered pockets of varying sizes and 6 zipper pockets.

PART #	SIZE
CT-LC	13-1/2" x 9-1/2" x 19"



14" x 7" x 9" BLACKWRAP CAMOUFLAGE OVAL TOOL BUCKET

14 inside & 17 outside pockets.

PART #	FEATURES
TE98707	2 Grommets



16" x 9" x 12" OVERSIZED BLACKWRAP CANVAS OVAL TOOL BUCKET

17 inside & 13 outside pockets.

PART #	FEATURES
TE2310	2 Grommets



14" x 7" x 9" BLACKWRAP CANVAS OVAL TOOL BUCKET

15 inside & 13 outside pockets.

PART #	FEATURES
TE2305	2 Grommets



14" x 7" x 9" BLACKWRAP BLACK VINYL OVAL TOOL BUCKET

15 inside & 13 outside pockets.

PART #	FEATURES
TE65710	2 Grommets



14" x 7" x 9" BLACKWRAP MULTI-PURPOSE CANVAS OVAL TOOL BUCKET

13 outside pockets.

PART #	FEATURES
TE2300	No Grommets
TE2302	2 Grommets



14" x 7" x 9" BLACKWRAP OVAL TOOL BUCKET

14 inside pockets.

PART #	FEATURES
TE2344	2 Grommets

CANVAS GEAR BAGS

Many other sizes, styles and pocket combinations are available. Call Tallman Equipment for more information.



24" x 10" x 14"
CANVAS GEAR BAG
WITH MOLDED RUBBER BOTTOM

PART #	FEATURES
TE2110	No pockets
TE2111	1 Outside pocket
TE2112	1 Inside pocket



24" x 10" x 14"
HEAVY WEIGHT CANVAS GEAR BAG

PART #	FEATURES
62-235	2 Outside pockets



OVERSIZED CANVAS UTILITY BAGS

PART #	SIZE
TE2140	19" x 4" x 20"
TE2145	19" x 8" x 16"
TE2150	19" x 12" x 16"
TE2155	19" x 15" x 16"



24" x 10" x 21"
HEAVY CANVAS GEAR BAG

PART #	FEATURES
TE2125	1 Inside pocket



15" x 8" x 13"
CANVAS GEAR BAG
WITH MOLDED RUBBER BOTTOM

PART #	FEATURES
TE2101	Standard bag only - no pockets
TE2102	14 Inside pockets & 10 outside pockets

VINYL GEAR BAGS



ORANGE VINYL GEAR BAG

Plastic buckle closures. Other colors available.

PART #	SIZE
62246	24" x 10" x 14"



YELLOW VINYL GEAR BAG

Also available in black, blue and orange. Specify color when ordering. Zipper closure.

PART #	SIZE
62510	24" x 10" x 12"



ORANGE VINYL GEAR BAG

2 outside pockets, shoulder strap, & roll-up rain flap.

PART #	SIZE
TE2130	24" x 10" x 18"



TOOL BAG

Heavy gauge 2" molded rubber lip is double stitched into the bottom of the bag to prevent water from seeping in. Durable in cold weather.

PART #
45333B3R5S



VINYL TOOL BAG WITH WHEELS

A rubber bottom tool bag with wheels is ideal for transporting equipment between trucks or to remote work sites. Features heavy-duty rubber wheels designed for years of use. Push button handle retracts when not in use.

PART #
41333O1R5W1



CAMOUFLAGE CANVAS BAG

Camouflage canvas bag with rubber bottom features 6" diameter heavy duty rubber wheels and retractable button handle. Ideal for transporting equipment in rough terrain.

PART #
41333C7R5W3

SPECIALTY TOOL BAGS



YELLOW VINYL AMPACT BAG

Swivel snap rope handle & elastic cartridge holders.

PART #	SIZE
TE2230	8" x 12"



CANVAS AMPACT BAG

Swivel snap rope handle,
3 outside pockets & elastic cartridge holders.

PART #	SIZE
TE2235	10" x 12"



Bat option

BLACKWRAP OVAL TOOL BUCKET

Oversized bucket with 17 inside pockets, 2 grommets,
Available with a bat option. 16" x 9" x 12".

PART #
TE2307



BACK PACK ROPE BAG

3 outside mesh pockets with hook and loop closures.
Quick adjust friction buckles, drawstring closure and carry handle. Available in 120', 150', 200', 225', and 300' models.

PART #	LENGTH
4469B1	150'



LINE HOSE BAG

Works great for armor rod!

PART #	SIZE
TE2036	8" x 36"
TE2048	8" x 48"
TE2060	8" x 60"

LINEMAN BACKPACK

Wide opening holds helmets, belts and other equipment. Large front pocket for separate storage. Padded back with adjustable shoulder and chest straps.

Durable double stitched plastic bottom with drain holes.

PART #	DIMENSIONS
5185ORA	23"H x 18"L x 10"W



TRADESMAN PRO™ BACKPACK

Features 39 pockets for tons of tool storage. Orange interior. Wide opening fits power drills, meters, flashlights, etc. Large front pocket fits fish tapes. Tough durable molded bottom.

PART #	DIMENSIONS
55421-BP	18"H x 14"L x 7"W



TRADESMAN PRO 8-INCH TOTE

20 pockets for greater tool storage. Orange interior for easy tool visibility. Removable zipper bag. Tough, durable feet protect from the elements. 1680D ballistic weave for durability.

PART #	DIMENSIONS
55415-8	17"H x 8"L x 8"W



TRADESMAN PRO 10-INCH TOTE

40 pockets for maximum tool storage. Orange interior for easy tool visibility.

Removable zipper bag. Tough, durable feet protect from the elements.

1680D ballistic weave for durability.

PART #	DIMENSIONS
55416-10	12"H x 10"L x 10"W



TRADESMAN PRO EXTREME ELECTRICIAN'S BAG

78 pockets for extreme tool storage. Orange interior for easy tool visibility.

Wide center with removable pockets for easy access to tools. Tough, durable molded bottom protects from the elements. 1680D ballistic weave for durability.

PART #
55417-18



TRADESMAN PRO™ ORGANIZER ULTIMATE ELECTRICIAN'S BAG

55 pockets for ultimate tool storage. Orange interior for easy tool visibility.

Wide opening fits power drills, meters, laptops, etc. Tough, durable molded bottom protects from the elements. 1680D ballistic weave for durability.

PART #
55418-19



AERIAL TOOL BUCKETS



TE2325



TE2330



TE2333



TE2340

14" x 7" x 9"

BLACKWRAP OVAL ARIAL TOOL BUCKET

PART #	DESCRIPTION
TE2325	5 Inside pockets
TE2330	6 Inside pockets
TE2333	6 Inside pockets, bat option
TE2340	14 Inside pockets



14" x 7" x 9"

BLACKWRAP SUSPENSION BUCKET

PART #	DESCRIPTION
TE2350	14 Inside pockets
TE2355	14 Outside pockets



TE2360-H

14" x 7" x 9"

CANVAS OVAL TOOL BUCKET

PART #	DESCRIPTION	DIMENSIONS
TE2360	15 Inside pockets, no hooks	14" x 7" x 9"
TE2360-H	15 Inside pockets, with hooks	14" x 7" x 9"



TE45675

LARGE BLACKWRAP AERIAL BUCKET

PART #	DESCRIPTION	SIZE
TE2375	No pockets	14" x 7" x 20"
TE2377	5 Inside pockets	14" x 7" x 20"
TE45675	5 Inside compartments, web strap and locking snap	16" x 9" x 20"

AERIAL BUCKET TOOL APRONS



CANVAS AUGER BIT BAG
14-1/2" x 21" with 9 pockets.

PART #
TE10305



CANVAS APRON
18" x 11" with 7 pockets.

PART #
TE2401



CANVAS TOOL APRON
20" x 18" with 9 pockets & TE2500 hooks.

PART #
TE2415



MAGNETIC STRIP CANVAS TOOL APRON
24" x 22" with 18 pockets & no hooks.

PART #
TE43170



VINYL TOOL APRON
24" x 22" with 18 pockets & DN2500 hooks.

PART #
TE2425



MAGNETIC STRIP VINYL TOOL APRON
24" x 22" with 18 pockets & no hooks.

PART #
TE43162

AERIAL BUCKET HOOKS & TOOL BOARDS



DN2500

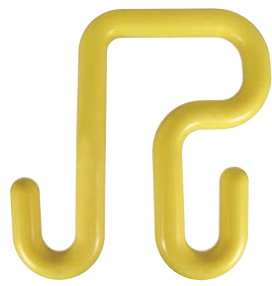

DN2502

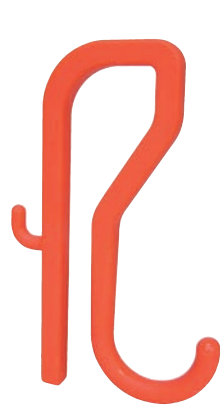

DN2506



DN2506-3

NYLON, POLYMER & PVC BUCKET HOOKS

PART #	DESCRIPTION	STOCK DIAMETER
DN2500	Yellow polymer hook for 2" lip	11/16" Round
DN2502	Yellow polymer hook for 3" lip	11/16" Round
DN2503	Nylon polymer hook for 3" lip	5/8" Round
DN2506	Red nylon single with back hook for 2" lip	3/4" Square
DN2506-3	Red nylon triple with back hook for 2" lip	3/4" Square



TE2450



TO-1

TOOL BOARDS

PART #	DIMENSIONS	DESCRIPTION
TE2450	20" x 18"	Fiberglass board with nut runner holder
TE2450-L	20" x 18"	Fiberglass board with flashlight holder
TO-1	18" x 20"	Plastic board shown here in the standard layout, you can design this board to suit your needs

AERIAL BUCKET TOOL HOLDERS



24-02



24-03F



24-04



24-12A



24-12AH



24-14A



24-16A

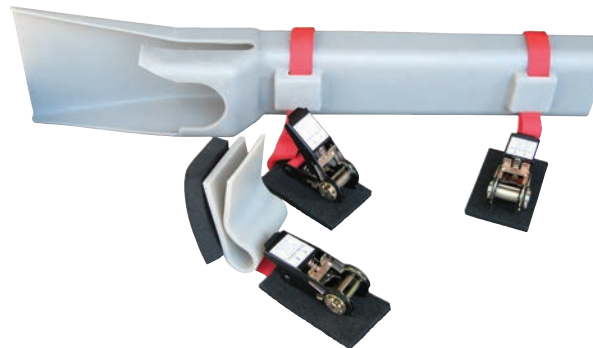

BSH-4

AERIAL BUCKET AND BOOM TOOL HOLDERS

These tool holders fit on round or square booms. Ratchet strap binders and tool handle holders are included.

PART #	DESCRIPTION
24-02	Circular saw holder
24-03F	Long reach chainsaw holder with handle holder
24-04	Hydraulic pruner holder
24-12A	Impact tool holder
24-12AH	Impact tool holder with scabbard
24-14A	Adjustable chainsaw scabbard with liner
24-16A	Fiberglass Litebox® holder
BSH-4	Boom mounted long reach chain saw holder

AERIAL BUCKET TOOL HOLDERS & TRAYS



VINYL TOOL HOLDER

10" x 19" with 2 pockets.

PART #
TE2475



PLASTIC TOOL HOLDER

3 Pocket holder with 2 grommets.

PART #
TE2480



PLASTIC TOOL HOLDER

15" x 25" 4 Pocket holder.

PART #
PCP-4



OUTSIDE TOOL TRAY

Compact, lightweight polyethylene tray.
Fits buckets with or without liners. 7-1/2" x 6" x 14".

PART #
05-951



INSIDE - OUTSIDE TOOL TRAY

Hangs on either outside or inside of bucket using standard hanger hooks (not included). 7-1/2" x 6" x 14".

PART #
05-918-1



SHALLOW PLASTIC TOOL TRAY

Made of high density polyethylene.
Inside dimensions are 8" x 8" x 19". Other sizes are available.

PART #
1TB



DEEP PLASTIC TOOL TRAY

The strong magnetic strip grabs and holds hardware and other metal items. 5-1/4" x 11" x 24".

PART #
TE3190

AERIAL BUCKET COVERS



2936



2932

SOFT NYLON BUCKET COVERS

Made of heavy-weight vinyl coated nylon, these bucket covers are available in a variety of sizes and shapes. All bucket covers have an elastic band sewn into the hem to snugly fit the bucket and a 4' lanyard with snap.

Covers are also offered with rigid foam inserts creating a dome effect for maximum water run-off.

PART #	FITS BUCKET SIZES:	COVER
2902	24" x 24" to 24" x 30"	Soft cover
2932	24" x 24" to 24" x 30"	Foam insert
2906	24" x 48"	Soft cover
2936	24" x 48"	Foam insert

Many other sizes are available. Order by outside lip dimensions.



28L32



2L28S

RIGID PLASTIC BUCKET COVERS

These rigid covers are made of a high density polyethylene plastic and are shaped to help shed ice & snow.

They are easily installed or removed by one person. Available with strap & buckles or snap cord closure.

PART #	BUCKET MANUFACTURER	SIZE
2L28S	Holan, Altec, Telelect	29-1/2" x 29-1/2"
28L32	Versalift, Altec, Hi-Ranger, Holan, Liftall, Telelect	28" x 32"

Many other sizes are available including kidney-shaped. Order by outside lip dimensions & vehicle manufacturer.

ANTI-FATIGUE FLOOR MATS

The PVC material is tested to be dielectrically non-conductive and will not sustain combustion. It is highly resistant to mold, heat and cold.

PART #	DIMENSIONS - DESCRIPTION
50580111	24" x 24"
50580112	24" x 30"
50580113	24" x 48"
50580114	Any size - priced by the sq. foot
50580116	2' wide by 50' long - roll





SELF RESCUE SYSTEM

This system has all of the components for self-rescue or the rescue of a fellow employee. An "Anti-Panic" safety feature stops the descent if the user compresses the handle too hard. The kit includes 1/2" braided rope in lengths from 50', 75', 100'. Specify length when ordering.

PART #
101SR - LENGTH



BUCKIT RESTRAINT SYSTEM

The easy-to-install. Keeps the user secure in the bucket, while allowing freedom to move and work. Featuring 10,000 lb. rated nylon webbing that can be used with any two dee ring belt, including arborist saddles. System fits single-man and man-and-a-half buckets.

PART #
126A



RATCHETING BOOM STRAP

5,000 lb. rated boom strap provides a secure anchor point on the bucket truck boom.

PART #
3809R



HURT MAN BUCKET TRUCK RESCUE SYSTEM

This system is ideal for easily lifting an injured victim out of an aerial basket. The water resistant bag is designed to be mounted on the boom where it can be easily accessed in the event of a rescue.

PART #
3813



AFTER FALL RESCUE LADDER

A collapsible ladder inside a vinyl coated bag that mounts onto the boom or the fall arrest anchorage. Pulls free if the user should fall, allowing them to climb back to safety. Connects to the harness using a snap hook connected to a tag line.

PART #
102SRS



BUCK SELF RESCUE SYSTEM

Ideal for the one man crew. The system contains a specially designed bag that releases a ladder, an ascender, descender & 50' of rope. Longer lengths are available upon request. Rated to 330 lbs.

PART #
106-50

FULL BODY HARNESES

HARNESS SIZING MATRIX

Standard sizes are Small, Medium, Large, & X-Large. Non standard sizes are 2XL and 3XL and are not returnable.

USERS HEIGHT	CHEST SIZE					
	34 - 36	38 - 40	42 - 44	46 - 48	50 - 54	56 - 60
5' 4" - 5' 7"	S	S	M	L	XL	2XL
5' 8" - 5' 11"	S	M	L	XL	2XL	3XL
6' - 6' 3"	M	M	L	XL	2XL	3XL
6' 3" +	L	L	XL	XL	2XL	3XL

ECONOMY HARNESES

Standard design Economy Harnesses are made from nylon webbing with orange upper and black lower sections Meets ASTM F887 Electric Arc Performance Requirements and is manufactured to meet ANSI Z359.11-14 standards.

'X' STYLE FULL BODY HARNESS

Full body harness that features patented split tongue quick connect buckles with leather chafes on the leg straps and at the torso for height adjustment. Web dorsal loop attachment. Reinforced web front loop that can be used for rescue or rope/cable grab.

PART #
60358C700



'H' STYLE FULL BODY HARNESS

'H' style full body harness made from nylon webbing with orange upper and black lower sections with a web dorsal loop attachment and hook and loop chest strap. Interlocking leg strap buckles with leather chafes. Standard friction buckle for height adjustment.

PART #
6393700



UNIVERSAL 'H' STYLE FULL BODY HARNESS

Full body harness made from nylon webbing with grommetted leg straps and buckles, with a interlocking buckle chest strap and a web dorsal loop attachment.

PART #	SIZE
U6494700	M, L, XL
U6494700-2XL	2XL
U6494700-3XL	3XL



FULL BODY HARNESSSES

Standard design Basic Harnesses are available in both "H" & "X" styles and have contrasting color upper and lower sections. Harnesses meets ASTM F887 Electric Arc Performance Requirements and manufactured to meet ANSI Z359.11-14 standards. Non-standard sizes available upon request. See page 99 for the harness sizing matrix.



'X' STYLE FULL BODY HARNESS

An 'X' style full body mini back pad harness that offers comfort and ease in donning. Unique shoulder pads are made from sateen fabric with fire resistant padding. Features patented quick connect buckles at the front and leg straps for easy donning, a web loop at the sternum and a 5000 lb rated Nylon dorsal loop that eliminates metal and allows user to girth hitch their energy absorber (can be ordered with a dorsal dee).

PART #
603S8C700K4



'H' STYLE MINI BUCKFIT™

Harness that features a patented split tongue buckle and leather chafes on chest and leg straps. This harness has a web dorsal loop attachment and friction buckle mounted on vertical shoulder strap for height adjustments. Meets ANSI and/or ASTM standards, ASTM F887 Electric Arc Performance requirements and meets pending ANSI Z359.11-14.

PART #
68D98C700K3



'H' STYLE FULL BODY HARNESS

Full body harness that features a web dorsal loop attachment. A Kevlar mesh shell that is designed that is designed to breathe. Foam padded shoulder and leg pads that add overall comfort. Hook and loop chest strap. Patented split tongue quick connect buckles with leather chafes on leg straps. Spring loaded friction buckles for height adjustment.

PART #
637G8C700K1



'X' STYLE FULL BODY HARNESS

Full body harness with a web dorsal loop attachment with a Kevlar mesh shell that is designed to breathe. An FR foam padded shoulder and leg pads add to overall comfort. Split tongue quick connect buckles with leather chafes on the leg straps and at the torso for height adjustment. A reinforced web front loop can be used for rescue or with a rope/cable grab. Made from nylon webbing with silver upper and black lower sections.

PART #
603S8C700K1

FULL BODY HARNESSSES

Standard design Basic Harnesses are available in both "H" & "X" styles and have contrasting color upper and lower sections. Harnesses meets ASTM F887 Electric Arc Performance Requirements and manufactured to meet ANSI Z359.11-14 standards. Non-standard sizes available upon request. See page 99 for the harness sizing matrix.

ACCESS™ TOWER HARNESS

The Access™ 'Y' style harness, body belt combination features five dee rings: one at the dorsal, one at the sternum, one at the waist, and two for work positioning. Easy to put on by stepping into the belt, pulling the 'Y' over head and connecting a carabiner to the 5,000 lb. rated loop at the waist. Features shoulder pads, and wide leg pads with patented quick connect buckles for added comfort. The harness neck features a 'U' designed stitch pattern making the opening wider eliminating neck irritation. Buckle in front and back adjust height to create a snug fit. Body belt features tool loops, accessory snap and-rings. Belt tightens using two friction buckles in front of the work positioning dees.



PART #
61992

BUCKTECH™ AR

The BuckTech AR Tower Harness features a low profile sternal dee ring for use with mobile fall arrestors and rope grabs. The chest strap adjustment buckles allow the user to properly position sternal dee ring and prevent it from sliding up during a fall. Features aluminum dee rings reduce overall weight, Add-on bridge with a sliding aluminum dee ring can be quickly attached for suspension eliminating the need for a spreader snap, The front and rear vertical adjustments allows for proper positioning of the rear dorsal dee ring, Quick connect chest and leg strap buckles, Removable belt strap allows for adding of tool/equipment bags.



PART #
68K966K6

LINEPRO™ TOWER HARNESS

The best body belt in the industry (Model 2000M) is incorporated in the tower harness, giving the user seven dee rings: dorsal dee ring, sternal dee ring, umbilical dee ring, pigtail with a dee ring, and two full float work positioning dee rings. Harness features shoulder pads and wide leg pads with patented quick connect buckles. The harness neck features a 'U' designed stitch pattern making the opening wider eliminating neck irritation. Buckle in front and back adjust height to create a snug fit. Body belt is hand crafted of the highest quality leather and features a 5-1/2" cushioned back reinforced with rawhide lace, tool loops, accessory snap and-rings. The floating dees provide 4" of lateral movement. Belt tightens using two friction buckles in front of the work positioning dees. Harness is multifunctional and can be used on towers, helicopters and on wood poles.



PART #
63992

LANYARDS

BUCK ARREST WEB LANYARDS

16" shock pack covered by a water resistant nylon tube. Meets ANSI Z359.13-2013 and ASTM F887 standards.



6VV114S2



64V114S2



6VV124S2

2 LOCKING SNAP HOOKS

PART #	LENGTH
6VV114S2	4'
6VV114.5S2	4-1/2'
6VV116S2	6'
6VV124S2	Adjustable 4'
6VV125S2	Adjustable 5'
6VV126S2	Adjustable 6'

1 LOCKING SNAP HOOK & 1 WEB LOOP

PART #	LENGTH
64V114S2	4'
64V114.5S2	4-1/2'
64V116S2	6'
64V124S2	Adjustable 4'
64V125S2	Adjustable 5'
64V126S2	Adjustable 6'

BUCK STOP LANYARDS

6" shock pad covered by a clear shrink tube. Meets ANSI Z359.13-2013 and ASTM F887 standards.



5VV114S1



54V114S1



5VV126S1

2 LOCKING SNAP HOOKS

PART #	LENGTH
5VV114S1	4'
5VV114.5S1	4-1/2'
5VV116S1	6'
5VV124S1	Adjustable 4'
5VV125S1	Adjustable 5'
5VV126S1	Adjustable 6'

1 LOCKING SNAP HOOK & 1 WEB LOOP

PART #	LENGTH
54V114S1	4'
54V114.5S1	4-1/2'
54V116S1	6'
54V124S1	Adjustable 4'
54V125S1	Adjustable 5'
54V126S1	Adjustable 6'

LANYARDS

BUCKYARD FR LANYARDS

Interior materials stretch 42" to reduce the arresting force to less than 900 lbs. Meets ANSI Z359.13-2013 and ASTM F887 standards.



8VV114S1



84V114S1

2 LOCKING SNAP HOOKS

PART #	LENGTH
8VV114S1	4'
8VV114.5S1	4-1/2'
8VV115S1	5'
8VV116S1	6'

1 LOCKING SNAP HOOK & 1 WEB LOOP

PART #	LENGTH
84V114S1	4'
84V114.5S1	4-1/2'
84V115S1	5'
84V116S1	6'

BUCKYARD STRETCH FR LANYARDS

Same benefits of the Buckyard™ but with the addition of an elastic bungee. Meets ANSI Z359.13-2013 and ASTM F887 standards.



8VV714S1



84V714S1

2 LOCKING SNAP HOOKS

PART #	LENGTH
8VV714S1	4'
8VV714.5S1	4-1/2'
8VV716S1	6'

1 LOCKING SNAP HOOK & 1 WEB LOOP

PART #	LENGTH
84V714S1	4'
84V714.5S1	4-1/2'
84V716S1	6'

DUAL LANYARDS

Dual Lanyard Fall Arrest Systems allow the user to be continually attached to the structure starting from the ground, all the way to the top of the structure, and back down to the ground. Rescue loops are built into the Dual Lanyard Fall Arrest System.



BUCK COMBOYARD™

Lanyard features a 5' dual tie-back lanyard with wear guard and rescue loops and 12 foot fall ANSI rated shock absorber. Tie Back Snaps have a 5,000 lb. rated gate that can be used in multiple applications. Two ANSI rated Big BuckSnaps™ are also included to make this lanyard even more versatile. Big BuckSnaps™ are designed to fit up to 4" angle iron and feature radiused inside edges to slide onto conductor without damaging it.

PART #
5V67AQ1



BUCK STOP™ DUAL LANYARD

Features two 30342 Big BuckSnaps™ that have a 3-11/32" gate opening, and locking rope snap attachment. Red rescue loops facilitate the rescue of an injured worker.

PART #	MODEL OPTION
5V6716RD+HS1	Locking snap hook attachment
546716RD+HS1	Web loop attachment



BUCK STOP™ DUAL LANYARD

Features two 30351 Locking Ladder Snaps that have a 2-1/4" gate opening, and a locking rope snap. Red rescue loops facilitate the rescue of an injured worker.

PART #	MODEL OPTION
5V6716RD+4S1	Locking snap hook attachment
546716RD+4S1	Web loop attachment



BUCK STEPCLIMB™ LANYARD

The Buck StepClimb™ lanyard provides a safe, easy way to ascend and descend a tower using the existing step bolts. An aluminum snap hook is used to connect to the harness dorsal attachment and keeps the overall weight at a mere 3 lbs.

PART #
5+R6715RD3S1



LIGHTWEIGHT "Y" LANYARD

The new light weight 'Y' lanyard features aluminum hardware and weighs in at only 5 lbs. Aluminum pelican hooks have a 2-1/2" gate opening that can be attached to steel lattice.

The elastic core reduces the length of each leg a full 18" when fully relaxed reducing trip hazards and tangling. Rescue loops aid in rescue without putting another worker in danger. 6' overall length. Meets Arc Flash requirements in ASTM F887 and OSHA 1926.954 as well as ANSI 3600 lb. gate strength requirements.

PART #
5+R6716RD1S1+Z

BASHLIN TOOL BELT SIZING CHART

Proper sizing is one of the most important considerations in the purchase of a lineman's tool belt. An improperly sized belt is uncomfortable and may cause an accident or injury. Bashlin tool belts are measured by the "D" size, which is the distance between the heels of the D-rings. All BASHLIN linemen's tool belts must be ordered according to the "D" size.

TO FIND YOUR "D" SIZE



STEP 1

Locate the point where the heel of the "D" ring should rest. As the photo illustrates, this is approximately 4" down from the top of the hip bone.



STEP 2

Begin to measure from this point. Measure around the buttocks to the same point on the opposite side.



BASHLIN TOOL BELTS

See page 105 for Bashlin tool belt sizing instructions.



88UX4DCC

EZ RIDER

Like working in a "Rocking Chair". Saddle design relieves hip and leg pressure and the four d-rings work great with all the fall protection devices. Worn slightly higher than a standard tool belt.

PART #	MATERIAL	WEIGHT
88UX4DCC	Leather	7 lbs.
88UX4DMP	Nylon mesh	6.5 lbs.



1515PX4D

EZ RIDER LITE

Lightweight belt that is available with either lower metal "D" rings or nylon loops. Choice of a nylon or leather cushion.

PART #	MATERIAL	WEIGHT
1515PXCC	Leather with lower nylon loops	4.7 lbs.
1515PX	Nylon mesh with lower nylon loops	4.5 lbs.
1515PX4D	Nylon mesh with metal lower d-rings	4.6 lbs.
1515PX4DCC	Leather with metal lower d-rings	4.8 lbs.



Q88BMX4DCC

BMX BACKSAVER SERIES

PART #	MATERIAL	WEIGHT
Q88BMX4D	Non padded leather	9 lbs.
Q88BMX4DMP	Nylon mesh	7 lbs.
Q88BMX4DCC	Extra soft padded leather	8 lbs.

BASHLIN TOOL BELTS

See page 105 for Bashlin tool belt sizing instructions.

LABRADOR "AMIGO"

This belt offers the comfort of an old friend. Easy donning quick release buckle with easy to adjust nylon webbing. Available with moisture wicking nylon or soft leather cushion.

PART #	MATERIAL	WEIGHT
Q88GX4DCC	Leather	6 lbs.
Q88GX4DMP	Nylon mesh	5.5 lbs.



Q88GX4DCC

LABRADOR "YUKON"

Rugged design to take you to the top. Dependable double tongue design with leather faced nylon billet. Available with moisture wicking nylon or soft leather cushion.

PART #	MATERIAL	WEIGHT
88GX4DCC	Leather	6.5 lbs.
88GX4DMP	Nylon mesh	5.5 lbs.



88GX4DCC

LABRADOR "LIBERTY"

The freedom of a single tongue. Features a full floating d-saddle and a soft leather cushion.

PART #	MATERIAL	WEIGHT
88MX4DCC	Leather	5.5 lbs.
88MX4DMP	Nylon mesh	5 lbs.



88MX4DCC

BASHLIN TOOL BELT ACCESSORIES

See page 105 for Bashlin tool belt sizing instructions.

LABRADOR "SIERRA"

Converts a two d-ring belt into a four d-ring belt.

Has a moisture wicking nylon mesh cushion and features a tongue & buckle billet with nylon reinforced leather. Sized 4"- 6" larger than waist size, to compensate for clothing.



PART #	SIZE	WAIST SIZE	WEIGHT
83H2D-S (D18-D21)	Small	32"- 40"	3.5 lbs.
83H2D-M (D22-D25)	Medium	36"- 44"	3.5 lbs.
83H2D-L (D26-D28)	Large	40"- 48"	3.5 lbs.
83H2D-X (D29-D32)	X-Large	42"- 50"	3.5 lbs.

LABRADOR "TUCSON"

Easily converts a two d-ring belt into a four d-ring belt.

Has a moisture wicking nylon mesh cushion and features a quick lock buckle. Sized 4"- 6" larger than waist size, to compensate for clothing.



PART #	SIZE	WAIST SIZE	WEIGHT
Q83H2D-S (D18-D21)	Small	32"- 40"	3 lbs.
Q83H2D-M (D22-D25)	Medium	36"- 44"	3 lbs.
Q83H2D-L (D26-D28)	Large	40"- 48"	3 lbs.
Q83H2D-X (D29-D32)	X-Large	42"- 50"	3 lbs.

LABRADOR "LOBO"

Easily converts a two d-ring belt into a four d-ring belt and has a moisture wicking nylon mesh cushion. Features billet style buckle & uses Back-A-Line technology. Sized 4"- 6" larger than waist size, to compensate for clothing.



PART #	D-SIZE	SIZE	WAIST SIZE	WEIGHT
83BDH-S	(D18-D21)	Small	32"- 40"	4 lbs.
83BDH-M	(D22-D25)	Medium	36"- 44"	4 lbs.
83BDH-L	(D26-D28)	Large	40"- 48"	4 lbs.
83BDH-X	(D29-D32)	X-Large	42"- 50"	4 lbs.

BACK-A-LINE SUPPORT BELT

A detachable gut strap that incorporates the back-a-line support device.

According to American Osteopathic Academy of Sports Medicine this support belt helps to reduce back fatigue by supporting the back muscles and provides true support. THIS IS NOT A SAFETY BELT.



PART #	SIZE	WAIST SIZE	WEIGHT
83B-S	Small	32"- 40"	2.2 lbs.
83B-M	Medium	36"- 44"	2.2 lbs.
83B-L	Large	40"- 48"	2.2 lbs.
83B-X	X-Large	42"- 50"	2.2 lbs.

BUCKINGHAM BODY BELT SIZING CHART

BUCKINGHAM BODY BELT SIZING

1. Determine your 'Y' measurement (see method and diagram below)
2. Determine what Class your Body Belt is in using the chart below (ex. A 2000M belt is in Class 1)
3. Find your 'Y' measurement and then go across to the column that has your Class belt in it and this is the D-size you need to order
Example: Your 'Y' measurement is 24" and you want a Class 1 (2000M) Body Belt you would order a size 26.

CLASS 1 LEATHER BELTS	2000M, 2000EM, 20003M, 20005M, 20006M, 20182M, 2107M 1988M, 1958, 1962M, 19655M, 1902, 1993F, 1994F, 1994FR, 4200, 20192M
CLASS 2 LIGHTWEIGHT BELTS	2012M, 2013M, 2014M, 2015M, 2017M, 2018M, 2019M

X - Distance from waist to top of hip bone where body belt is typically worn.
(This is were you get your y measurement)

Y - Measurement is from front of hip bone around the back to the front of the other hip bone.
(Typically from seam of pants to seam of pants)

	Y MEASUREMENT	SIZE TO ORDER	
		Class 1	Class 2
Tape Measurement / Sizing Belt Measurement	16	18	20
	17	19	21
	18	20	22
	19	21	23
	20	22	24
	21	23	25
	22	24	26
	23	25	27
	24	26	28
	25	27	29
	26	28	30
	27	29	31
	28	30	32
	29	31	33
	30	32	34
	31	33	35
32	34	36	
33	35	37	
34 (MAX)	36	38	
Green Numbers = Standard Sizes Red Numbers = Non Standard Size			

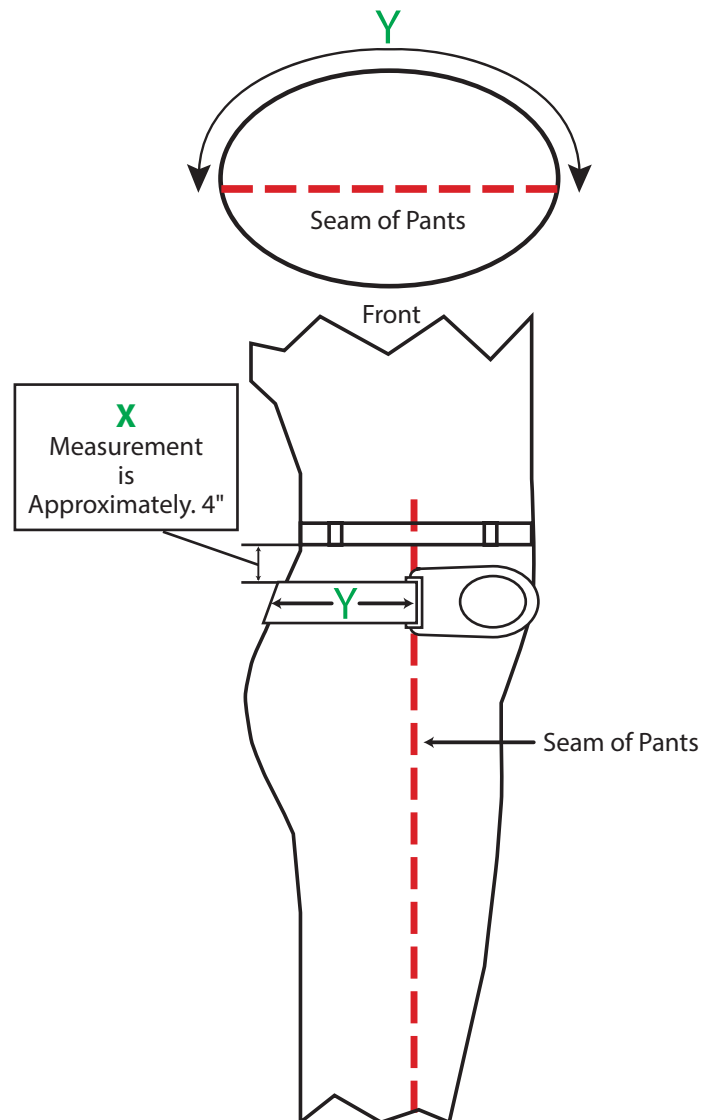

BUCKINGHAM BODY BELTS

See page 109 for Buckingham body belt sizing instructions.



2000EM BODY BELT

Full float body belt with a 5-1/2" foam cushioned pad reinforced with rawhide lace. The belt strap is leather with a nylon center to provide strength and longer life. The 4 floating in-line dees provide a 4" lateral movement to reduce wear on the pole strap.

PART #	SIZING	COLOR	WEIGHT
20002M	Class 1	Black	7 lbs.



2018M

LIGHT WEIGHT FULL FLOAT BODY BELT

The new stacked 2018M 4 dee body belt features: Dri-lex® lined, stacked dee rings, 2 large full float double bar dee, 2 small dee rings. Removable MAN RATED gut strap. (Must be used with a Buckingham provided gut strap).

PART #	SIZING	WEIGHT
2018M	Class 2	7.5 lbs.



2019M

LIGHT WEIGHT FULL FLOAT BODY BELT

New 2019M 4 Dee Body Belt features Dri-lex® lined, stacked dee rings, 2 large full float double bar dee, 2 small dee rings and back support, no gut strap.

PART #	SIZING	WEIGHT
2019M	Class 2	6.72 lbs.

BUCKINGHAM BODY BELTS

See page 109 for Buckingham body belt sizing instructions.



20122EM-BH

HERITAGE™ IN-LINE 4-DEE BODY BELT

The Buckingham 4-Dee In-Line Heritage Belt has the profile of a 2-dee ring belt with the convenience of a 4-dee belt.

PART #	WEIGHT
20122EM-BH	6 lbs.



20182M-BH

HERITAGE™ MOBILITY BELT

With the same features as the 20192M-BH, this belt also has four Stack Dee rings and supports use of Wood Pole Fall Restriction Devices like the new SuperSqueeze™. Your back will thank you for the fully padded 8-3/4" high back.

PART #	WEIGHT
20182M-BH	7.75 lbs.



20192M-BH

HERITAGE™ SHORT BACK MOBILITY BELT

The revolutionary mobility belt offers a man rated upper belt strap that is bound to the lower work positions strap by 1-3/4" web. The four dee ring belt supports the use of wood pole fall restriction devices. Fully padded 7" high back.

PART #	SIZING	WEIGHT
20192M-BH	Class 1	7.15 lbs.

BUCKINGHAM BODY BELTS

See page 109 for Buckingham Body Belt sizing instructions.



2100M-BL



2100M BODY BELT

The stacked 2100M 4 Dee Body Belt features:

2 large full float double bar dee rings, 2 small dee rings and a 9" back pad waist strap only, no upper gut strap.

PART #	SIZING	COLOR	WEIGHT
2100M-BR	Class 1	Brown	7.3 lbs.
2100M-BL	Class 1	Black	7.3 lbs.
2100M-BU	Class 1	Burgundy	7.3 lbs.



2107M-BL



2107M BODY BELT

The stacked 2107M 4 Dee Body Belt features: 2 large full float double bar dee rings 2 small dee rings 9" padded back pad, Removable MAN RATED gut strap (Must be used with a Buckingham provided MAN RATED gut strap).

PART #	SIZING	COLOR	WEIGHT
2107M-BR	Class 1	Brown	9.2 lbs.
2107M-BL	Class 1	Black	9.2 lbs.
2107M-BU	Class 1	Burgundy	9.2 lbs.

BUCKINGHAM BODY BELT ACCESSORIES



MAN RATED GUT STRAP

Model 6263 is able to be used with any two dee body belt and is completely adjustable for users comfort. Belt features 5,000 lb. man rated connections, leather lined strap, and standard tongue buckle. (Small, Medium, Large, & Extra Large sizes)
Belt size waist size: Small 28-32, Medium 32-36, Large 36-40, X-Large 40-44.

PART #
6263



MAN RATED GUT STRAP

Model 6264 is able to be used with any two dee body belt and is completely adjustable for users comfort. Belt features 5,000 lb. man rated connections, leather lined strap, and easy to use quick connect buckles. (Small, Medium, Large, & Extra Large sizes)
Belt size waist size: Small 28-32, Medium 32-36, Large 36-40, X-Large 40-44.

PART #
6264



SUSPENDERS

Adjustable belt supporter made of 3/4" leather with shoulder pads.

PART #	MATERIAL
6258	Leather
6259	Nylon



WAIST BELT

A 4-ply nylon 1-3/4" waist belt with a wide leather pad for support and comfort. Not to be used as a support belt.

PART #	SIZES
6256	S-M-L-XL



GUT STRAP

1-3/4" leather waist belt with 4 buckles and snaps. Supports a tool belt. Not to be used as a support belt.

PART #	SIZES
6257	S-M-L-XL

BODY BELT POUCHES & BAGS



TE2020



TE2022

LEATHER NUT & BOLT POUCHES

PART #	DESCRIPTION	COLORS	SIZE
TE2020	Leather straps with grommet reinforced holes	Brown (BR), Black (BL) or Burgundy (BU)	10" x 3" x 9"
TE2022	Same as TE2020 but with 3 inside pockets	Brown (BR), Black (BL) or Burgundy (BU)	10" x 3" x 9"



CANVAS NUT AND BOLT POUCHES

PART #	DESCRIPTION	SIZE
4570B2	9" x 10" with straps & snaps. Available with magnetic strip	9" x 10"
4570M2	With magnetic strip, straps & snaps. Also available in black canvas	9" x 10"
45911M2	Magnetic strip, straps & snaps. Cotter key holders, 1 inside pocket, reinforced sides and bottom	3" x 8" x 9"



TE2000



TE2001



CANVAS NUT & BOLT POUCHES

Both styles are available in yellow vinyl or Blackwrap.

PART #	DESCRIPTION	SIZE
TE2000	Pouch with quick release snap	9" x 4" x 9"
TE2001	Pouch with web straps & snaps	9" x 4" x 9"

CANVAS ZIPPER POUCHES

PART #	SIZE
TE2010	12" x 9"
TE2012	12" x 15"

BODY BELT TOOL HOLSTERS



49261



49261S



42266



42266S

BACK HOLSTERS

To order left handed tool holsters, add "LH" to end of the part number.

PART #	DESCRIPTION	COLORS
49261	4 Pocket double back holster	Natural, Brown (BR), Black (BL) or Burgundy (BU).
49261S	4 Pocket short double back holster	Natural, Brown (BR), Black (BL) or Burgundy (BU)
42266	5 Pocket double back holster	Natural, Brown (BR), Black (BL) or Burgundy (BU)
42266S	5 Pocket short double back holster	Natural, Brown (BR), Black (BL) or Burgundy (BU)



111HLS



111HLSX



111HLDS



42666S

LINEMAN'S HOLSTERS

PART #	DESCRIPTION	COLORS
111HLS	4 Pocket linemen's holster with knife snap	Natural leather with finished back.
111HLSX	4 Pocket linemen's holster with knife snap	Natural black leather with finished back.
111HLDS	5 Pocket linemen's holster with knife snap	Natural leather with finished back
42666S	5 Pocket double back holster with skinning knife pouch	Natural Brown (BR), Black (BL) or Burgundy (BU)



111BWH



111LWH



2402G



4089

WRENCH HOLDERS

PART #	DESCRIPTION
111BWH	Bell wrench holder
111LWH	Lowell wrench holder

HOLSTERS AND CARRIERS

PART #	DESCRIPTION
2402G	Gated handline carrier
4089	Skinning knife holster

WOOD POLE FALL RESTRAINT



490W2



490DRMS



490DWDS



490R



490DWMC

EZ SQUEEZE™

The new lightweight design EZ Squeeze™ offers superb wood pole fall restriction. Equipped with Buckingham's patent pending WebGrab™ and the new BuckHorn adjustment lever, climbers can adjust the strap length with just a flick of the wrist. Its modular design makes it easy to change out any worn or damaged components in the field. With 3,600 lb. rated gate hardware and red warning excessive wear indicators in the straps, the EZ Squeeze is one of the most innovated tools in use today.

PART #	INNER STRAP	OUTER STRAP	BELT CONNECTION
490W2	48" Nylon webbing	36" Neoprene nylon	Locking carabiners
490DRMS	70" Rope	36" Neoprene nylon	Locking snaphooks
490DWDS	48" Nylon webbing	36" Neoprene nylon	Locking snaphooks
490R	70" Rope	36" Neoprene nylon	Locking carabiners
490DWMC	70" Nylon webbing	36" Neoprene nylon	Locking carabiners
490MRMS*	70" Rope	44" Neoprene nylon	Locking snaphooks

* Not shown



EZ SQUEEZE™ RETROFIT KIT

This retrofit kit allows someone using a SuperSqueeze™ with carabiners to easily update their unit to an EZ Squeeze™. The outer strap retrofit kit includes the Web Grab with the Buck Horn, looped handle and instructions.

PART #
488TW2Q3

WOOD POLE FALL RESTRAINT



488R



488RT



488RQ4



488W2



488TW2Q3



488W2Q3

SUPERSQUEEZE™

The lightweight design of the SuperSqueeze™ offers superb wood pole fall restriction. Both the Inner and outer straps can be easily adjusted with one hand using Buckingham's WebGrab™ or BuckGrab™. The SuperSqueeze™ modular design makes it easy to change out worn or damaged components in the field. Only one point to disconnect from the climber's belt point when climbing over an obstruction, it can be used by either right or left handed climbers. All straps have red warning centers and feature a 3,600 lb. gate rated hardware. Meets ASTM F887-II. Rated to 350 lbs.

PART #	INNER STRAP	OUTER STRAP	BELT CONNECTORS	STANDARDS
488W2	48" Nylon webbing	36" Neoprene nylon	Locking carabiners	ASTM F887-11
488W2Q3	48" Nylon webbing	36" Neoprene nylon	Locking snaphooks	ASTM F887-11
488R	70" Rope	36" Neoprene nylon	Locking carabiners	ASTM F887-11
488RQ4	70" Rope	36" Neoprene nylon	Locking snaphooks	ASTM F887-11
488RT	70" Rope	52" Neoprene nylon	Locking carabiners	ASTM F887-11
488TW2Q3	78" Nylon webbing	52" Neoprene nylon	Locking snaphooks	ASTM F887-11

SUPERSQUEEZE™ REPLACEMENT PARTS

PART #	DESCRIPTION
488Q2	Outer strap with out web grab
488	Outer strap with web grab
488R2	Inner rope with buck grab
488R1	Inner rope with out buck grab
5004B	Buck grab rope inner
5005T	Carabiners
5004BW2Q4	Web grab only outer strap
1717	Serrated roto snap

SECONDARY LANYARDS



BUCKADJUSTER

Used as a secondary strap when climbing over obstacles. The length of this 1/2" x 8' rope lanyard is easily adjustable with one hand using the attached length adjusting device.

PART #

9-8



BUCKADJUSTER WITH SUPER FABRIC

A lightweight work positioning strap that features a micro adjuster. A protective sleeve made with Super Fabric is included to protect the rope from excessive wear.

PART #

9A4-8



ADJUSTABLE WEB LANYARD

Adjustable web lanyard that can be used as a second positioning strap to secure a user when climbing over obstacles. Available in 6' and 8' lengths.

PART #

4812Y



ADJUSTABLE WEB LANYARD WITH WEBGRAB

A Secondary web lanyard with the Buck WebGrab™ for easy adjustment and has all the benefits of web combined with the easy adjustment of rope! Designed to use when climber over obstructions. Various lengths are available.

PART #

48129W2Y



SUPERSQUEEZE RESCUE TRAINER

This unique system allows 25' hi-vis orange cut rope to be stowed in bag that is attached to the rescue mannequin. After the rescuer cuts the rope and lowers the mannequin, simply pull additional rope from bag, run it through the BuckGrab™ and tie a stopper knot in the end of the rope.

PART #

488PR



SUPERSQUEEZE™ POLE TOP RESCUE



SuperSqueeze™ Pole Top Rescue features orange web cut strap and locking snap hooks for each connection to the rescue mannequin. Web grab provides easy adjustment for diameter of poles. Extra cut straps available in various lengths of 10', 50', 100' & 150'.

PART #

33709E

POLE CLIMBERS

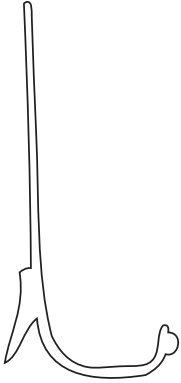
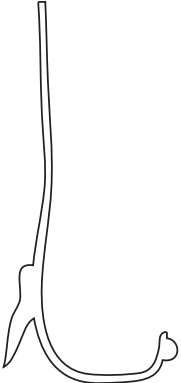
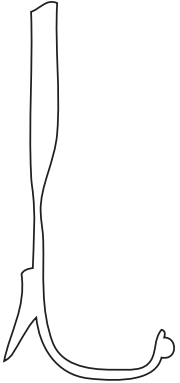
CLIMBER IRON OPTIONS

NON CONTOURED SHANK (PREFIX T)	CONTOURED SHANK (PREFIX TB & SB)	TWISTED SHANK (ADD SUFFIX T)	OFFSET STIRRUP	NARROW STIRRUP
				
<p>Shank is straight from the top of the sleeve to the base of the gaff.</p>	<p>Shank top is straight with an outward curve to accommodate the ankle bone.</p>	<p>Shank follows the contour of the calf muscle to help reduce chafing. Able to be used with metal insert but not recommended.</p>	<p>Stirrup sits in the center of the foot.</p>	<p>Stirrup width of 4" opposed to the standard 4-1/2".</p>



STEEL ALLOY

This offset, fixed gaff climber has a narrower stirrup. It measures 3-3/4". Standard 15-18" top slide adjustment

PART #
BD12L-1N



STEEL

Contoured shank, offset stirrup, permanent gaff, nylon foot straps, and standard length sleeves.

PART #
98479



STEEL

Non-replaceable gaff with an offset design, and a twisted shank. Standard 15-18" top slide adjustment.

PART #
BD12C-1N



STEEL

Contoured shank, straight stirrup, dowel & screw replaceable gaff and nylon foot straps. Includes standard length sleeves.

PART #
SB92089A

POLE CLIMBERS



STEEL

Contoured shank, offset stirrup, dowel & screw replaceable gaff, nylon foot straps. Includes standard length sleeves.

PART #
SB94089A



STEEL

15"-18" standard top slide length, replaceable gaff, offset design, Includes #2 gaff guard and #5 gaff gauge.

PART #
BD16B-1N



STEEL ALLOY

Replaceable gaff, twisted shank and offset design. #2 gaff guard and a #5 gaff gauge included.

PART #
BD16BC-1N



ALUMINUM ALLOY

Contour shank with an offset design and replaceable gaff. #2 gaff guard and #5 gaff gauge standard.

PART #
BD14-1N



ALUMINUM

Non contoured, offset replaceable gaff, with beveled stirrup. Rated to 350 lbs. Exceeds ASTM F887. See page 122 for pads.

PART #
A94089A



TITANIUM

Contoured shank, straight stirrup with bevel, screw style replaceable gaff, nylon foot straps, and standard length sleeves.

PART #
T92089A



TITANIUM

Contoured shank, straight stirrup, permanent gaff, nylon foot straps, and includes standard length sleeves.

PART #
TB96469



TITANIUM

Features contoured shank, offset stirrup permanent gaff, nylon foot straps, and standard length sleeves.

PART #
TB98479



TITANIUM

Features non contoured shank, beveled offset stirrup, dowel & screw replaceable gaff, nylon foot straps, and standard length sleeves.

PART #
T94089A



TITANIUM

Features contoured shank, straight stirrup, dowel & screw replaceable gaff, nylon foot straps and standard length sleeves.

PART #
TB92089A



TITANIUM

Features a contoured shank, offset stirrup, dowel & screw replaceable gaff and nylon foot straps, and standard length sleeves.

PART #
TB94089A

POLE CLIMBER PADS



POLE CLIMBER PADS

PART #	DESCRIPTION
130D	"L" climber pad with loops
140D	"Wing" climber pad with shank tunnel
150T	"T" climber pad with loops



105A



105BC

CURVED PADS WITH STEEL INSERTS

PART #	STYLE
105A	Straight BD12 & BD16 styles
105AC	Angled BD12 & BD16 styles
105B	Straight for BD14 styles
105BC	Angled for BD14 styles



Add "S" to the part number for padding.

145 SERIES CLIMBER PADS

Big on comfort and climber control. This field proven, double strap design results in an extremely comfortable pad with tremendous climber support.

PART #	STYLE
145AC	For BD12 - BD16 climbers
145BC	For BD14 climbers



CLIMBER PADS

The 145 CVW combines hook and loop strap with the climber control of the 105 series pads and the comfort of the 145 series pads.

PART #	STYLE
145BCVW	Aluminum
145ACVW	Steel



CLIMBER PADS

These pads are made with rugged woven nylon material and have a cinch type hook and loop closure for extra security. The angle metal insert provides additional climber control.

PART #	CLIMBER STYLE
145BCV	Aluminum
145ACV	Steel



CLIMBER PADS

The 145 Hook n' Loop pads are made with rugged woven nylon material and have a cinch type hook and loop closure. The angled metal insert provides additional climber control. Please order the pad according to the climber.

PART #
150V

POLE CLIMBER PADS



350321

"C" WRAP CLIMBER PADS

PART #	DESCRIPTION
350321	Angled BuckAlloy™ aluminum 'C' pad
35032KL	Klein compatible "C" pad



3124



3126

CLIMBER PADS

PART #	DESCRIPTION
3124	Leather "T" pad with 3/4" padding
3126	Leather "L" pad with extra padding



BIG BUCK CLIMBER PADS

Fits 1" and 1-1/4" straps, to secure the pad to the calf resulting in superior support of the leg. An angled metal insert prevents the climber shank from shifting on the calf and the thick felt padding adds to the overall comfort. 2 pair of straps included.

PART #	DESCRIPTION
3118	For Standard Climbers



CLIMBER PAD LEG PROTECTOR

Hook and loop leg protector mounts directly to the leg and underneath a standard climber pad. 1/4" of padding protects the calf from the climber shank. One size fits all.

PART #	SIZE
3119	10" H x 8-1/2" W



3500



3500C



3503



3503C

CUSHION WRAP PADS

PART #	DESCRIPTION	WIDTH	PADDING
3500	Hook and loop pad	4"	3/4"
3500C	Hook and loop pad with cinch loop	4"	3/4"
3503	Hook and loop pad that features a continuous wrap	3"	3/4"
3503C	Hook and loop pad that features a cinch loop	3"	3/4"

POLE CLIMBER ACCESSORIES



CLIMBER GUARDS

Used for protection against accidental brush contact of a conductor. Furnished uncut to accommodate any length of climber.

PART #
CG-1



FOOT PLATES

Attaches to any steel climber for maximum support and comfort. Not for use with aluminum climbers.

PART #
35033



CLIMBER SHIELD

Ideal for apprentices, this lightweight shield helps prevent gaff puncture wounds. Attaches easily to the shank and has a slot for the foot strap.

PART #
10

BASHLIN CLIMBER STRAPS WITH BUCKLE PADS

PART #	SIZE	DESCRIPTION
85N	1" x 24"	Hook and loop foot strap
86N	1" x 28"	Single piece nylon leg strap
89N	1" x 28"	2 Piece nylon foot strap



Single piece leg strap



Two piece foot strap

BUCKINGHAM CLIMBER STRAPS

Hook and loop climber straps are Bucks newest addition to foot straps. These easy on and easy off Velcro straps are great for Rodeo participants! Manufactured from soft, pliable 1-3/4" nylon, offers added comfort to the top and back of the foot. Provides a fast and easy attachment while providing the user an extra tight fit. Overall length 29".

PART #	SIZE	DESCRIPTION
21401C	1-3/4" x 28"	Hook and loop foot strap



POLE CLIMBER ACCESSORIES



2239



2634



263432



2639



2644



2649



2839



3049



21341



21391

BUCKINGHAM SINGLE PIECE CLIMBER STRAPS

PART #	SIZE	DESCRIPTION
2239	1" x 22"	Nylon foot strap
2634	1" x 26"	Latigo leather foot strap
263432	1" x 30"	Latigo leather foot strap
2639	1" x 24"	Latigo leather foot strap
2644	1" x 26"	Latigo leather foot strap with buckle pad
2649	1" x 26"	Nylon foot strap with buckle pad
2839	1" x 28"	Nylon foot strap
3049	1" x 30"	Nylon foot strap with buckle pad

BUCKINGHAM TWO PIECE CLIMBER STRAPS

21341	1" x 26"	Two piece latigo leather foot strap with split ring and tongue buckle chafe
21391	1" x 26"	Two piece nylon foot strap with split rings
A21391	1" x 26"	Two piece nylon foot strap with split rings for BuckAlloy™ Aluminum Climber



996



9215



A9215

CLIMBER SLEEVE FASTENERS

PART #	DESCRIPTION
996	Climbers with threaded sleeve attachment holes
9215	Climbers with smooth sleeve attachment holes
A9215	BuckAlloy™ aluminum climber sleeves



9202



9204

CLIMBER SLEEVES

Chrome colored sleeves for standard length climbers.

PART #	DESCRIPTION
9202	Long sleeve, adjust from 19-1/4" to 21-3/4"
9204	Short sleeve, adjust from 14-1/4" to 17-1/4"
A9204	Buckyard sleeve, adjust from 14-1/4" to 17-1/4"

POLE CLIMBER ACCESSORIES



2



1972G



60094



6909M2



6909U

GAFF GUARDS

PART #	STYLE
2	Leather gaff guard with hook and loop strap, sold in pairs
1972G	Snap-on gaff guard, sold in pairs
60094	Leather gaff guards with hook and loop strap fasteners
6909M2	A strong magnet that securely attaches to all manufacturers pole and tree gaffs
6909U	Plastic coated clip-on for permanent or replaceable gaffs. Fits all brands of climbers



Pin Style



Screw Style



BUCKINGHAM REPLACEMENT GAFFS

PART #	SIZE	STYLE
A9106A	1-5/8"	16° CCA Pole gaff, Buck Alloy
A9306A	1-3/4"	16° Pole gaffs, Buck Alloy
T9106A	1-5/8"	16° CCA Pole gaffs, screw style, December 2010 & before
T9206A	1-3/4"	16° Pole gaffs, screw style, December 2010 & before
NB9106A	1-3/4"	16° CCA Pole gaffs, screw style, January 2011 & after
NB9206A	1-3/4"	16° Pole gaffs, screw style, January 2011 & after



14P



14T



14

BASHLIN REPLACEMENT GAFFS

PART #	STYLE
14	Standard 1-5/8" gaffs
14P	Polished 1-5/8" gaffs
14T	2-1/2" Tree gaffs



POLE GAFF MAINTENANCE KIT

PART #	DESCRIPTION
6025	Gaff maintenance kit for standard & CCA gaffs

FOOTWEAR

DIELECTRIC DEEP HEEL RUBBER BOOTS & OVERSHOES

Tested at 20,000 V and made of waterproof, ozone resistant rubber. Anti-skid out soles provide extra safety when climbing ladders and poles where the deep heel cavity can lock onto the rungs. Yellow/Black boots are lot tested, Red/Black boots are 100% tested.



21402



51581



51530



31924

YELLOW & BLACK DIELECTRIC

PART #	STYLE	WHOLE SIZES ONLY	WHOLE & HALF SIZES
51581	Slip-on overshoe	5, 6, 13 - 17	7 - 12
51530	2 Buckle overshoe	6 - 17	--
21402	17" Slip-on boot	7 - 17	--
31924	4 Buckle boot	6 - 17	--



51508



21405



51509

RED & BLACK DIELECTRIC

PART #	STYLE	WHOLE SIZES ONLY
51508	Slip-on overshoe	7 - 17
51509	2 Buckle overshoe	7 - 17
21405	17" Slip-on boot	7 - 17

YAKTRAX PRO

Spikeless, ultra lightweight design with skid lock coil system. Designed with durable natural rubber outerband for flexible fit and abrasion resistant steel coils. Removable strap and heel tab ensures secure fit with easy installation and removal.

PART #	COLOR	SIZE	MEN'S	WOMEN'S
YT08609	Black	S	5 - 8-1/2	6-1/2 - 10
YT08611	Black	M	9 - 11	10-1/2 - 12-1/2
YT08613	Black	L	11-1/2 - 13-1/2	13 - 15
YT08615	Black	XL	14 +	15-1/2 +



STABILicers

The 34 case-hardened replaceable cleats per pair provide positive traction in snow and ice. Fully adjustable to fit virtually any boot with an easy on & off strap system.

PART #	SIZE	MEN'S	WOMEN'S
TE32I - S	S	6-1/2 - 7-1/2	8-1/2 - 10
TE32I - M	M	8 - 10	11 and Up
TE32I - L	L	10-1/2 - 12	--
TE32I - XL	XL	12-1/2 - 14	--
TE32I - XXL	XXL	15 - 16	--



STABILicers LITE

Multi-directional cleats for light-duty traction. Strong rubber straps holds the sole securely in place.

PART #	SIZE	MEN'S	WOMEN'S
TE32L-S	S	4 - 7	5 - 8
TE32L-M	M	7-1/2 - 10	8-1/2 - 12
TE32L-L	L	10-1/2 - 13	--
TE32L-XL	XL	13-1/2 - 16	--



STABILicers OVERSHOE

Provides great waterproof traction in snow or icy conditions. Extra large gusset opening allows for easy on and off.

PART #	SIZE	MEN'S	WOMEN'S
TE32O-S	S	5-1/2 - 7	7 - 8-1/2
TE32O-M	M	7-1/2 - 9	9 - 10-1/2
TE32O-L	L	9-1/2 - 11	11 - 12-1/2
TE32O-XL	XL	11-1/2 - 13	13 - 14-1/2
TE32O-XXL	XXL	13-1/2 - 15	--



ARC RESISTANT RAIN GEAR

All jackets and coats have a 3 piece hood-in-collar, two pockets with Velcro® closure, non-conductive zipper with dual flies & snaps, Nomex® ventilation system, fall protection access, Velcro® tab type wrist adjusters and 3M 2" reflective trim around chest, over the shoulders, around the biceps and around the hood. Bib trousers have a quick release suspender system, fly front with snap, Velcro® tab type cuff adjusters and 3M 2" reflective trim around the calves and knees. Pants have a elastic waist, fly front with snap, Velcro® tab type cuff adjusters and 3M 2" reflective trim around the calves and knees. Other styles available.



International Orange



Yellow



Fluorescent Lime Yellow



Fluorescent Orange

SERIES 1000 ARCLITE SUITS

These suits are made of the same material and offer the same protection as the 1500 series without the Hi-Visibilty rating.

- Made of 8 oz./yd2 Nomex® E89/Synthetic Leather PU/PVC
- Electric Arc Rated per ASTM F1891 & NFPA 70E
- Available in Yellow or International Orange

SERIES 1500 HI-VIS ARCLITE SUITS

Arc & flame resistant, these suits do not melt, drip, ignite or break open. Suits are waterproof, lightweight and flexible.

- Made of 8 oz./yd2 Nomex® E89/Synthetic Leather PU/PVC
- Electric Arc Rated per ASTM F1891 & NFPA 70E
- High Visibility Rated per ANSI 107 Class 3 Level 2
- Available in Fluorescent Lime Yellow or Fluorescent Orange

PART #	GARMENT
1103J	Waist length jacket
1101T	Bib trousers
1101P	Elastic waist pants
1103C	48" Length coat

PART #	GARMENT
1503J	Waist length jacket
1501T	Bib trousers
1501P	Elastic waist pants
1503C	48" Length coat

ARC JACKET • COAT • BIB • PANTS SIZING MATRIX

Add 2" for long sizes. Add 4" for tall sizes. Standard inseam on bibs and trousers is 30".

	S	M	L	XL	2XL	3XL
Sleeve Length	34"	34-1/2"	35"	36"	36"	37"
Body Length	30"	30"	30"	30"	31"	31"
Chest Size	36" - 38"	40" - 42"	44" - 46"	48" - 50"	52" - 54"	56" - 58"
Waist Size	32" - 34"	36" - 38"	40" - 42"	44" - 46"	48" - 50"	52" - 54"

ARC RESISTANT RAIN GEAR

Polyurethane FR/ARC rated rain wear garments specifications and certifications:

Made of 10 oz./yd² Polyurethane over FR cotton knit, High visibility rated per ANSI 107, Arc Rating: 16.3 Cal/cm², Electric arc rated per ASTM F1891, Flash fire rated per ASTM F2733, Chemical penetration rated per ASTM F903,



Hood



Collar Storage



Vented Back



Quick Release Clip



Lanyard Opening



Cargo Pocket



Raglan Sleeve



Leg Zippers



ARC RATED JACKET

Features hook and loop adjustable cuffs, vented back, dee ring access, internal anti-wicking dam, hand warmer pockets, and angled bar-tacks on pockets and flaps for additional support in heavily stressed areas.

PART #

AJPU10LY

ARC RATED BIB OVERALL

These overalls feature quick release suspenders, 2-snap fly closure, right thigh pocket, anti-wicking cuffs, and a diamond reinforced patch (DRP) to prevent crotch "blow outs".

PART #

ABPU10LYZ

AJPU10LY JACKET SIZING MATRIX

SIZE	CHEST SIZE	SLEEVE LENGTH	JACKET LENGTH
S	36" - 38"	33"	29"
M	40" - 42"	33-1/2"	29"
L	44" - 46"	34"	29"
XL	48" - 50"	34-1/2"	29"
XXL	52" - 54"	35"	29"
XXXL	56" - 58"	36-1/2"	29"

ABPU10LY JACKET SIZING MATRIX

SIZE	CHEST SIZE	SLEEVE LENGTH	JACKET LENGTH
S	36" - 38"	33"	29"
M	40" - 42"	33-1/2"	29"
L	44" - 46"	34"	29"
XL	48" - 50"	34-1/2"	29"
XXL	52" - 54"	35"	29"
XXXL	56" - 58"	36-1/2"	29"

WORK GLOVES



04-3500-70



08-3083-10



11-3280-60



05-3080-70



11-3245-60



12-3180-70

PERFORMANCE WORK GLOVES

Please specify size when ordering.

FEATURES	PART #					
	04-3500-70	05-3080-70	08-3083-10	11-3245-60	11-3280-60	12-3180-70
Arc Rated				✓	✓	
Flame Resistant					✓	
Heavy-Duty	✓	✓	✓		✓	✓
High Visibility			✓			
Kevlar® Lined		✓	✓		✓	
Non - Slip Grip	✓	✓	✓			
Safety Cuff	✓			✓	✓	
Size	S - 2XL	S - 3XL	S - 2XL	S - 2XL	S - 2XL	S - 2XL



TEDG



TEFG



TELG45



TELM



825

LINEMAN'S LEATHER GLOVES

PART #	SIZES	DESCRIPTION
TEDG	S - XL	Heavy weight buckskin drivers gloves
TEFG	9 - 12	Buckskin foreman's gloves for light duty wear. 10" Overall length with open cuff
TELG45	8 - 13	Buckskin lineman's gloves with 4-1/2" gauntlet
TELM	9 - 12	Buckskin one-finger work mitten provides extra warmth in cold weather
825	One size	One-finger wool liners provide the maximum in comfort and warmth. One size fits all

RUBBER INSULATING GLOVES

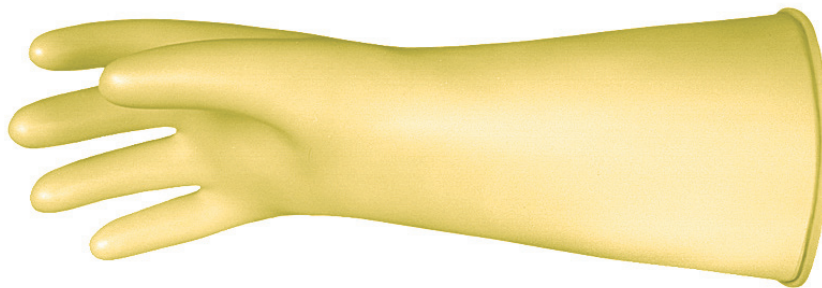

LOW VOLTAGE RUBBER GLOVES

Class 0 and 00 gloves are available in 11" and 14" lengths and in full and half sizes 8 through 12. Extremely flexible, these gloves provide the dexterity needed when working with small parts. Meets ASTM D120 standards.

PART #	CLASS	LENGTH	COLOR	MAXIMUM USE VOLTAGE
E0011R	00	11"	Red	500 VAC
E011Y	0	11"	Yellow	1,000 VAC
E014Y	0	14"	Yellow	1,000 VAC

Class 0 gloves are also available in red, black, or 2-color.
Class 00 gloves are also available in blue, or 2-color Type II rubber.



Bell Cuff



Straight Cuff



Contour Cuff



Mitten

HIGH VOLTAGE RUBBER GLOVES

Class 1 through 4 gloves are available in 14", 16", and 18" lengths. The Bell Cuff allows for heavier winter clothes and greater air flow in warmer weather. The Contour Cuff is angled to prevent bunching or binding at the elbow when the arm is bent. All meet ASTM D120.

CLASS	LENGTH	CUFF STYLE	COLOR	MAX USE VOLTAGE
1	14", 16" or 18"	BC, CC	B, YB or RB	7,500 VAC
2	14", 16" or 18"	BC, CC	B, YB or RB	17,000 VAC
3	14", 16" or 18"	BC, CC	B, YB or RB	26,500 VAC
4	14", 16" or 18"	BC, CC	B, YB or RB	36,000 VAC

Color: "B" = black, "YB" = yellow inside/black outside, "RB" = red inside/black outside.

Cuff style: straight cuff is standard. "BC" = bell cuff, "CC" = contour cuff 18" only.

Sizing: straight, bell & contour full & half sizes 8 - 12. Class 3 & 4 full & half 9 - 12.

1 finger mittens: use "EM" prefix. Full sizes only 9 - 11.

RUBBER GLOVE ACCESSORIES

Maintain a distance of 1" between the cuff of the protector and the cuff of the rubber glove for every 10,000 volts rating.
 Examples: For a 14" class 2 rubber glove, order a 12" protector, For a 18" class 4 rubber glove order a 14" protector.

LEATHER PROTECTOR GLOVES & MITTENS

For use with Class 1-4 Rubber Insulated Gloves.
 Exceeds all ASTM F-696 leather protector glove standards.
 Available in sizes 8-8.5, 9-9.5, 10-10.5, 11-11.5 & 12-12.5

PART #	DESCRIPTION
TPG-010-SIZE	10" Gloves
TPG-012-SIZE	12" Gloves
TPG-014-SIZE	14" Gloves
TPG-016-SIZE	16" Gloves
TPG-012M-SIZE	12" Mittens
TPG-014M-SIZE	14" Mittens
TPG-016M-SIZE	16" Mittens



TPG-014

TPG-014M

Order a half size larger than your rubber glove size.
 Example: If your rubber glove size is 9 order 9-9.5
 if your glove size is 10.5 order size 11-11.5

LEATHER PROTECTORS FOR RUBBER GLOVES

Leather protectors provide mechanical protection against cuts, snags or any damage that may compromise the insulating integrity of the rubber gloves.

Add "1F" suffix for 1-finger mitten protectors.

Add "BC" suffix for bell cuff protectors.

Many other styles and materials are available.

PART #	DESCRIPTION	MATERIAL
999	10-1/2" Low-voltage protector	Goatskin
1057-3	12" High-voltage protector	Cowhide
1057-5	14" High-voltage protector	Cowhide



999

1057-5



G-99

GLOVE INFLATOR

Portable and easy to use.

This unit allows for field inspection of rubber gloves.

PART #	DESCRIPTION
G-99	Glove inflator kit
G-100	Kit includes adapter for low voltage gloves



COTTON GLOVE LINERS

PART #
TEGL



GLOVE POWDER

Case of 12, 6 oz. bottles.

PART #
10-4



MOLDED RUBBER SLEEVES

Molded sleeves are manufactured by either injection or compression molding. The advantage of these methods is the ability to produce sleeves made of Type I natural rubber or Type II synthetic rubber. Synthetic rubber has the added benefit of being resistant to ozone and ultraviolet radiation. Meets ASTM D1051. Colors: B = black, Y = yellow, M = maroon, O = orange. Type II sleeves available in class 1 & 2 only, black or orange.

CLASS	SIZE	COLOR	MAX USE VOLTAGE
1	R or L	B or Y	7,500 VAC
2	R, L or XL	B, Y or M	17,000 VAC
3	R or L	Y or M	26,500 VAC
4	R or L	M	36,000 VAC

To order start with the class, then size, and color.
Example: a pair of class 2, regular, yellow sleeves, would be PART # 2RY.



Straight

Extra-curved

DIPPED RUBBER SLEEVES

Dipped sleeves are manufactured in the same way as rubber insulating gloves. Porcelain forms are dipped into liquefied rubber, dried, trimmed, marked and cured. These are the most comfortable and flexible sleeves available. Meets ASTM D1051. Colors: B = black, Y = yellow, Y/B = yellow/black, R/B = red/black. Add "ST" suffix for straight cuff or "EC" suffix for extra-curved

CLASS	SIZE	COLOR	MAX USE VOLTAGE
0	R, L or XL	YLW	1,000 VAC
1	R, L or XL	B, Y, Y/B or R/B	7,500 VAC
2	R, L or XL	B, Y, Y/B or R/B	17,000 VAC
3	R, L or XL	B, Y, Y/B or R/B	26,500 VAC
4	R, L or XL	B, Y, Y/B or R/B	36,000 VAC

To order: Start with a "D" prefix, then class, size, and color.
Example: a pair of class 3, large, red & black sleeves, would be PART # D3LRB.



SLEEVE HARNESS

PART #
H-1



SLEEVE BUTTONS

2-piece screw type, set of 4.

PART #
TEB-22



SLEEVE STRAP

PART #
S-1

GLOVE & SLEEVE BAGS



LOW-VOLTAGE GLOVE BAG

12" overall length.

PART #
TE2028



HI-VOLTAGE GLOVE BAG

19" overall length.

PART #
TE2030



GLOVE & SLEEVE BAG

19" overall length.

PART #
TE2035



FULL LENGTH SLEEVE BAG

28" overall length.

PART #
TE2040



COMBINATION SLEEVE & GLOVE BAG

30" overall length.

PART #
TE2044



BLACKWRAP SLEEVE & GLOVE BAG

30" overall length.

PART #
TE2046

RUBBER INSULATING BLANKETS

Rubber blankets come in a variety of classes, styles and sizes. Made of either Type I natural rubber or Type II synthetic rubber, these blankets can be used anywhere that standard cover-up devices cannot. All blankets meet current ASTM D1048 specifications.

SOLID STYLE BLANKETS

PART #	CLASS	SIZE	COLOR	TYPE	MAX USE VOLTAGE
12	2	22" x 22"	Black	I	17,000 VAC
13	4	22" x 22"	Orange	II	36,000 VAC
400E	2	27" x 36"	Black	I	17,000 VAC
300E	2	36" x 36"	Black	I	17,000 VAC
901E	4	36" x 36"	Black	II	36,000 VAC
900E	4	36" x 36"	Orange	II	36,000 VAC



SLOTTED STYLE BLANKETS

PART #	CLASS	SIZE	COLOR	TYPE	MAX USE VOLTAGE
14	2	22" x 22"	Black	I	17,000 VAC
1100	2	36" x 36"	Black	I	17,000 VAC
15	4	22" x 22"	Orange	II	36,000 VAC
15-1	4	22" x 22"	Black	II	36,000 VAC
1300	4	36" x 36"	Orange	II	36,000 VAC
1301	4	36" x 36"	Black	II	36,000 VAC



LOW VOLTAGE BLANKETS

"Zip" style blankets have a 1" wide strips of hook & pile closures.

PART #	CLASS	SIZE	STYLE	TYPE	MAX USE VOLTAGE
1212YLV	0	12" x 12"	Zip	II	1,000 VAC
1212YLVNV	0	12" x 12"	Plain	II	1,000 VAC
1818YLV	0	18" x 18"	Zip	II	1,000 VAC
1818YLVNV	0	18" x 18"	Plain	II	1,000 VAC
1836YLV	0	18" x 36"	Zip	II	1,000 VAC
1836YLVNV	0	18" x 36"	Plain	II	1,000 VAC
3636YLV	0	36" x 36"	Zip	II	1,000 VAC
3636YLVNV	0	36" x 36"	Plain	II	1,000 VAC

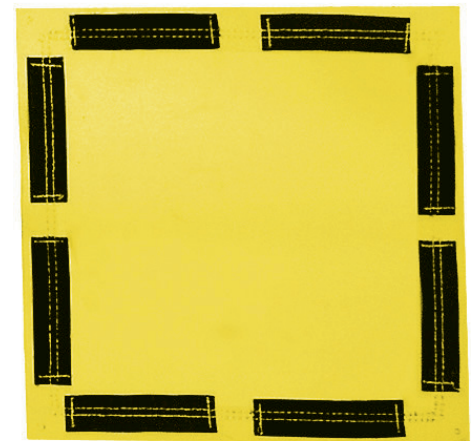

"Zip" Style Shown

RUBBER BLANKET ACCESSORIES



**NYLON
BLANKET CLAMP**

PART #
DNBC-1



**NYLON BLANKET CLAMP
WITH SHOTGUN RINGS**

PART #
DNBC-1HS



**MAGNETIC
BLANKET BUTTON**

PART #
MB-6



BLANKET CANISTER WITH HANDLE
10" x 37" holds 6 each 36" blankets.

PART #
SBC-6



BLANKET CANISTER WITH NO HANDLE
7" x 37" holds 4 each 36" blankets.

PART #
P-4



3' X 30' PVC SHEETING ROLL

Used to protect personnel working on or near energized conductors and equipment, this 40 mil thick insulating material can be easily cut to any size needed for the job.

PART #	CLASS	MAX USE	COLOR
RLB0	0	1,000 Volts	Yellow
RLBPVC1	1	7,500 Volts	Clear



BLANKET STRAP

PART #	LENGTH
TY-14	14"
TY-30	30"

INSULATING LINE HOSE & COVER-UP EQUIPMENT

The self-locking lip prevents the line hose from coming off the conductor after the installation is complete yet is easy for a lineman to assemble and take apart. Made of Type II synthetic rubber, this line hose stays flexible even in cold weather and is not damaged by ozone or ultraviolet rays. Meets ASTM D1050.



Connector End Line Hose



Straight Line Hose

LINE HOSE

PART #	CLASS	SIZE	STYLE	MAX USE VOLTAGE
OR125-45	2	1-1/4" x 4-1/2'	Straight	17,000 VAC
OR125-45C	2	1-1/4" x 4-1/2'	Connector	17,000 VAC
OR125-6	2	1-1/4" x 6'	Straight	17,000 VAC
OR125-6C	2	1-1/4" x 6'	Connector	17,000 VAC
OR150-45	3	1-1/2" x 4-1/2'	Straight	26,500 VAC
OR150-45C	3	1-1/2" x 4-1/2'	Connector	26,500 VAC
OR150-6	3	1-1/2" x 6'	Straight	26,500 VAC
OR150-6C	3	1-1/2" x 6'	Connector	26,500 VAC



EXTENDED LIP LINE HOSE

PART #	CLASS	SIZE	STYLE	MAX USE VOLTAGE
SU150-45	4	1-1/2" x 4-1/2'	Straight	36,000 VAC
SU150-45C	4	1-1/2" x 4-1/2'	Connector	36,000 VAC
SU150-6	4	1-1/2" x 6'	Straight	36,000 VAC
SU150-6C	4	1-1/2" x 6'	Connector	36,000 VAC



OJRG



OKRG



INSULATOR HOODS

PART #	CLASS	LINE HOSE SIZE	INSULATOR CLASS
OFRG	2	1"	55-1/2/3
OJRG	2	1"	55-4
OKRG	3	1-1/4" to 1-1/2"	55-5

CUTOUT COVERS

PART #	CLASS	OVERALL DIMENSIONS
CC24	2	24" x 15" x 3-1/2"
CC30	4	30" x 20" x 7"

COVER-UP EQUIPMENT



C406-0182

25kV insulator covers are 21" long and 8-1/2" wide. Available with or without Grip-All adapter.



C406-0009

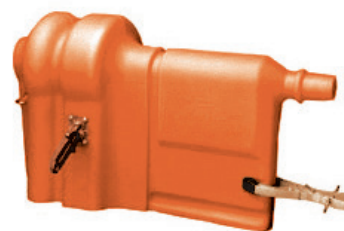

C406-0164



C406-0181GA

These 5' interlocking covers provide extra protection when gloving or sticking. Available with a Grip-All adapter for hot stick application, without adapter for rubber glove application or with a 4' Epoxiglas® handle.

25KV CONDUCTOR AND INSULATOR COVERS

PART #	DESCRIPTION
C406-0181	Conductor cover with 4' epoxiglas handle
P406-0184	Conductor cover without handle or adapter
C406-0181GA	Conductor cover with Grip-All adapter
C406-0182	Insulator cover 6" tall with Grip-All adapter
P406-0185	Insulator cover 6" tall without Grip-All adapter
C406-0182L	Insulator cover 9" tall with Grip-All adapter
P406-0186	Insulator cover 9" tall without Grip-All adapter
C406-0009	Cutout cover
C406-0164	Deadend cover



C406-0557L



C406-0514GA

C406-0557

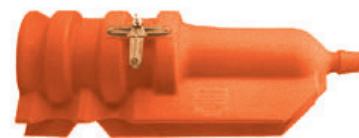

C406-0537

36.6KV CONDUCTOR AND INSULATOR COVERS

Insulator covers for 6-1/2" to 9" diameter pin or post insulators come in two heights: 12" (C406-0557) and 16 1/2" (C406-0557L) and couple with 5 ft.-long line cover (C406-0514GA). Upper ribs in the line cover maintain an air gap between it and the conductor.

PART #	DESCRIPTION
C406-0514GA	Conductor cover with Grip-All adapter
C406-0557	Insulator cover 12" tall with Grip-All adapter
C406-0557L	Insulator cover 16-1/2" tall with Grip-All adapter
C406-0537	Deadend cover with Grip-All adapter

To meet the Class 4 rating, the deadend cover must be used in conjunction with a rubber insulating blanket covering the coupler to the line cover. Failure to use a blanket to cover the coupler may result in electrical shock, severe injury or death by electrocution.

COVER-UP EQUIPMENT

36.6KV & 46KV CONDUCTOR COVERS

Spiral conductor covers are 7" in diameter and 53" in length and are available with a Grip-All adapter, or a 4' or 6' epoxiglas handle. 15/36.6kV covers are formed to fit over most 15kV insulators. Double crossarm units will fit over two 15kV pin-type insulators. All styles are interlocking.

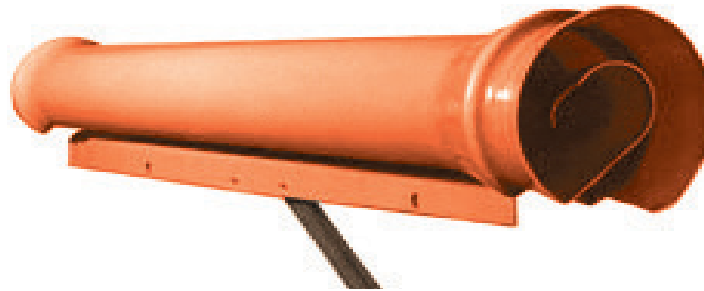

46KV PHASE-TO-PHASE COVERS

PART #	DESCRIPTION
C406-0082	4' Epoxiglas handle
C406-0082-6	6' Epoxiglas handle
C406-0082GA	Grip-all adapter

15/36.6KV PHASE-TO-PHASE COVERS FOR SINGLE CROSSARMS

PART #	DESCRIPTION
C406-0083	4' Epoxiglas handle
C406-0083-6	6' Epoxiglas handle
C406-0083GA	Grip-all adapter

15/36.6KV PHASE-TO-PHASE COVERS FOR DOUBLE CROSSARMS

PART #	DESCRIPTION
C406-0084	4' Epoxiglas handle
C406-0084-6	6' Epoxiglas handle
C406-0084GA	Grip-all adapter



36.6KV CROSSARM COVER

This cover helps prevent tie wires from contacting the crossarm when tying and untying insulators. Designed for single or double-arm construction with slots for double-arming bolts.

PART #
M4933



46KV CONDUCTOR COVER

At 5' in length, these covers come with a Grip-All adapter and can accommodate conductors up to 2" in diameter.

PART #
M4931



46KV INSULATOR COVER

Fits over insulators up to 10-1/2" in diameter and locks with a conductor cover on each end. Adjustable in length form 22" to 34".

PART #
C406-0046

COVER-UP EQUIPMENT

POLE COVERS

The pole covers are ribbed to reduce contact with the pole in order to minimize creosote contamination. Buttons on the 4' and 6' lengths allow the covers to be joined together when longer lengths are needed.

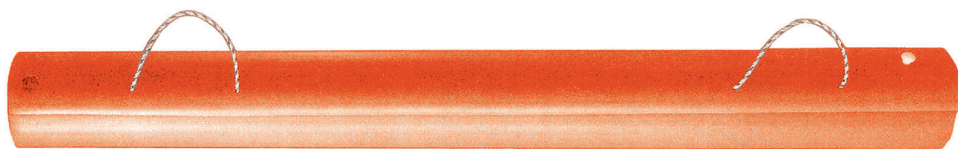

6" DIAMETER POLE COVERS

PART #	DESCRIPTION
C406-0550	48" Overall length
C406-0551	72" Overall length

9" DIAMETER POLE GUARDS

PART #	DESCRIPTION
M4937-1	12" Overall length
M4937-2	24" Overall length
M4937-4	48" Overall length
M4937-6	72" Overall length

12" DIAMETER POLE GUARDS

PART #	DESCRIPTION
C406-0029	24" Overall length
C406-0030	48" Overall length
C406-0000	72" Overall length

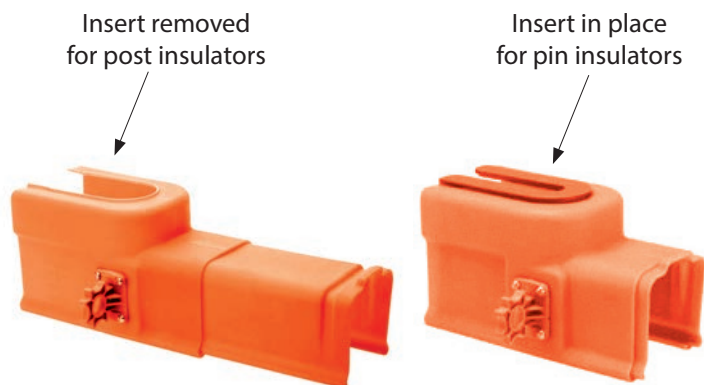

CROSSARM COVER

This rigid cover up fits onto wood or steel crossarm sizes up to 3-3/4" x 4-3/4". It telescopes from 13.1" to 20.9" and is rated at 26.4kV phase-to-phase.

PART #
C406-0504



ROPE LOCK

Helps keep pole covers in place especially on smooth surfaces. Can be used on all sizes of pole guards.

PART #
C406-0547

COVER-UP EQUIPMENT



6060



6065

15KV & 25KV POLYETHYLENE LINE GUARDS

Made of lightweight polyethylene, these guards are available in 5' and 6' lengths. Snap together feature with male & female connecting ends.

PART #	DESCRIPTION
6050	5' Line guard, 15kV
6060	6' Line guard, 15kV
6055	5' Line guard, 25kV
6065	6' Line guard, 25kV



12528



12527



12936

15/25KV CONDUCTOR AND INSULATOR COVERS

These 4'-6" guards are equipped with an adjustable eye for installation with any shotgun. Male and female ends allow the guards to interlock with each other.

PART #	DESCRIPTION
12936	4' 6" Line guard with shotgun eye
12528	Insulator hood for single pins
12527	Insulator hoods for double pins



9144

35KV, 46KV & 69KV CONDUCTOR COVERS

Insulator hoods for either single or double pins. PART # 9770 is adjustable to 3 lengths, 27", 32" and 37".

PART #	DESCRIPTION
9144	22" Insulator hood for single pins
9770	Adjustable insulator hood for double pins

Insulator hood voltage ratings:
 35kV when used with 6010 or 6011 guards.
 46kV when used with 6012 or 6013 guards.
 69kV when used with 12000 or 12001 guards.



6010

35KV, 46KV & 69KV INSULATOR COVERS

These line guards come with either a shotgun eye or an installing stick handle. With interlocking male & female ends, they can also be nested to save on storage space.

PART #	DESCRIPTION
6010	35kV Line guard with shotgun eye
6011	35kV Line guard with 4' Installing stick
6012	46kV Line guard with shotgun eye
6013	46kV Line guard with 4' Installing stick
12000	69kV Line guard with shotgun eye
12001	69kV Line guard with 6' installing stick



POLYETHYLENE SHEETING

This bright orange polyethylene material comes in 4' x 6' sheets and can be cut to smaller sizes with any hand or power saw use to cut wood. It can also be formed with a blow torch or in an oven heated to 250° F.

PART #	DESCRIPTION
C406-0002	Substation & underground barriers



ARC SUPPRESSION BLANKETS

When draped or loosely wrapped over a defective cable or splice, this arc suppression blanket provides protection against electrical arcs and flashes. With Velcro® straps to help keep it in position, this arc suppression blanket has been tested successfully at 42,000 amps fault current.

PART #	SIZE	WEIGHT
C406-0452	4' x 5'	4 lbs.
C406-0453	4' x 8'	6.5 lbs.

This blanket is not classified as "electrically insulated".



PVC SHEETING

Used to protect personnel working on or near energized conductors and equipment, this 40 mil thick insulating material can easily be cut to any size needed for the job. Rolls are 3' x 30'.

PART #	CLASS	MAX USE	COLOR
RLB0	0	1,000 Volts	Yellow
RLBPVC1	1	7,500 Volts	Clear

TRAFFIC & WORK ZONE SAFETY

All signs are MUTCD and NCHRP-350 compliant. Super Bright™ signs are available in Orange, Yellow, White, Fluorescent Lime or Fluorescent Pink. Diamond Grade signs are available in Orange or White. Many other styles are available.



Shown above are some of the most commonly requested signs. Many other legends are available and custom signs can be made to your specifications. All are available in 36" or 48" square made from reflective or non-reflective materials.

STANDARD ROLL-UP SIGNS

These signs are made of heavy duty vinyl. Both ends of the vertical brace are permanently attached to the sign panel. Both ends of the horizontal brace can be easily separated from the sign panel so that it can be rolled up and stored. Specify the sign legend when ordering.

PART #	SIZE	MATERIAL
RUNR48-200	48"	Non-reflective orange
RUR48-200	48"	Super Bright™ reflective orange
RUR48DG-200	48"	Diamond Grade™ reflective orange

Non-Reflective signs are for day use only.
Reflective signs are for both day and night use.



Shown with optional folding 18" flag system

MESH ROLL-UP SIGNS

Made of a non-reflective polyester, these mesh signs are a lower cost alternative to reflective vinyl signs. They fit the same stands and roll-up in the same fashion as the standard vinyl signs. Available with or without "Ribs" (Cross Bracing).

PART #	SIZE	MATERIAL
RUM48-200	48"	With cross bracing
RUM48-SO	48"	Without cross bracing
RR200-48	48"	Cross bracing only

Non-Reflective signs are for day use only.



TRAFFIC & WORK ZONE SAFETY

The TF12W and DL1003W have aluminum legs that telescope from 30" to 51". They also come with a two position height adjustment and standard with the Screwlock™ type sign holder. This holder will accept all standard 1-1/4" wide fiberglass cross braces. Other types of sign holders are available. All sign stands are MUTCD and NCHRP-350 compliant. Stands do not include flags. See page 143 to order flags.



DYNALITE™ SIGN STAND

At only 7 lbs. this lightweight stand is perfect for low wind applications.

PART #
DL1003W



TWINFLEX™ SIGN STAND

This stand features two vertical steel coil springs for maximum strength in windy conditions.

PART #
TF12W



TWINFLEX™ TALL SIGN STAND

This unit comes with a two piece telescoping mast that can hold signs 7' off the ground. It also incorporates 2 heavy duty vertical springs for greater wind resistance.

PART #
TF84RUB



STACKER™ SIGN STAND

This low profile stand is ideal for limited storage areas. At 42 lbs., it has two molded carrying handles. The standard model comes equipped with the "Screwlock™" sign holder. Stored size 3" Tall x 20" Wide x 28" Long.

PART #
DSB-100-W

TRAFFIC & WORK ZONE SAFETY

All Fold & Roll signs and stands are MUTCD and NCHRP-350 compliant.



DYNAFLEX FOLD & ROLL SYSTEM

The Fold & Roll System is designed for compact storage and is sold as a single unit consisting of a sign and a stand. The vinyl sign and stand can be stored while being attached eliminating separate storing spaces. Storage dimensions are 7-1/4" x 7-1/4" x 45". Specify sign legend when ordering.

PART #	SIZE	SIGN MATERIAL
DF3003X48	48"	Super Bright™ reflective orange
DF3003X48NR	48"	Non-reflective orange
DF3003X48M	48"	Mesh, non-reflective orange

Fold & Roll Systems include flag holder and flags.



DYNAFLEX SIGN STAND ONLY

Designed with two horizontal coil springs to handle the harshest of conditions. The 30" legs telescope to 51" and the stand can adjust to two different heights.

PART #
DF3003S



DYNAFLEX SIGNS ONLY

Made of heavy-duty reflective vinyl or non-reflective vinyl or mesh. Specify sign legend when ordering.

PART #	SIZE	SIGN MATERIAL
3003XP-48	48"	Super Bright™ reflective orange
3003XP-48NR	48"	Non-reflective orange
3003XP-48M	48"	Mesh, non-reflective orange

TRAFFIC & WORK ZONE SAFETY

See page 148 for barricade tape.



TRAFFIC CONE

With 6" top & 4" bottom reflective collars. Stands 28" and weighs 10 lbs. with cleated bottoms to grip the road. Stenciling is available.

PART #
28TC-RC



COLLAPSIBLE CONE

Made with heavy duty nylon, these 28" cones collapse into a 2" PVC base with rubber feet. A LED light inside the cone provides night time visibility and can be set to steady or flash.

PART #	DESCRIPTION
28CC-RC	Set of 2



SAFETY CONE HANGER

The unique safety cone hanger was designed to rest on the cone. The hanger is 20" tall and brings the barricade tape above the cone for more visibility.

PART #
1MA-HANGER



TRAFFIC CONE ADAPTER

Designed to fit traffic cones ranging in height from 12" to 36" and has two different adapter head sizes to securely fit a wide range of cone top diameters.

PART #
1635-TC



RETRACTA-CONE

Cordon off working areas to create safer working environments. Custom belts: choose from solid colors, prints or messages. Choose from 4 belt end options.

PART #	UNIT COLOR	LENGTH	STOCK BELT OPTIONS
RC10	Orange	10'	Black/Yellow diagonal
RC15	Orange / Yellow	15'	Choice of 25 options



RETRACTABLE CONE BARS

These barricade bars adjust from 6' to 10' and fit over almost any traffic cone. Made with engineer grade reflective sheeting. Weighs only 1.35 lbs.

PART #	COLORS
CBYB-10	Yellow / Black
CBOB-10	Orange / White



Meets all MUTCD specifications

VINYL ROLL-UP STOP & SLOW PADDLES

Available in 18" and 24" octagons and in a variety of reflective and non-reflective materials, these kits come complete with double sided roll-up sign face, handle, and storage bag. Stored size: 3" x 8" x 38".

PART #	SIZE	MATERIAL
NR183A	18"	Non-reflective
SB183A	18"	Reflective superbright
NR243A	24"	Non-reflective
SB243A	24"	Reflective superbright



Meets all MUTCD specifications.

RIGID PLASTIC STOP & SLOW PADDLES

Available in 18" or 24" octagons on a 12" plastic staff.

PART #	SIZE	MATERIAL
P18NR	18"	Non-reflective
P18EG	18"	Reflective engineer grade
P24NR	24"	Non-reflective
P24EG	24"	Reflective engineer grade



GROUND FLAGS

Hi-visibility GROUNDS flags with two reflective strips on front and back for easy visibility when working at night. Hook and loop straps for a secure attachment. Wire attachment for hot line clamp on top and PVC stiffener on bottom.

Measures 17-1/2" H x 16-1/2" W.

PART #	COLOR
DNGF1618	Hi-visibility orange
DNGF1618-LG	Hi-visibility green



TAG HOLDER

Red vinyl/clear view vinyl message side.

PART #	SIZE
TE2180	5-1/2" x 11"



3" X 1,000' TAPE ONLY

These tapes can also be customized with an imprint of your company's name, logo and telephone number.

PART #	COLOR / WORDING
17779-C	Yellow "Caution"
17779-D	Red "Danger"



REUSABLE BARRICADE TAPE

PART #	DESCRIPTION
9999-YBY	Yellow / Black / Yellow - 2" x 300' roll
9999-RYR	Red / Yellow / Red - 2" x 300' roll

MEASURING EQUIPMENT



TELEHEIGHT

Helps to quickly determine the height of poles, trees or conductor clearance.

PART #
CW



LASER RANGE FINDER

Calculates horizontal, vertical and slope distance. Typical range is 3,280' with a max of 6,560' to a reflective target. Typical distance accuracy ± 1 ft.

PART #
7005026



LASER DISTANCE METER

Equipped with a digital Pointfinder, high-resolution 2.4" color display, 360° tilt sensor and bluetooth® technology.

PART #
D8



RR318N



MP301



32-300S



32-400

MEASURING WHEELS

Each unit collapses to about half their size, includes stands and 5-digit counters. The RR318N and RR418 measures up to 9,999'11" and the MP301 counts up to 99,999'.

PART #	WHEEL TYPE	CIRCUMFERENCE
RR318N	ABS plastic wheel	3'
RR418	ABS plastic wheel	4'
MP301	Spoked wheel	3'

MEASURING WHEELS

The 5-digit counters records up to 100,000'. Model 300S has an attached stand but the 300 does not. The 400 comes standard with a stand. Measures in feet only.

PART #	WHEEL TYPE	CIRCUMFERENCE
32-300	Plastic wheel	3'
32-300S	Plastic wheel with stand	3'
32-400	Spoked wheel	4'



REMOTE CONTROL LIGHT

This powerful 400,000 candle power light comes with a programmable wireless remote, suction cup with magnetic mounting shoe and 15' cord with 12 VDC lighter plug. 370° rotation & 135° tilt.

PART #	DESCRIPTION
7901	White
7951	Black



LED REMOTE CONTROL LIGHT

includes programmable wireless remote, suction cup & magnetic mounting shoe, 15' cord with 12 VDC lighter plug. Uses 3Ah with 12 V power source. 370° rotation & 135° tilt.

PART #	DESCRIPTION
79014	White
79514	Black



DUAL REMOTE CONTROL LIGHT

Similar in size and power to the 7901 Remote Light, this unit offers a dash mounted remote as well as a wireless remote control. Complete with hardware for permanent mounting.

PART #	DESCRIPTION
2007	White
2057	Black



LED RETROFIT INSERT

Retrofit existing Golight spotlights and realize the intensity, reduced power consumption, and increased bulb life.

PART #
15444



LITEBOX® FLASHLIGHT

A powerful light with 90° swivel head that comes with a high-intensity halogen bi-pin 8 watt spot bulb. Other bulbs are available. Complete kit includes shoulder strap, A/C and D/C chargers and mounting rack.

PART #
45116



LED LITEBOX® FLASHLIGHT

3 powerful LED's and deep dish parabolic reflectors produce a large spot pattern. The LED's are impervious to shock and have a 50,000 hour life. It has both Hi and Low power settings. The kit includes shoulder strap, A/C and D/C chargers and mounting rack.

PART #
45851



E-FLOOD® LITEBOX® HL™

Six C4® LEDs and wide pattern reflectors produce a uniform flood pattern with two selectable beam widths and three light output intensities. Toggle switch allows operation from internal battery or continuous operation from external 12 VDC power source.

PART #
45661



HID LITEBOX® FLASHLIGHT

The HID Litebox has the intensity and peripheral illumination to light an entire scene. Four 5 mm white LEDs placed in the front of the housing provides low-light maneuvering. The HID lamp can run up to 134 hours on a single charge and the LEDs up to 100.

PART #
45601

WORK ZONE LIGHTING



WAYPOINT PISTOL GRIP SPOTLIGHT

Spotlight features 3 modes: High, Low & Strobe.
4 "C" alkaline batteries (sold separately).
Includes 12 VDC power cord. C4® LED technology.
IPX4, water resistant (1 meter impact resistance tested).

PART #	COLOR
44900	Yellow
44902	Black



WAYPOINT RECHARGEABLE SPOTLIGHT

Spotlight features 3 modes: High, Low, Emergency Signal.
Rechargeable Lithium-ion battery, recharges in 4 hours.
Includes 5 ft., 120 VAC charge cord. C4® LED technology.
IPX8: submersible to 2 meters (floats if dropped in water).

PART #	COLOR
44910	Yellow
44911	Black



24-16A



45937



45845



22060

LITEBOX ACCESSORIES

PART #	ITEM
24-16A	LiteBox holder for all Liteboxes
22051	12 VDC charger cord for all Liteboxes
22060	120 VAC charger cord for Litebox
22665	120 VAC charger cord HID Litebox
45937	Replacement battery for Litebox
45630	Battery for HID Litebox
45842	E-Flood LED upgrade kit
45845	E-Spot LED upgrade kit

WORK ZONE LIGHTING



90627



90657

KNUCKLEHEAD® SERIES

Class I, Division 2. C4® LED technology for extreme brightness. 360° rotation head with 210° of articulation. IPX4 rated water resistant operation. 2 meter impact resistance tested. Removable magnet and integrated hook.

PART #	ITEM	COLOR
90627	Rechargeable model	Yellow
90657	Rechargeable model with clip	Orange
90644	Alkaline model with clip	Orange
90642	Alkaline model	Yellow



RADIUS™ LED COMPACT SITE LIGHT

20% Brighter than 500w halogen flood light. Three light output modes for optimal brightness and runtime.

PART #	LUMENS
2145-20	1,000 - 4,000



HAZ-LO® SAFETY RATED FLASHLIGHT

The 3C ProPolymer alkaline battery-powered flashlight is waterproof and features C4® technology LEDs. UL Listed for Class I, Division 1.

PART #
33820



STRION® LED HL® RECHARGEABLE FLASHLIGHT

Ultra compact & powerful, this rechargeable flashlight offers 3 microprocessor controlled variable intensity modes, strobe mode and the latest in high power C4® LED technology.

PART #	DESCRIPTION
74751	Strion LED HL with 120 VAC/12 VDC – 1 holder
74753	Strion LED HL 120 VAC
74754	Strion LED HL with 12 VDC

STIRION ACCESSORIES

PART #	DESCRIPTION
22051	DC1 charge cord
22311	120 VAC charge cord
74175	Battery stick (Lithium-ion)



SEARCH LIGHT KIT

1,250 lumens with 700 yard beam distance, 198° head rotation, 4 modes: spot, flood, spot/flood, & strobe.

PART #	LUMENS
2354-21	600 - 1,250



ROCKET™ DUAL PACK TOWER LIGHT

One key enabled. Accepts 1 or 2 M18 batteries. Quick seven second setup with three different leg deployment options. Adjusts up to 65" high. Collapsible to 22". Weighs 24 lbs.

PART #	LUMENS
2120-20	1,600 - 5,400



ROCKET™ LED TOWER LIGHT

Rotating and pivoting head is extendable from 4'-7'. Three light output modes for optimal brightness and runtime. Impact resistant reinforced legs.

PART #	LUMENS
2130-20	850 - 2,000



ROCKET™ LED TOWER LIGHT/CHARGER KIT

7' Max extension. Multidirectional light. Impact resistant, reinforced legs. Built in M18™ charger, covered AC plug-in. 3 Independently pivoting light heads.

PART #	LUMENS
2135-21	900 - 3,000



ROVER™ LED DUAL POWER FLOOD LIGHT

20% brighter than 500W halogen flood light. Three light output modes for optimal brightness and runtime.

PART #	LUMENS
2360-20	600 - 1,250



UTILITY BUCKET LIGHT

2,500 lumens with 500 yard beam distance. Dual Light head design with 180° of vertical and horizontal head rotation. 3 output modes: Spot, Flood, Spot/Flood. Patented spring loaded bucket clamp for all bucket sizes.

PART #	LUMENS
2122-21HD	2,500



ROVER™ LED FLOOD LIGHT

High definition lighting technology. 30% brighter than corded 250 halogen lights. Up to 8 hours of run-time.

PART #	LUMENS
2361-20	1,500

WORK ZONE SAFETY APPAREL



SAFETY SHIRTS

Made of a wicking polyester material, these shirts are available in orange and lime colors. Rated ANSI Class 2.

PART #	SIZES	COLOR
TS19	S - 5XL	Plain lime shirt
TS29	S - 5XL	Plain orange shirt
TS100	S - 5XL	Lime shirt with reflective stripes
TS200	S - 5XL	Orange shirt with reflective stripes



SAFETY VEST

Made with a solid front and mesh back, 2" reflective stripe within a 4" lime stripe. It also features an expandable radio pocket, one inner and outer pocket and a zipper closure.

PART #	SIZES
V-1200	M - 5XL

SAFETY VEST

This standard lime-green vest has hook & pile closure, 2" reflective stripes and are ANSI rated Class II.

PART #	SIZES
V-30	M - 5XL



ARC RATED HI VIS SOLID VEST

Class 2 Hook and Loop closure
 ATPV = 5.5 cal/cm², HRC Level 1
 ASTM F1506, NFPA 70E
 Meets ANSI 107-2010, Class 2
 2" Silver heat transferred trim. 27" length.

PART #	SIZES
V-8A0112VL	M - 6XL

ARC RATED HI VIS MESH VEST

Basic Class 2 Vest. Modacrylic mesh and binding. Meets ANSI 107-2010, Class 2.
 2" Silver heat transferred trim.
 Hook & loop front closure.
 27" length.

PART #	SIZES
V-8AM0112VL	M - 6XL

ARC RATED HI VIS MESH VEST

Non-conductive zipper closure.
 Modacrylic mesh and binding. Open-sides with adjustable snaps. Meets ANSI 107-2010, Class 2.
 2" Silver heat transferred trim. 27" length.

PART #	SIZES
V-8AM0312ZL	S - 5XL

WORK ZONE SAFETY APPAREL



DUCK BILL HARD HAT

Featuring a comfortable six-point suspension and ANSI/ISEA Z89.1-2009, CSA Z94.1-2005, Type 1, Class E & G requirements.

PART #	COLOR
C30WH	White
C30YL	Yellow



FULL BRIM HARD HAT

Featuring a comfortable six-point suspension and ANSI/ISEA Z89.1-2009, CSA Z94.1-2005, Type 1, Class E & G requirements.

PART #	COLOR
C33WH	White
C33YL	Yellow



FULL BRIM HARD HAT

Features four-point suspension with ratcheting head band and slotted sides ANSI rated Type 1, Class E.

PART #	COLOR
50210-10	White
50210-41	Yellow



DUCK BILL HARD HAT

Features six-point suspension with ratcheting head band and slotted sides ANSI rated Type 1, Class E.

PART #	COLOR
50200-10	White
50200-41	Yellow



SEPTOR® LED HEADLAMP

The Septor® headlamp features seven ultra bright 100,000 hour life white LEDs that sequences through (1) LED, (3) LEDs, (7) LEDs and off.

PART #	MAXIMUM LUMENS
61052	120



TRIDENT® LED HEADLAMP

The Trident® features a single C4® power LED with three Ultra Bright 5mm white LEDs. Push-button sequence through: One (1) 5mm LED, Three (3) 5mm LEDs, C4 power LED, and off.

PART #	MAXIMUM LUMENS
61050	80



ARGO® LED HEADLAMP

The Argo® headlamp features a single C4® power LED for long distance lighting with three output modes: (1) LED, (3) LEDs, (7) LEDs and off.

PART #	MAXIMUM LUMENS
61301	150



3AA HAZ-LO® HEADLAMP

The 3AA Haz-Lo® is a compact, long running, high performance C4® LED headlight. Engineered to meet the stringent requirements of Division 1 hazardous locations.

PART #	MAXIMUM LUMENS
61200	120



ENDURO HARD HAT LIGHT

The .5 watt LED has 100,00 hour life and a run time of 6 hours on high and 24 hours on low. The lamp can be removed from the rubber/elastic head strap and clipped to the brim of a hat.

PART #	MAXIMUM LUMENS
61400	14.5



HEADLAMP

UL Listed for Class I, Division 1. The head unit is self contained, waterproof, and constructed of high grade materials. The Maxbright LED puts out 70 lumens and a spot beam that reaches as far as 65 meters.

PART #
EOS II



REDVEL WINTER LINER
Twill shell with red fleece lining. Non-durable flame retardant. Three loop straps with adjustable closure. Regular nape.

PART #
68800



SUPER 3M WINTER LINER
100% cotton twill shell treated with flame retardant with soft fleece lining and 3M Thinsulate insulation. Non-durable fire retardant. Three loop straps with adjustable closure. Long nape.

PART #
63900



3M THINSULATE WINTER LINER
100% cotton twill shell, treated with flame retardant with 3M Thinsulate insulation for ultimate protection from the cold. Soft fleece lining. Three loop straps and adjustable neck closure.

PART #
71300



NEMESIS SUNGLASSES WITH CORD
Scratch resistant hard coated lenses. Lenses are made of a polycarbonate material that provides 99.9% UVA/UVB/UVC protection. Meets ANSI Z87.1+ standards for impact.

PART #	LENS COLOR
25676	Clear
25659	Amber
25688	Smoke



SMITH & WESSON ELITE SAFETY GLASSES
Lightweight "retro-style" design. High performance polycarbonate lens provides 99.9% UV protection. Exceeds the "High Impact" level of the ANSI Z87.1-2015 safety standards.

PART #	LENS COLOR
50056	Clear
50057	Amber
50058	Smoke



FIRST AID KIT

ANSI First Aid Kit for 10 persons with crucial first aid items compliant with ANSI 2009 specifications.

PART #
GFAP-21-05



5 GALLON WATER COOLER

PART #
WC-5



INSECT REPELLENT

Repels gnats, mosquitoes, biting flies, chiggers, ticks, flying insects and fleas on skin surfaces. Contains extra strength 25% DEET formula. Provides long lasting protection against lyme disease, rocky mountain spotted fever and west nile virus.

PART #
4501



WASP & ANT KILLER

Three powerful ingredients provide quick knockdown. The forceful shotgun spray pattern can be used from a safe distance of 15 feet. With a dielectric strength of 47,300 volts, it's safe to use in and around pad-mounted transformers, pull boxes and meter boxes.

PART #
4335



HAND & TOOL CLEANING TOWELS

These towels are specially formulated to dissolve and absorb dirty contaminants from hands, tools, and equipment. Removes icky pzie, c-cement, tar, asphalt, heavy greases and more.

PART #
79315



VINYL FLAG

Fluorescent red/orange flag on a staff.

PART #	FLAG SIZE	STAFF
KVF1827	18"	27"
KVF2436	24"	36"



TT-5



TT-9

FLAG HOLDER

Flags not included.

PART #	DESCRIPTION
TT-5	Single flag holder
TT-9	3 Flag adapter for TT-5



LED POLE LIGHT WITH DUAL FLAG HOLDER

LED is rated for 100,000 hours of heavy duty operation.

Includes four flash patterns: Comet, Single, Steady Burn and Flare Flicker. Powered by three alkaline "C" batteries that provide 100+ hours of continuous operation. Easy to attach and deploy. Includes batteries and two red flags.

PART #	LENS COLOR
TE7015-A	Amber
TE7015-R	Red

WHEEL CHOCKS

100% recycled tire rubber wheel chocks are resistant to weather, salt, moisture, UV, oil, and temperature. These durable chocks are skid resistant, will not damage tires or pavement and meet EPA and OSHA requirements.

PART #	SIZE	WEIGHT
MRQ-C	10"L x 8"W x 6"H	11.5 lbs.



VEHICLE & TRANSPORT EQUIPMENT



Series 5,000



Series 10,000



Series 15,000

RATCHETING LOAD STRAPS

Polyester strap assemblies include flat hooks.

Many other hooks and styles are available.

PART #	SERIES	STRAP SIZE	WLL
60501	5,000	2" x 27'	1,600 lbs.
61001	10,000	2" x 27'	3,300 lbs.
20482	15,000	3" x 27'	5,000 lbs.



Lever type



Ratchet type

LOAD BINDERS

Used to tighten chain for securing cargo.

PART #	TYPE	GRADES	CHAIN SIZE	WLL
48769	Lever	30-43-70	3/8"-3/8"-3/8"	7,100 lbs.
48306	Lever	30-43-70	1/2"-1/2"-3/8"	9,200 lbs.
48366	Ratchet	30-43-70	1/2"-3/8"-3/8"	9,200 lbs.
48367	Ratchet	30-43-70	5/8"-1/2"-1/2"	13,000 lbs.



GRADE 70 BINDER CHAINS

Includes grab hooks. Many other sizes, styles and lengths are available.

PART #	TYPE	WLL
0513665	3/8" x 20'	6,600 lbs.
0513765	1/2" x 20'	11,300 lbs.



DRAWBAR

Designed to attach to the end of the pole.

The chain & tightener force the 4 studs deeply into the pole.

Use with 3-5 Ton trailers.

PART #
165-A-100



172-A-51

PORTABLE POLE BINDER

Used for binding loads of poles. Both units come with 18' of wire rope. Base plate used to mount binder to trailer or body.

PART #	DESCRIPTION
172-A-51	Pole binder
107301	Pole binder with baseplate

GROUND PROTECTION MATS

TALLMAN RENTS GROUND MATS.

These mats are designed to prevent heavy equipment from damaging lawns or landscaped areas and from getting stuck in mud or soft, wet terrain. They are less expensive than fiberglass and more costs effective than plywood.



Holes in the corners allow mats to be connected with the Turn-A-Links listed below.



Add H to the part number for built in handles. (i.e. AM48-H)

ALTURNAMATS®

These rugged mats are made of 1/2" polyethylene and are virtually indestructible.

With a bold cleat design, these mats can support 60 Ton loads and have been tested in extreme cold and heat.

Available in black or white. They can be locked together to form a continuous roadway or large work area. Order links separately.

PART #	SIZE	WEIGHT
AM24	2' x 4'	21.5 lbs.
AM26	2' x 6'	32.35 lbs.
AM28	2' x 8'	43 lbs.
AM48	4' x 8'	86 lbs.

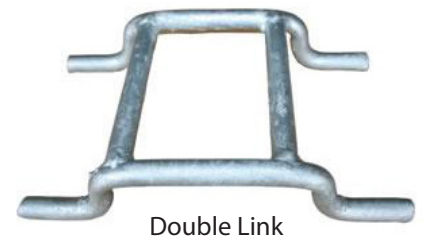

TURN-A-LINK

Turn-A-Links connect easily and create an instant portable roadway or working platform for as long as you need it.

Made of rugged 1/2" round hot roll steel with a galvanized coating.

PART #	LINK TYPE
RTL-S-G	Single - connects 2 mats end to end
RTL-D-G	Double Link - connects 4 mats at the corners

OUTRIGGER PADS



CONSTRUCTION MATS

These rugged mats are made from mixed hardwood lumber. They are comprised of 3 layers of 1-1/2" x 8" boards and are bolted together with 1/2" countersunk carriage bolts leaving both sides smooth.

PART #	SIZE	APPROXIMATE WEIGHT
TECM8X14	8' x 14'	1,600 lbs.
TECM8X16	8' x 16'	1,700 lbs.

MEDIUM DUTY POLYETHYLENE PADS

Made of high density polyethylene these pads feature a safety textured finish and bright orange rope handles. The solid, lightweight, single material will bend but not break.



HEAVY DUTY PADS

Handles loads over 60,000 lbs. and manufactured with an anti-slip surface. Handles are made of stainless steel wire rope and bolted to the pad. Custom sizes available.



Company name engraved in every outrigger pad

MEDIUM DUTY PADS

PART #	SIZE	WEIGHT
PAD-24241	24" x 24" x 1"	20 lbs.
PAD-30301	30" x 30" x 1"	31 lbs.
PAD-36361	36" x 36" x 1"	45 lbs.
PAD-48481	48" x 48" x 1"	80 lbs.

MEDIUM DUTY CAPACITIES

PART #	VERTICAL	45° ANGLE
PAD-24241	60,000 lbs.	35,000 lbs.
PAD-30301	81,000 lbs.	41,000 lbs.
PAD-36361	93,000 lbs.	43,000 lbs.
PAD-48481	135,000 lbs.	52,000 lbs.

1" OUTRIGGER PADS

PART #	SIZE	WEIGHT
OL-24241	24" x 24" x 1"	20 lbs.
OL-30301	30" x 30" x 1"	33 lbs.
OL-36361	36" x 36" x 1"	48 lbs.
OL-48481	48" x 48" x 1"	63 lbs.

2" OUTRIGGER PADS (ALSO AVAILABLE IN ROUND PADS)

PART #	SIZE	WEIGHT
OL-24242	24" x 24" x 2"	40 lbs.
OL-30302	30" x 30" x 2"	63 lbs.
OL-36362	36" x 36" x 2"	90 lbs.
OL-48482	48" x 48" x 2"	162 lbs.

REEL LIFTS, PAYOUT & TAKE UP REELS

See 386 for 176-A-78 repair parts.



PAYOUT REEL

Specially suited for gang mounting on a truck bed or trailer when paying out several wires simultaneously. It adjusts to accept 12", 18" or 24" diameter coils. Maximum coil diameter is 33". Made of reinforced hardwood.

PART #	WEIGHT
902	40 lbs.



COLLAPSIBLE CABLE REEL

Commonly referred to as a "Butterfly Reel", this reel is used for winding wire into neat coils. It then collapses so that the coiled wire can be easily removed. It's designed to attach to a 2-7/16" winch shaft and weighs 70 lbs.

PART #	WEIGHT
176-A-78	40 lbs.



PAYOUT REEL

This all purpose portable payout reel can be set horizontally or vertically. A tension brake prevents the reel from coasting, eliminating backlash or unraveling of the wire. Adjustable from 8" to 12" and the inside diameter adjusts from 15" to 30".

PART #	WEIGHT
301-1	150 lbs.

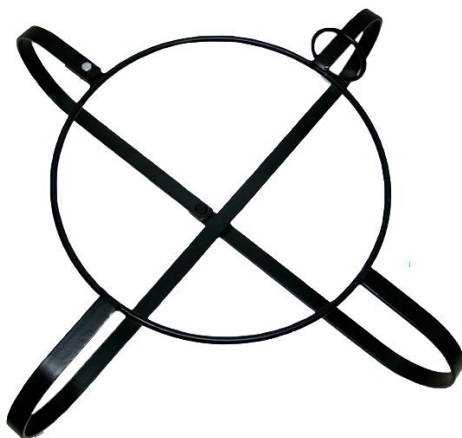

STRAND & WIRE DISPENSER

Easy to use wire dispenser. Lift the pivoting arm, drop in the coil, lower the arm, cut the bands and feed the wire. Stores full and partially used coils.

PART #	DIMENSIONS
6150	6" Deep x 30" Wide
61501	8" Deep x 36" Wide



TRIPLEX DISPENSER

Made of zinc coated steel, it has 8 adjustable arms to quickly load, unwind and rewind coils of various sizes. Accepts coils up to 32" outside diameter with a maximum width of 10-1/4".

PART #	ITEM
5478	Dispenser
5074	Mounting base plate



GUY WIRE DISPENSER

Coils are simply rolled into then stand and clamped into place with 4 adjustable arms for easy unwinding and rewinding. Holds coils with diameters up to 31" and widths of 4-3/4".

PART #	ITEM
5276	Dispenser
5074	Mounting base plate

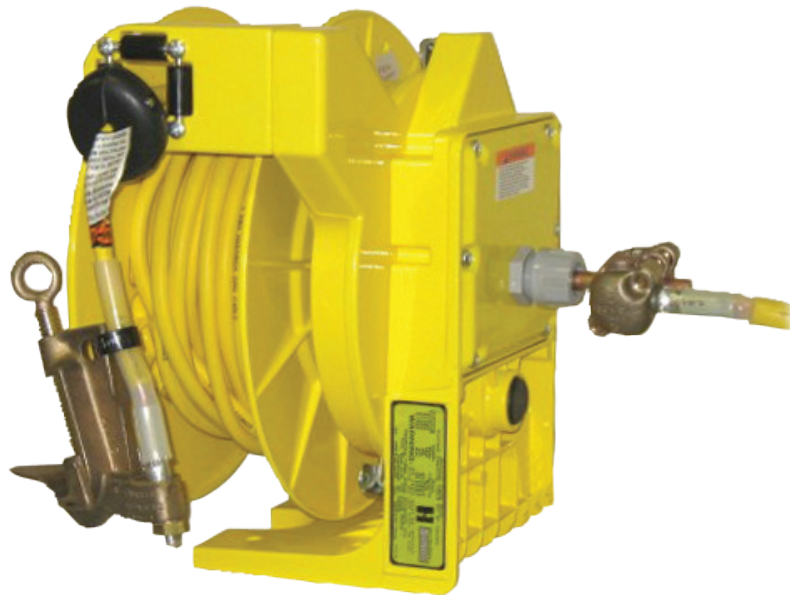

TRUCK GROUNDING REELS

Provides an efficient and positive means to ground trucks near energized electrical lines. Each reel with factory installed cable includes a 6' length of 2/0 ground cable to connect to the truck and a bronze body clamp to attach to the ground rod.

PART #	DESCRIPTION
21364	Grounding reel with 40' of 1/0 cable and clamp
21365	Grounding reel with 40' of 2/0 cable and clamp
21374	Grounding reel with 50' of 1/0 cable and clamp
21375	Grounding reel with 50' of 2/0 cable and clamp

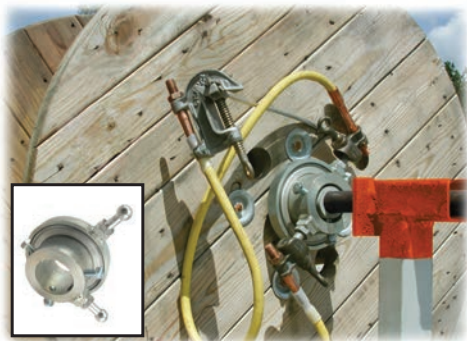

ROTATING GROUND ADAPTER

This unique tool provides protection while the conductor is pulled from reels. It adds conductor grounding but does not replace other grounding practices. The adapter slides on the reel mandrel. The outer collar connects to the tail of the conductor on the reel and the inner collar is connected to a ground rod.

PART #
GR43BS2



CABLE REEL GROUNDING SET

Consisting of a 3' length and a 15' length of 2/0 yellow jacketed cable, both with ball stud clamps on one end and C-type clamps on the other.

PART #
TEG2B2M



SCREW GROUND ROD

A temporary 6' copper clad ground rod with T-handle.

PART #
DNTGR



4001AF

4002AF

4043AF

WOOD SHELL BLOCKS FOR MANILA ROPE

Hard wood shell blocks with galvanized metal parts.

Supplied with bronze bushed bearings.

PART #	# OF SHEAVE	SIZE	ROPE SIZE	WLL
4001AF	Single	4"	1/2"	1,000 lbs.
6001AF	Single	6"	3/4"	1,800 lbs.
4002AF	Double	4"	1/2"	1,400 lbs.
6002AF	Double	6"	3/4"	2,500 lbs.
4003AF	Triple	4"	1/2"	1,800 lbs.
6003AF	Triple	6"	3/4"	3,200 lbs.



Drop-Link Style
3071V

Locking Style
3072V

WOOD SNATCH BLOCKS FOR FIBER ROPE

Drop link blocks are primarily used as lead blocks and are not recommended for hoisting.

Both styles have self-lubricating bushings.

PART #	SHEAVE SIZE	ROPE SIZE	WEIGHT	WLL
3071V-6	6"	7/8"	2 lbs.	2,400 lbs.
3071V-8	8"	1"	12 lbs.	4,800 lbs.
3072V-6	6"	7/8"	9 lbs.	3,000 lbs.



3041AF

4042AF

4003AF

STEEL SHELL BLOCKS FOR FIBER ROPE

Heavy duty steel blocks with a galvanized finish and bronze bushed bearings.

PART #	# OF SHEAVES	SHEAVE SIZE	ROPE SIZE	WLL
3041AF	Single	3"	3/8"	700 lbs.
4041AF	Single	4"	1/2"	1,100 lbs.
4042AF	Double	4"	1/2"	1,600 lbs.
6042AF	Double	6"	3/4"	3,300 lbs.
4043AF	Triple	4"	1/2"	2,200 lbs.



BLOCK & TACKLE

Block and tackle comes with 50 feet of 1/2" 16 strand blue streak rope. Locking cam rated to 500 lbs.

Safe working load 2,250 lbs. 5:1 lifting ratio.

PART #	ROPE SIZE	WEIGHT	WLL
C400-0295	1/2"	20.5 lbs.	3,500 lbs.



INSULATED TACKLE BLOCKS

Designed for all types of hoisting related jobs. Bodies are made from high impact, dielectric thermoplastic material. All hooks have full swivel capabilities. Sheaves are made with fiberglass reinforced nylon material. Shafts are stainless steel. Swivel hooks are plated and include hot eye for application with hot stick. Working Load Limit 2,000 lbs.

PART #	DESCRIPTION	UPPER	LOWER	WEIGHT
11361	Blocks only - no rope	2 Sheave	2 Sheave	6.5 lbs.
11362	Blocks with 120' of 1/2" poly dacron rope	2 Sheave	2 Sheave	16.0 lbs.
11367	Blocks only - no rope	3 Sheave	2 Sheave	6.8 lbs.
11368	Blocks with 150' of 1/2" poly dacron rope	3 Sheave	2 Sheave	20.0 lbs.
11369	Blocks with 250' of 1/2" poly dacron rope	3 Sheave	2 Sheave	25.0 lbs.
11052	Single block only	2 Sheave		3.3 lbs.
11051	Single block only	3 Sheave		3.5 lbs.



INSULATED ROPE BLOCK

Double and triple blocks with 150' three-strand Polypropylene rope. The shells and sheaves are made of high dielectric, fiber filled natural nylon. The shaft is of silicon bronze and the sheave bearings are oil impregnated bronze.

PART #	ROPE SIZE	WEIGHT	WORKING LOAD LIMIT
C400-0295	1/2"	20.5 lbs.	3,500 lbs.

HALF-SIDE BLOCKS

The cast-annealed steel sides and compact design make these blocks rugged and easy to handle and feature precision-machined bronze bearings. The A-4 is available with the regular yoke only. All other models are available with either the regular yoke or swivel shackle.

PART #	SHEAVE SIZE	LINE SIZE	WEIGHT	WLL
A-4	4"	3/8"	9 lbs.	10,000 lbs.
A-6	6"	3/8" - 1/2"	17 lbs.	14,000 lbs.
A-8	8"	1/2" - 5/8"	29 lbs.	16,000 lbs.
A-10	10"	5/8" - 3/4"	34 lbs.	16,000 lbs.



Regular Yoke

CAST SIDED BLOCKS

Made of the same steel and with the same bearings as the half-side blocks, the sheaves of these cast sided blocks are fully protected. All of these blocks are available with either a swivel shackle, swivel hook or swivel hook with safety latch.

PART #	SHEAVE SIZE	LINE SIZE	WEIGHT	WLL
S-4	4"	3/8"	11 lbs.	6,000 lbs.
S-6	6"	3/8" - 1/2"	26 lbs.	13,000 lbs.
S-8	8"	1/2" - 5/8"	32 lbs.	13,000 lbs.
S-10	10"	5/8" - 3/4"	44 lbs.	14,000 lbs.

For Swivel Shackle, use suffix "SS"
 For Swivel Hook only, use suffix "SH"
 For Swivel Hook with Safety Latch, use suffix "SHL"



Swivel Hook with Safety Latch

WIDE SHEAVE - WIDE THROAT BLOCKS

With sheaves made from manganese metal, these durable blocks provide a long service life. Timken bearings come standard on wide throat blocks except the R-4 which has roller bearings.

All available with regular yoke only.

PART #	SHEAVE SIZE	LINE SIZE	WEIGHT	WLL
R-4	4"	3/8"	12 lbs.	10,000 lbs.
R-6	6"	3/8" - 1/2"	30 lbs.	16,000 lbs.
R-8	8"	1/2" - 5/8"	43 lbs.	16,000 lbs.
R-10	10"	1/2" - 5/8"	50 lbs.	18,000 lbs.



R-4



R-10



ALLOY SNATCH BLOCKS

PART #		SHEAVE DIAMETER	WIRE SIZE	BLOCK WEIGHT		WORKING LOAD LIMIT
HOOK	SHACKLE			HOOK	SHACKLE	
1000136	1000137	4"	1/4" - 1/2"	10 lbs.	9 lbs.	4 Tons
1000142	1000143	6"	5/8" - 3/4"	25 lbs.	21 lbs.	8 Tons
1000145	1000146	8"	5/8" - 3/4"	32 lbs.	29 lbs.	8 Tons
1000700	1000703	8"	3/4" - 7/8"	52 lbs.	48 lbs.	15 Tons
1000711	1000712	8"	1-1/8"	95 lbs.	84 lbs.	20 Tons
1000151	1000152	10"	5/8" - 3/4"	41 lbs.	38 lbs.	8 Tons
1000341	1000342	10"	3/4" - 7/8"	55 lbs.	56 lbs.	15 Tons
1000808	1000809	10"	1" - 1-1/8"	112 lbs.	101 lbs.	20 Tons



SNATCH BLOCK

5/8" rope capacity, 5-1/2" sheave and roller bearings.

PART #	WLL	WEIGHT
LH494-2	4,000 lbs.	7.3 lbs.



SNATCH BLOCK

1" rope capacity, 6" sheave and bronze oilite bearings.

PART #	WLL	WEIGHT
606B2H	5,000 lbs.	13.8 lbs.

HANDLINE BLOCKS



NHB-3



NHB-3-2



AHB-3

HANDLINE BLOCKS

Smooth running 3" sheaves accommodate rope up to 5/8" diameter. All models have a 5:1 safety factor.

PART #	TYPE	WLL
DNAHB-3	Aluminum body, open head	1,000 lbs.
DNNHB-3	Nylon body, open head	1,000 lbs.
DNNHB-3-2	Nylon body, closed head	1,000 lbs.



TOWER BLOCK

The AHB-4 is load tested prior to shipment. 4" sheaves accommodate 7/8" rope capacity. 4" sheave and shielded bearings.

PART #	WLL	WEIGHT
DNAHB-4	2,500 lbs.	6.3 lbs.

Replacement detent pin with ring & laynard
PART # TEDP5-200-T

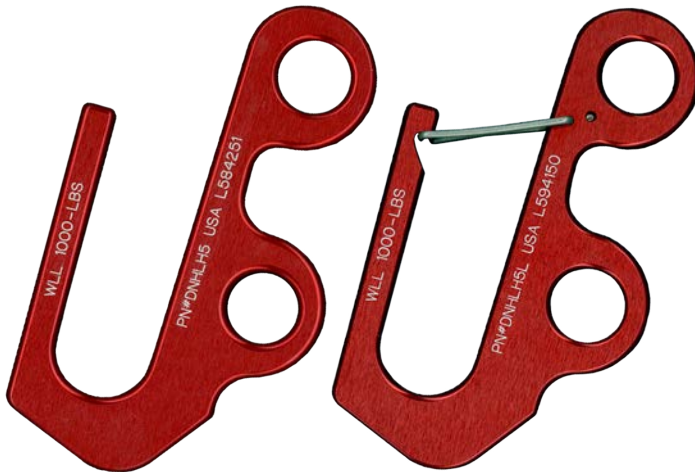

RATED HANDLINE HOOK

Made from high-strength aluminum alloy, these handline hooks are the only rated handline hooks on the market. 5:1 Safety Factor. Available with spring steel latch.

PART #	WLL	DIMENSIONS
DNHLH5	1,000 lbs.	7" x 4" x 1/2"
DNHLH	1,000 lbs.	7" x 4" x 1/2" with latch



470



DR-2



HLH2



T258

HANDLINE ACCESSORIES

PART #	DESCRIPTION
470	Swivel snap hook
DR-2	2" Handline ring
HLH2	Handline hook
T258	Handline hook

CUSTOM HANDLINE ASSEMBLIES

Custom handlines can be made to suit your needs with either aluminum or nylon blocks and 1/2" or 5/8" diameter SAMSON 3-strand rope. Standard sets come with the # 258T double eye hook. Each set includes an adjustable 9' "Becket" to hold the handline in place.



ALUMINUM BLOCKS SETS



AHB-3

PART #	BLOCK	ROPE LENGTH	ROPE DIAMETER
HLH508A-40	AHB-3	80'	1/2"
HLH508A-50	AHB-3	100'	1/2"
HLH508A-75	AHB-3	150'	1/2"
HLH508A-100	AHB-3	200'	1/2"
HLH510A-40	AHB-3	80'	5/8"
HLH510A-50	AHB-3	100'	5/8"
HLH510A-75	AHB-3	150'	5/8"
HLH510A-100	AHB-3	200'	5/8"

NYLON BLOCKS SETS



NHB-3

PART #	BLOCK	ROPE LENGTH	ROPE DIAMETER
HLH508N-40	NHB-3	80'	1/2"
HLH508N-50	NHB-3	100'	1/2"
HLH508N-75	NHB-3	150'	1/2"
HLH508N-100	NHB-3	200'	1/2"
HLH510N-40	NHB-3	80'	5/8"
HLH510N-50	NHB-3	100'	5/8"
HLH510N-75	NHB-3	150'	5/8"
HLH510N-100	NHB-3	200'	5/8"



Standard reel lengths of 600' & 1,200'

HANDLINE ROPE

A soft 3 strand rope with an excellent grip. It's high strength and low make this an ideal handline rope. Made of high strength polyester fiber wrapped over high tenacity Ultra-Blue fiber.

PART #	DIAMETER	MINIMUM TENSILE
SNHP08	1/2"	6,200 lbs.
SNHP10	5/8"	9,000 lbs.

OX BLOCK

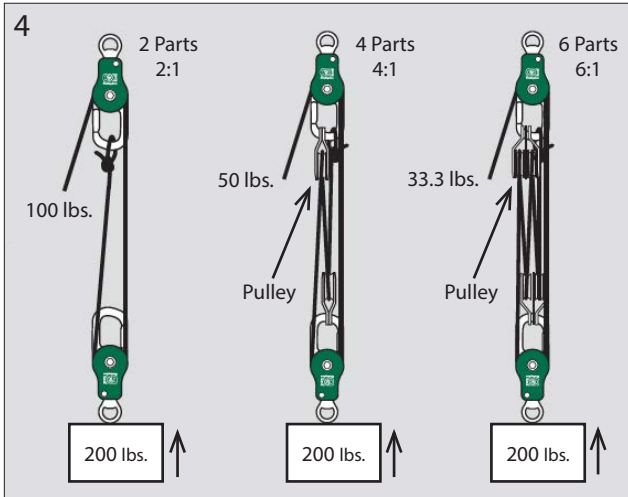
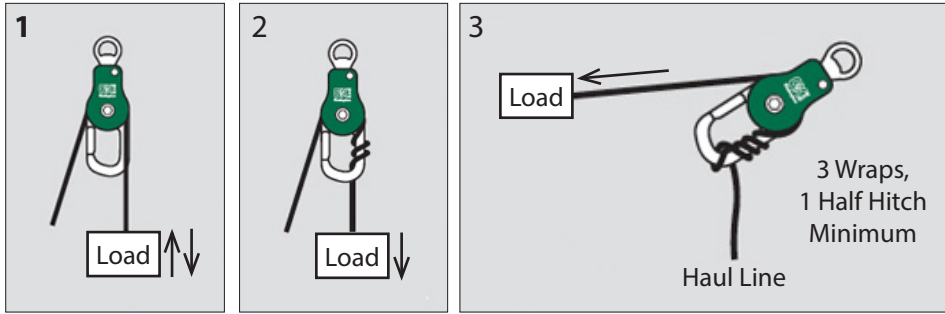

Approximate line length required:
(Lift length x number of pulleys) + 1 lift length.

CONFIGURATIONS

- 1: Common
- 2: Lowering load w/ friction
- 3: Snubbing load
- 4: Raising load



OX BLOCK™

The Ox Block™ rope snatch block with an integrated friction bar is used for hurtman rescue, lowering loads, snubbing loads, and raising loads. Allows the rigging professional to handle loads with greater control and when lowering loads, tension is transferred from worker to the Ox Block™.

PART #
50061



39078TAG1-4



5007R1



5007R2



5555S3

OX BLOCK™ ACCESSORIES

PART #	DESCRIPTION
39078TAG1-4	Ox Tail™ - 4' x 5/8" adjustable sling - WLL: Straight 3,200 lbs. / Choker 2,560 lbs. / Basket 6,400 lbs.
39078TAG1-4	Ox Tail™ - 7' x 5/8" adjustable sling - WLL: Straight 3,200 lbs. / Choker 2,560 lbs. / Basket 6,400 lbs.
5007R1	Single sheave Buckrigger™ - 1/2" rope capacity and a WLL of 1800 lbf.
5007R2	Double sheave Buckrigger™ - 1/2" rope capacity and a WLL of 1800 lbf.
5555S3	Triple action aluminum carabiner - 3,600 lb. gate, 4-7/8" length 3/4" opening, MBS 6,744 lbs.

SLACK BLOCKS



1802-30SSR

COMPLETE SLACK BLOCK SETS

All slack block sets are supplied with 25' of 3/8" 3-strand poly rope. Choice of # 258 or # 259 hooks, plain or guarded snap blocks and spliced rope.

PART #	COMPONENTS
1802-30	258 Hook, 267 & 268 blocks, unspliced rope
1802-30SR	258 Hook, 267 & 268 blocks, spliced rope
1802-30S	259 Hook, 267 & 268 blocks, unspliced rope
1802-30SSR	259 Hook, 267 & 268 blocks, spliced rope
H1802-30	258 Hook, H267 & H268 blocks, unspliced rope
H1802-30SR	258 Hook, H267 & H268 blocks, spliced rope
H1802-30S	259 Hook, H267 & H268 blocks, unspliced rope
H1802-30SSR	259 Hook, H267 & H268 blocks, spliced rope



258



259



267



H267



268



H268

ANCHOR HOOKS & SLACK BLOCKS

PART #	DESCRIPTION
258	Anchor hook
259	Swivel anchor hook
267	Plain block
H267	Plain block with guarded snap
268	Plain block with eye
H268	Plain block with eye & guarded snap



HOWE WIRE TOOL

A forged swivel hook is attached to a 1" wide nylon strap. The hook is long enough to reach under the insulator while the other end holds the load at any distance. 500 lb. capacity.

PART #
1702-20N

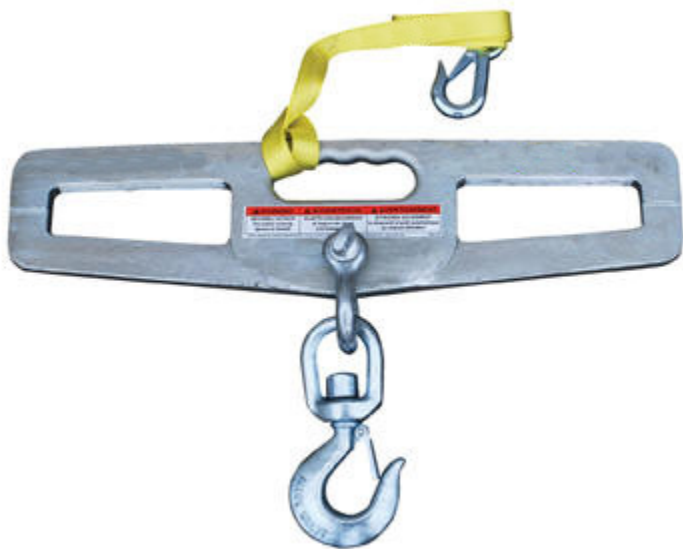

HOOK PLATE

Enables any fork truck to maximize safety while lifting a load using chains, cables or ropes. The safety restraint is used to secure the Hook Plate to the fork truck, preventing it from sliding off the end of the forks. 24" wide by 6" high.

PART #	HOOK	CAPACITY	WEIGHT
LM-HP4-S	Swivel	4,000 lbs.	22 lbs.
LM-HP4-R	Rigid	4,000 lbs.	22 lbs.
LM-HP6-S	Swivel	6,000 lbs.	22 lbs.
LM-HP6-R	Rigid	6,000 lbs.	22 lbs.

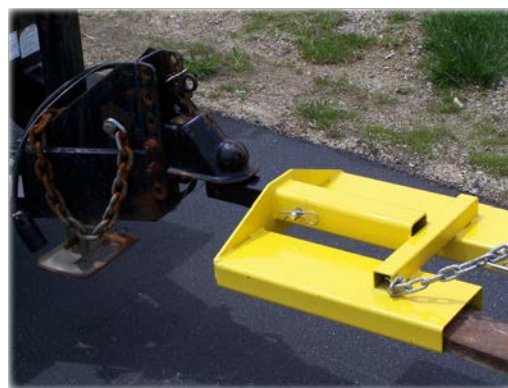

FORK TRUCK HITCH ADAPTER

With 1-7/8" ball the operator can safely and easily move trailers and other equipment with just a fork lift. Adapter slides onto the existing forks and can accommodate ball, pintle or combination hitches. Trailer hitch, ball, and chain included.

PART #	BALL DIAMETER	WLL
DNFHA	1-7/8"	5,000 lbs.



RT-60



RT-40



RT-20



THE "REEL THING"

A dependable, easy to use cable reel lifter for use in the warehouse or field.

PART #	ARBOR HOLE	CAPACITY	WEIGHT
RT-20	2" - 4"	3,000 lbs.	6 lbs.
RT-40	3" - 6"	4,500 lbs.	12 lbs.
RT-60	2-5/8" - 6"	12,000 lbs.	38 lbs.

NYLON SLINGS



Choker



Vertical



Basket



TWO PLY ENDLESS NYLON SLINGS

These polyester slings produce less stretch for increased load management. The Tuff-Tag provides all the required OSHA information. Please specify length when ordering.

PART #	WIDTH	RATED CAPACITY		
		VERTICAL	CHOKER	BASKET
EN2-801	1"	6,200 lbs.	4,900 lbs.	12,400 lbs.
EN2-802	2"	12,200 lbs.	9,800 lbs.	24,400 lbs.
EN2-803	3"	16,300 lbs.	13,000 lbs.	32,600 lbs.
EN2-804	4"	20,700 lbs.	16,500 lbs.	41,400 lbs.
EN2-806	6"	28,600 lbs.	23,000 lbs.	57,200 lbs.



Flat Eyes



Twisted Eyes

TWO PLY EYE TO EYE NYLON SLINGS

Internal red yarns aid in the inspection process. The tuff-tag provides all required OSHA information. The nylon stretches to help avoid shock loading. Specify length when ordering.

PART #	WIDTH	RATED CAPACITY		
		VERTICAL	CHOKER	BASKET
EE2-801	1"	3,200 lbs.	2,500 lbs.	6,400 lbs.
EE2-802	2"	6,400 lbs.	5,000 lbs.	12,800 lbs.
EE2-803	3"	8,600 lbs.	6,900 lbs.	17,200 lbs.
EE2-804	4"	11,500 lbs.	9,200 lbs.	23,000 lbs.
EE2-806	6"	16,300 lbs.	13,000 lbs.	32,600 lbs.

Other ply thicknesses available. For twisted eyes, add a "T" suffix to the part number. Eye to eye slings are also available with hardware attached to the eyes.

NYLON SLINGS



ROUNDSLINGS

Polyester load yarns protected by a double wall jacket. The wear points can be shifted to extend the life of the sling. Color-coded along industry standards. The Tuff-Tag provides all required OSHA information. Specify length when ordering.

PART #	COLOR	RATED CAPACITY		
		VERTICAL	CHOKER	BASKET
EN30	Purple	2,600 lbs.	2,100 lbs.	5,200 lbs.
EN60	Green	5,300 lbs.	4,200 lbs.	10,600 lbs.
EN90	Yellow	8,400 lbs.	6,700 lbs.	16,800 lbs.
EN120	Tan	10,600 lbs.	8,500 lbs.	21,200 lbs.
EN150	Red	13,200 lbs.	10,600 lbs.	26,400 lbs.
EN180	White	16,800 lbs.	13,400 lbs.	33,600 lbs.
EN240	Blue	21,200 lbs.	17,000 lbs.	42,400 lbs.
EN360	Grey	31,000 lbs.	24,800 lbs.	62,000 lbs.
EN600	Brown	53,000 lbs.	42,400 lbs.	106,000 lbs.
EN800	Olive	66,000 lbs.	52,800 lbs.	132,000 lbs.
EN1000	Black	90,000 lbs.	72,000 lbs.	180,000 lbs.

SUPER STRONG SCREW PIN ANCHOR SHACKLES

Manufactured from technically advanced micro alloy steel with optimal hardness for strength and ductility. Available finishes include powder coated, galvanized or self-colored.

PART #	SIZE	WLL
M645G	3/16"	1/2 Ton
M646G	1/4"	3/4 Ton
M647G	5/16"	1 Ton
M648G	3/8"	1-1/2 Tons
M649G	7/16"	2 Tons
M650G	1/2"	3 Tons
M651G	5/8"	4-1/2 Tons
M652G	3/4"	6-1/2 Tons
M653G	7/8"	8-1/2 Tons
M654G	1"	10 Tons
M655G	1-1/8"	12 Tons
M656G	1-1/4"	14 Tons
M666G	1-3/8"	17 Tons
M657G	1-1/2"	20 Tons



NYLON SLINGS

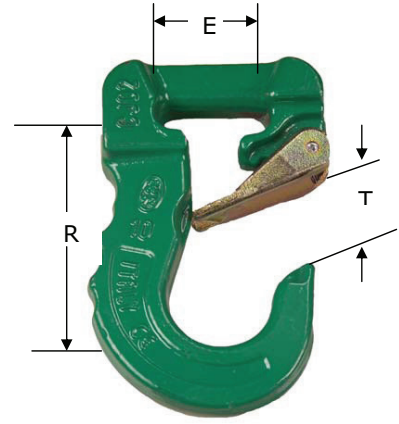

DIRECT CONNECT HOOKS

PART #	COLOR	RATED CAPACITY	TUFLEX	WEB SLINGS		WEIGHT	E	R	T
				WIDTH	PLIES				
DCH1	Purple	2,600 lbs.	EN30	1	1	1.5 lbs.	1-9/16"	3-3/8"	1"
DCH2	Green	5,300 lbs.	EN60	1	2	2.7 lbs.	1-3/4"	4"	1-5/16"
DCH3	Yellow	8,400 lbs.	EN90	2	1 & 2	4.9 lbs.	2-3/16"	4-5/8"	1-1/2"
DCH4	Red	13,200 lbs.	EN150	-	-	9.9 lbs.	2-3/4"	5-3/4"	1-3/4"

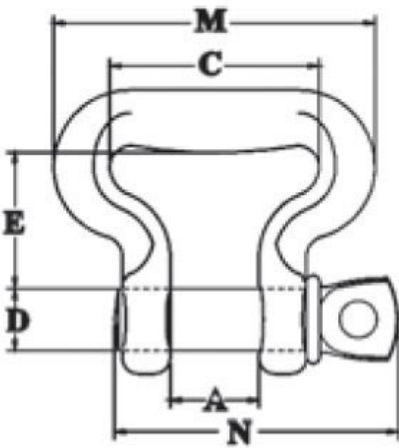

SLING SAVER

PART #	ROUND SLING SIZE #	SLING INFO					DIMENSIONS						
		WEBBING WIDTH	EYE WIDTH	PLY	WLL (TON)	WEIGHT EACH	A	C	D	E	K	M	N
1021048	1 & 2	2"	2"	2	2.95	1.2 lbs.	1.05"	2.5"	.75"	1.6"	1.22"	3.84"	3.35"
1021057	3	3"	1.375"	2	4.08	1.5 lbs.	1.25"	2"	.88"	1.5"	1.4"	3.38"	4"
1021066	4	4"	2"	2	5.67	2.5 lbs.	1.44"	2.5"	1"	2"	41.1"	4.21"	4.5"
1021075	5 & 6	6"	3"	2	7.70	4.3 lbs.	1.68"	3.6"	1.12"	2.75"	1.6"	5.62"	5.11"

WIRE ROPE SLINGS

Wire rope slings are available in two different classes. The 6 x 37 stranding is generally more flexible. Order slings in one foot increments at the end of the part number.

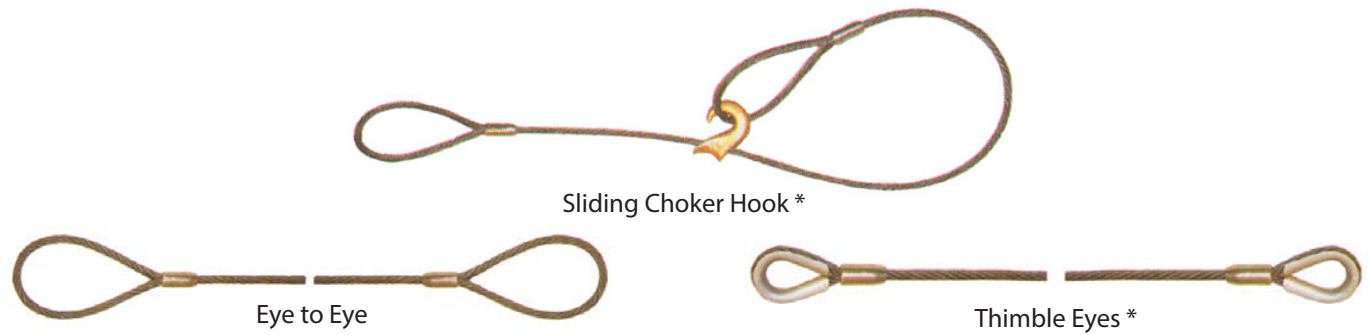

6 x 19 IWRC STRAND

* Eye to eye style is standard. Specify if thimble eyes or sliding choker hook are required. Other diameters and attachments are available. Call Tallman for more information.

DIAMETER	PART #	RATED CAPACITY (TONS)		
		VERTICAL	CHOKER	BASKET
1/4"	CS1904	.65	.48	1.3
5/16"	CS1905	1.0	.74	2.0
3/8"	CS1906	1.4	1.1	2.9
7/16"	CS1907	1.9	1.4	3.9
1/2"	CS1908	2.5	1.9	5.1
9/16"	CS1909	3.2	2.4	6.4
5/8"	CS1910	3.9	2.9	7.8
3/4"	CS1912	5.6	4.1	11
7/8"	CS1914	7.6	5.6	15
1"	CS1916	9.8	7.2	20
1-1/8"	CS1918	12	9.1	24

6 x 37 IWRC STRAND

DIAMETER	PART #	RATED CAPACITY (TONS)		
		VERTICAL	CHOKER	BASKET
3/8"	CS3706	1.4	1.1	2.9
7/16"	CS3707	1.9	1.4	3.9
1/2"	CS3708	2.5	1.9	5.1
9/16"	CS3709	3.2	2.4	6.4
5/8"	CS3710	3.9	2.9	7.8
3/4"	CS3712	5.6	4.1	11
7/8"	CS3714	7.6	5.6	15
1"	CS3716	9.8	7.2	20
1-1/8"	CS3718	12	9.1	24
1-1/4"	CS3720	15	11	30
1-3/8"	CS3722	18	13	36
1-1/2"	CS3724	21	16	42

TRANSFORMER SLINGS

Each sling is manufactured with Samson Rope and proof tested and tagged by a certified rope specialist.



ADJUSTABLE TRANSFORMER SLINGS

Tallman Equipment transformer slings are adjustable from 24" to 48" in length and the eyes are adjustable from 3" to 15". Each sling is proof tested and tagged by a Tallman Equipment certified rope specialist. Each tag includes: part number, rope diameter, working load limit, safe handling instructions, serial number and test date.

PART #	COLOR	WLL
DNTS12	Blue	1,225 lbs.
DNTS58	Red	2,160 lbs.
DNTS34	Green	3,200 lbs.

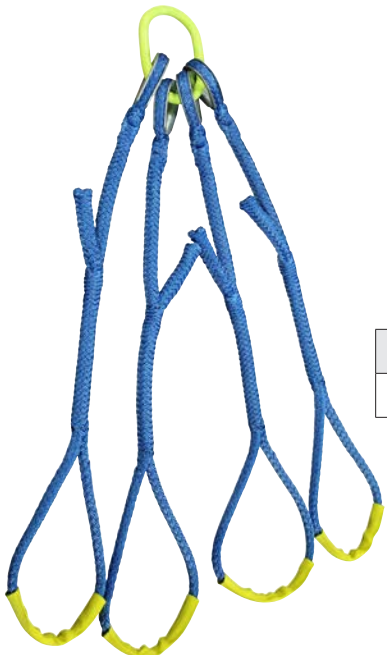

CAPACITOR BANK TRANSFORMER SLING

Legs are assembled with thimbles in each eye and connecting links on the lower end. Each leg is individually connected to the upper connecting link for maximum life and durability. Easily repaired if one leg becomes damaged.

PART #	LIFTING LEG LENGTH	WLL	WEIGHT
DNTS12CB-4-HD	Adjustable 34"- 44"	5,000 lbs.	7 lbs.

TRANSFORMER SLINGS

Each sling is manufactured with Samson Rope and proof tested and tagged by a certified rope specialist.

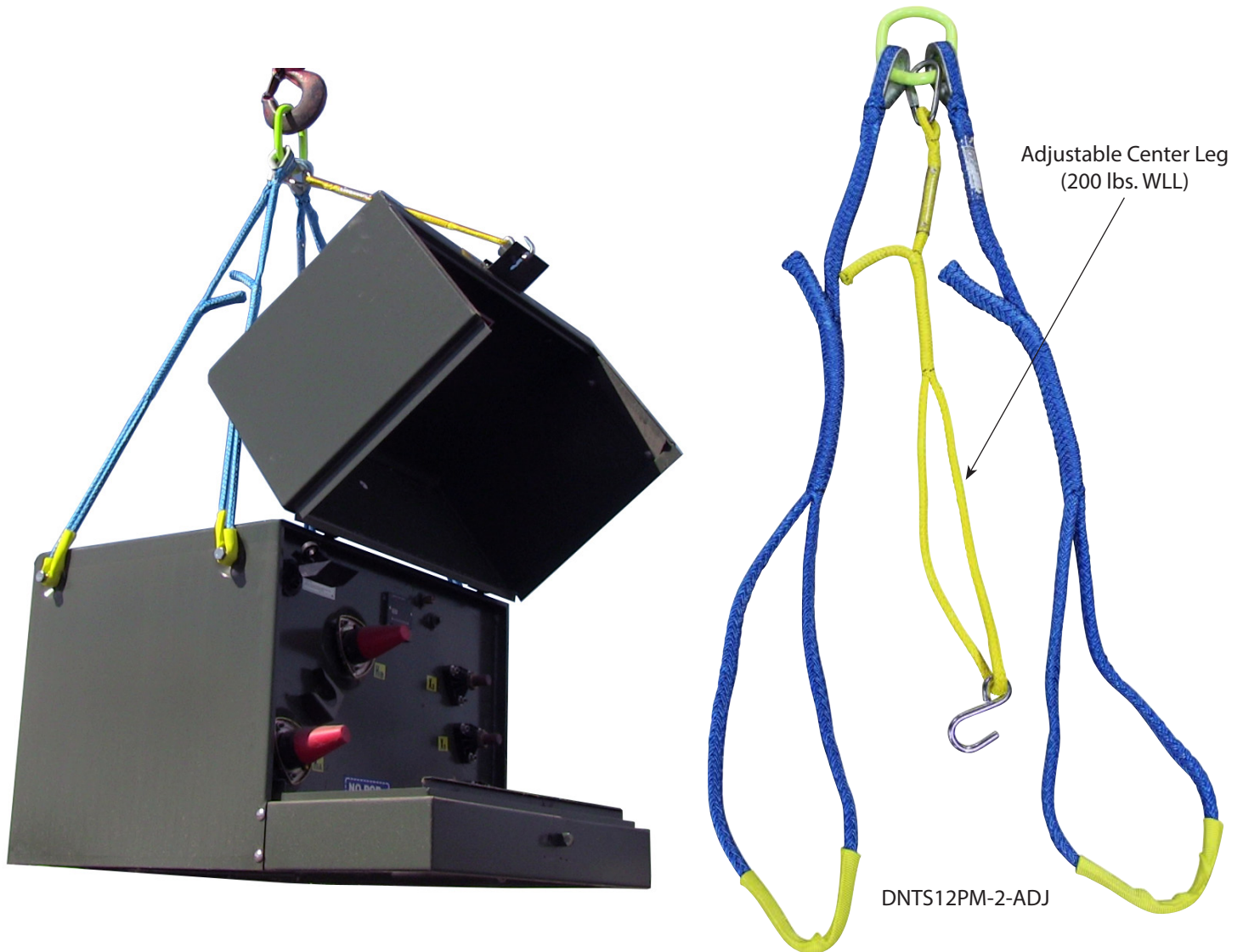

DNTS12PM-2-ADJ

Tags are encased in shrink wrap with part number, rope diameter, working load limit, technician's initials, serial number & test date.

SINGLE PHASE PADMOUNT TRANSFORMER SLING

Designed to easily handle single phase padmount transformers.
Adjustable and fixed length legs available with a center leg for holding the lid open.

PART #	NUMBER OF LEGS	LIFTING LEG LENGTH	WLL	WEIGHT
DNTS12PM-2-LL	2	Fixed 4'	2,500 lbs.	5 lbs.
DNTS12PM-2-ADJ-LL	2	Adjustable 3'- 4'	2,500 lbs.	5 lbs.
DNTS12PM-4-LL	4	Fixed 4'	5,000 lbs.	8 lbs.
DNTS12PM-4-ADJ-LL	4	Adjustable 3'- 4'	5,000 lbs.	9 lbs.

TRANSFORMER SLINGS

Each sling is manufactured with Samson Rope and proof tested and tagged by a certified rope specialist.



DNTS58PM-4-ADJ



DNTS34PM-4-HD

ADJUSTABLE & FIXED THREE PHASE PADMOUNT TRANSFORMER SLINGS

Legs are individually connected to the upper connecting link with thimbles in each eye for maximum life and durability. Lower eyes have wear pads. Easily repaired if one leg becomes damaged. Includes 10" x 19" mesh bag for storage.

PART #	LIFTING LEG LENGTH	WLL	WEIGHT
DNTS58PM-4	Fixed	12,000 lbs.	16 lbs.
DNTS58PM-4-ADJ	Adjustable 5' - 8'	12,000 lbs.	17 lbs.
DNTS34PM-4	Fixed	17,000 lbs.	22 lbs.
DNTS34PM-4-ADJ	Adjustable 5' - 8'	17,000 lbs.	23 lbs.

HEAVY-DUTY THREE PHASE PADMOUNT TRANSFORMER SLING

Legs are assembled with thimbles in each eye and connecting links on the lower end. Each leg is individually connected to the upper connecting link for maximum life and durability. Easily repaired if one leg becomes damaged. Includes 10" x 19" mesh bag for storage.

PART #	LIFTING LEG LENGTH	WLL	WEIGHT
DNTS34PM-4-HD	Fixed	17,000 lbs.	26 lbs.

POLE PULLING & SETTING



PULLING EYE

Adjusts from 1/2" to 1". WLL 6,000 lbs. Ultimate 30,000 lbs.

PART #	DESCRIPTION
DNPE-1	Pulling eye assembly
DNPE-1W	Replacement wedge



HEAVY DUTY PULLING EYE

This pulling eye can be used for loads up to 15,000 lbs.
Ultimate 60,000 lbs.

PART #	FITS ANCHOR ROD SIZE
DNHDPE-1000	1"
DNHDPE-1250	1-1/4"
DNHDPE-1500	1-1/2"
DNHDPE-1750	1-3/4"
DNHDPE-2000	2"
DNHDPE-2250	2-1/4"



CHAIN SLINGS

Made to order 100 grade chain link slings.
Chain sizes from 7/32" to 1-1/4" with a variety
of lengths and attachments available.

PART #	SIZE	LENGTH	WLL
CO06-4	3/8"	4'	8,800 lbs.
CO06-5	3/8"	5'	8,800 lbs.
CO06-6	3/8"	6'	8,800 lbs.
CO08-4	1/2"	4'	15,000 lbs.
CO08-5	1/2"	5'	15,000 lbs.
CO08-6	1/2"	6'	15,000 lbs.



CHAIN POLE SLINGS

Made with 100 grade chain and
a sliding choker hook, these slings are ideal
for handling large transmission poles.

PART #	CHAIN LENGTH	WLL
CPS384	4'	7,100 lbs.
CPS385	5'	7,100 lbs.
CPS386	6'	7,100 lbs.



PULLING HOOK

PART #	LENGTH
9055	10-1/2"
9062	15-1/2"

CHAIN HOISTS

TB602-5



TOOL BOX HOIST

PART #	RATED CAPACITY	STANDARD LIFT
TB602-5	550 lbs.	5'
TB602-10	550 lbs.	10'
TB603-5	1,100 lbs.	5'
TB603-10	1,100 lbs.	10'

LSB-1500B-5



STEEL BODY LINK CHAIN HOISTS

Their compact design makes these hoists extremely portable and easy to rig. A double reduction gearing system results in easy operation and minimal handle effort. The enclosed disc-type load brake provides positive load holding and positioning.

PART #	RATED CAPACITY	STANDARD LIFT	HANDLE LENGTH	WEIGHT
LSB-1500B-5	3/4 Ton	5'	9-1/4"	12 lbs.
LSB-1500B-10	3/4 Ton	10'	9-1/4"	14 lbs.
LSB-3000B-5	1-1/2 Tons	5'	14-9/16"	21 lbs.
LSB-3000B-10	1-1/2 Tons	10'	14-9/16"	24 lbs.
LSB-6000B-5	3 Tons	5'	14-9/16"	35 lbs.
LSB-6000B-10	3 Tons	10'	14-9/16"	40 lbs.
LSB-12000B-5	6 Tons	5'	14-9/16"	67 lbs.
LSB-12000B-10	6 Tons	10'	14-9/16"	77 lbs.

Other chain lifts available.

RA-20



RA MODEL LINK CHAIN HOISTS

These aluminum ratchet lever hoists with link type chain are ideal for transmission and distribution applications. The handle length for these hoists is 20-1/2" and the standard lift is 5' Extra chain is available.

PART #	RATED CAPACITY	HANDLE PULL AT RATED LOAD	WEIGHT
RA-15	3/4 Ton	59 lbs.	12.25 lbs.
RA-20	1 Ton	79 lbs.	12.25 lbs.
RA-15-2	1-1/2 Tons	60 lbs.	18 lbs.
RA-30	1-1/2 Tons	82 lbs.	23 lbs.
RA-40	2 Tons	109 lbs.	23 lbs.
RA-30-2	3 Tons	93 lbs.	35 lbs.
RA-30-3	4-1/2 Tons	96 lbs.	53 lbs.
RA-30-4	6 Tons	97 lbs.	63 lbs.

CHAIN HOISTS

The LB Series of lever hoists offers a low headroom, compact design that is perfect for use in tight quarters.

3/4-3 TON SINGLE CHAIN

PART #	RATED CAPACITY	STANDARD LIFT	WEIGHT
LB008-5	3/4 Ton	5'	13 lbs.
LB008-10	3/4 Ton	10'	15.5 lbs.
LB008-15	3/4 Ton	15'	18 lbs.
LB010-5	1 Ton	5'	13 lbs.
LB010-10	1 Ton	10'	15.5 lbs.
LB010-15	1 Ton	15'	18 lbs.
LB015-5	1-1/2 Tons	5'	18 lbs.
LB015-10	1-1/2 Tons	10'	21.5 lbs.
LB015-15	1-1/2 Tons	15'	25 lbs.
LB020-5	2 Tons	5'	25 lbs.
LB020-10	2 Tons	10'	30.5 lbs.
LB020-15	2 Tons	15'	36 lbs.
LB028-5	2-3/4 Tons	5'	25 lbs.
LB028-10	2-3/4 Tons	10'	30.5 lbs.
LB028-15	2-3/4 Tons	15'	36 lbs.
LB030-5	3 Tons	5'	33 lbs.
LB030-10	3 Tons	10'	40.5 lbs.
LB030-15	3 Tons	15'	50 lbs.

LB008-5



6 TON DOUBLE CHAIN

PART #	RATED CAPACITY	STANDARD LIFT	WEIGHT
LB060-5	6 Tons	5'	57 lbs.
LB060-10	6 Tons	10'	73 lbs.
LB060-15	6 Tons	15'	89 lbs.

LB060-5

LB090-5



9 TON TRIPLE CHAIN

PART #	RATED CAPACITY	STANDARD LIFT	WEIGHT
LB090-5	9 Tons	5'	88 lbs.
LB090-10	9 Tons	10'	111.5 lbs.
LB090-15	9 Tons	15'	135 lbs.

CHAIN HOISTS

ASK ABOUT OUR HOIST RENTALS

ALUMINUM BODY LINK CHAIN HOISTS

The lightweight, high-strength handle and housing are made of heat-treated aluminum. The chain is a high-strength alloy steel, polished for smooth action and low wear. All models are proof-tested at 150% of their rated capacity and have a standard 5' lift.

PART #	RATED CAPACITY	HANDLE PULL AT RATING	WEIGHT
C309-0438	3/4 Ton	65 lbs.	14 lbs.
3011S	1 Ton	90 lbs.	14 lbs.
C309-0439	1-1/2 Tons	60 lbs.	22 lbs.
4012	2 Tons	90 lbs.	28.5 lbs.
C309-0440	3 Tons	60 lbs.	30.5 lbs.
C309-0441	4-1/2 Tons	70 lbs.	47 lbs.
C309-0442	6 Tons	70 lbs.	50 lbs.



3011S

C309-0440

G MODEL ROLLER CHAIN HOISTS

With malleable iron roller chain and handles, these are the most durable hoists on the market. Additional chain can be spliced to increase the lift.

PART #	RATED CAPACITY	STANDARD LIFT	# OF LOAD CHAINS	HANDLE LENGTH	WEIGHT
AG	3/4 Ton	56-1/2"	1	18-3/4"	14 lbs.
ATG	1-1/2 Tons	57"	2	18-3/4"	17 lbs.
FG	1-1/2 Tons	56-1/2"	1	27-5/8"	25 lbs.
FTG	3 Tons	57"	2	27-5/8"	34 lbs.
ZG-4-1/2	4-1/2 Tons	53"	3	33-5/8"	49 lbs.
ZG-6	6 Tons	53"	4	33-5/8"	59 lbs.
WG-9	9 Tons	60"	5	33-5/8"	120 lbs.
WG-11	11 Tons	60"	6	33-5/8"	130 lbs.
WG-13	13 Tons	60"	7	33-5/8"	140 lbs.
WG-15	15 Tons	60"	8	33-5/8"	150 lbs.

AG, ATG, FG & FTG models are available with a "Double Locking Pawl" design. The double locking pawl allows the load to be raised or lowered with a half stroke of the handle. Add the suffix "I" to the end of the part number.



ATG

STRAP HOISTS

Double interlocking pawls assures that one pawl is engaged at all times for positive load holding. Except for the 6000 series, the fiberglass handles have an overload feature. The replaceable tips bend to alert the user of a possible overload. All hooks swivel 360° and are equipped with latches. A quick disconnect design of the sheave block allows for easy removal for single line use.

STRAP HOISTS WITH STANDARD HANDLES & HOOKS

PART #	SINGLE LINE CAPACITY	DOUBLE LINE CAPACITY	SINGLE LINE LIFT	DOUBLE LINE LIFT	WEIGHT
250A	1/2 Ton	1 Ton	9'	4-1/4'	11 lbs.
300A	3/4 Ton	1-1/2 Tons	9'	4-1/4'	11 lbs.
322B	3/4 Ton	1-1/2 Tons	14'	7'	12.5 lbs.
344B	1 Ton	2 Tons	11'	5-1/2'	13.5 lbs.
6000A	N/A	3 Tons	N/A	5'	25.5 lbs.

Specify special hooks or latches when ordering.

344B



6000DA



STRAP HOISTS WITH HOT STICK HANDLES & HOOKS

PART #	SINGLE LINE CAPACITY	DOUBLE LINE CAPACITY	SINGLE LINE LIFT	DOUBLE LINE LIFT	WEIGHT
250DA	1/2 Ton	1 Ton	9'	4-1/4'	11.5 lbs.
300DA	3/4 Ton	1-1/2 Tons	9'	4-1/4'	11.5 lbs.
322DB	3/4 Ton	1-1/2 Tons	14'	7'	11.5 lbs.
344DB	1 Ton	2 Tons	11'	5-1/2'	13 lbs.
6000DA	N/A	3 Tons	N/A	5'	25.5 lbs.

AVAILABLE HOOK OPTIONS



Standard hook



Hot stick hook



Swivel gate hook



Hot stick & gate latch hook

STRAP HOISTS

Strap hoists feature an exclusive breakable stress link which signals the operator of an overload condition by breaking before any load-carrying part of the hoist is seriously overloaded.

Standard hooks



STRAP HOISTS WITH STANDARD HOOKS & HANDLES

PART #	SINGLE LINE CAPACITY	DOUBLE LINE CAPACITY	SINGLE LINE LIFT	DOUBLE LINE LIFT	WEIGHT
2A	1/2 Ton	1 Ton	9' - 1"	3' - 11"	10.25 lbs.
3A	3/4 Ton	1-1/2 Tons	10' - 8"	4' - 11"	13 lbs.
4A	1 Ton	2 Tons	8' - 6"	3' - 10"	14.75 lbs.

STRAP HOISTS WITH HOT STICK HOOKS & HANDLES

PART #	SINGLE LINE CAPACITY	DOUBLE LINE CAPACITY	SINGLE LINE LIFT	DOUBLE LINE LIFT	WEIGHT
2B	1/2 Ton	1 Ton	9' - 1"	3' - 11"	10.25 lbs.
3B	3/4 Ton	1-1/2 Tons	10' - 8"	4' - 11"	13 lbs.
4B	1 Ton	2 Tons	8' - 6"	3' - 10"	14.75 lbs.

Hot stick rings & Hook latches



STRAP HOISTS WITH GATE HOOKS & STANDARD HANDLES

PART #	SINGLE LINE CAPACITY	DOUBLE LINE CAPACITY	SINGLE LINE LIFT	DOUBLE LINE LIFT	WEIGHT
2U	1/2 Ton	1 Ton	9' - 1"	3' - 11"	12 lbs.
3U	3/4 Ton	1-1/2 Tons	10' - 8"	4' - 11"	14.75 lbs.
4U	1 Ton	2 Tons	8' - 6"	3' - 10"	16.75 lbs.

STRAP HOISTS WITH GATE HOOKS & HOT STICK RINGS

PART #	SINGLE LINE CAPACITY	DOUBLE LINE CAPACITY	SINGLE LINE LIFT	DOUBLE LINE LIFT	WEIGHT
2UB	1/2 Ton	1 Ton	9' - 1"	3' - 11"	12 lbs.
3UB	3/4 Ton	1-1/2 Tons	10' - 8"	4' - 11"	14.75 lbs.
4UB	1 Ton	2 Tons	8' - 6"	3' - 10"	16.5 lbs.

Shown with conversion kit

STRAP HOISTS

Convertible Strap Hoists have all of the parts needed to change from double line to single line on the hoist, reducing the chance of losing parts. These models also feature the Stress Link.

CONVERTIBLE HOISTS WITH STANDARD HOOKS & HANDLES

PART #	SINGLE LINE CAPACITY	DOUBLE LINE CAPACITY	SINGLE LIFT LINE	DOUBLE LIFT LINE	WEIGHT
2CA	3/4 Ton	1-1/2 Tons	7' - 2"	3' - 6"	9.5 lbs.
3CA	3/4 Ton	1-1/2 Tons	11' - 1"	5' - 4"	13.25 lbs.
4CA	1 Ton	2 Tons	9' - 2"	4' - 5"	14.5 lbs.

Available with gate hooks with hot stick rings.

CONVERTIBLE HOISTS WITH HOT STICK HOOKS & HANDLES

PART #	SINGLE LINE CAPACITY	DOUBLE LINE CAPACITY	SINGLE LIFT LINE	DOUBLE LIFT LINE	WEIGHT
2CB	3/4 Ton	1-1/2 Tons	7' - 2"	3' - 6"	9.75 lbs.
3CB	3/4 Ton	1-1/2 Tons	11' - 1"	5' - 4"	13.5 lbs.
4CB	1 Ton	2 Tons	9' - 2"	4' - 5"	14.75 lbs.

Available with gate hooks with hot stick rings.

CONVERTIBLE HOISTS WITH GATE HOOKS & STANDARD HANDLES

PART #	SINGLE LINE CAPACITY	DOUBLE LINE CAPACITY	SINGLE LIFT LINE	DOUBLE LIFT LINE	WEIGHT
2CU	3/4 Ton	1-1/2 Tons	7' - 2"	3' - 5"	10 lbs.
3CU	3/4 Ton	1-1/2 Tons	11' - 1"	5' - 3"	13.75 lbs.
4CU	1 Ton	2 Tons	9' - 2"	4' - 4"	15 lbs.

Available with gate hooks with hot stick rings.



STRAP HOISTS



Standard hook



Hot stick hook



Swivel gate hook



Hot stick & gate latch hook



3W08S



30W08HB



2W10S

SPECIFY SPECIAL HOOKS OR LATCHES WHEN ORDERING.

These hoists have a double-flanged drum to keep the strap from making contact with the ratchet teeth and a breakable stress link alerting the user to a possible overload. Individually tested to 125% of the rated capacity. Models 30W08 and 30W08S are convertible from single to double rigged using easy pull lynch pins on both the pulley block and hoist frame.

PART #	HANDLE LENGTH	SINGLE LINE CAPACITY	DOUBLE LINE CAPACITY	SINGLE LINE LIFT	DOUBLE LINE LIFT	WEIGHT
2W10	30"	1/2 Ton	1 Ton	9'	4-1/2'	10.25 lbs.
2W10S	20"	1/2 Ton	1 Ton	9'	4-1/2'	10.25 lbs.
3W08	30"	3/4 Ton	1-1/2 Tons	7'	3-1/2'	10.25 lbs.
3W08S	20"	3/4 Ton	1-1/2 Tons	7'	3-1/2'	10.25 lbs.
30W08*	30"	3/4 Ton	1-1/2 Tons	7'	3-1/2'	10 lbs.
30W08S*	20"	3/4 Ton	1-1/2 Tons	7'	3-1/2'	10 lbs.
4W12	36"	1 Ton	2 Tons	10'	5'	14.75 lbs.

* Convertible model.

Add "B" to the part number for hot stick hooks. Add "HB" to the part number for hot stick hooks & latches.

Add "U" to the part number for gate hooks.

STRAP & ROPE HOISTS

CONVERTIBLE STRAP HOISTS

The heat-treated aluminum-alloy frame is of an open design for self-cleaning in mud or ice. The interlocking pawls allow for sure control without brakes that can slip. Standard lift on all models is 6' in single strap mode and 3' in double strap mode.

PART #	HOOK & HANDLE TYPE	CAPACITY SINGLE LINE	CAPACITY DOUBLE LINE	WEIGHT
PSC309-0451	Standard hooks & handle	3/4 Ton	1-1/2 Tons	12.5 lbs.
PSC309-0452	Hot stick hooks & handle	3/4 Ton	1-1/2 Tons	13.5 lbs.
PSC309-0663	All hot stick models	3/4 Ton	1-1/2 Tons	13.5 lbs.

PSC309-0452



NON-CONVERTIBLE STRAP HOISTS

All of these models come with Hot Stick Rings on the hooks and latches. The 1 Ton models have a single strap with a standard lift of 5' - 9" while the 2 Ton models have a double strap with a lift of 3' - 9".

PART #	HANDLE TYPE	CAPACITY	WEIGHT
PSC309-0323	Standard handle	1 Ton	12.75 lbs.
PSC309-0467	Hot stick handle	1 Ton	13.75 lbs.
PSC312-0000	Standard handle	2 Tons	14.5 lbs.
PSC309-0468	Hot stick handle	2 Tons	15.5 lbs.

PSC312-0000



LONG HAUL ROPE PULLERS

Since this unique tool can use any length of 1/2" rope, it has a virtually limitless pulling capacity. It's ideal for pulling a load up from the ground and pulling in lines. It has a 3/4 Ton lifting capacity and is supplied with 20 feet of 3 strand rope.

PART #
A-20

LINK STICKS



3414



C400-1175



C400-2399

LINK STICKS

1-1/4" diameter fiberglass poles with steel hook on one end and butt swivel on the other end. 4,000 lb. working load.

PART #	LENGTH BETWEEN FITTINGS	WEIGHT
3414	12"	2.5 lbs.
C400-1175	15"	4 lbs.
C400-2399	18"	5 lbs.
C400-2400	24"	6 lbs.



CROSSARM LINK STICK

Quickly puts insulated link in hoist-assisted jobs.

Features 1-1/4"-diameter Epoxiglas® pole with 21-1/2" insulating length, Plastisol-coated 3/4"-diameter steel hook. Hook's 5" opening fits standard 3-3/4" x 4-3/4" crossarms. Galvanized-steel swivel eye on pole end for easy alignment.

Lifting eye on hook fitting for positioning by a hot line tool.

PART #	RATED WORKING LOAD
PSC4004132	1,500 lbs.

CAPSTAN HOIST

This manual capstan hoist is the ultimate tool for lowering heavy loads in a safe and controlled fashion. The capstan has two settings, providing a 44:1 and a 22:1 mechanical advantage, and two specialized spools: one for lowering and one for lifting. It has a dead lift rating of 3,000 lbs. Accepts 1/2" to 3/4" diameter rope.



MANUAL CAPSTAN HOIST

Includes: mounting plate, 20' cinch strap, 36" tensioning bar, winch handle and harken 2-speed rope winch.

PART #	WLL	GROSS WEIGHT
GRCS1000-TMU	2,000 lbs.	80 lbs.

ACCESSORIES

PART #	DESCRIPTION
GRCS1000-TA	Optional truck mount assembly allows you to attach your capstan to your vehicle

CAPSTAN HOISTS (1,000 LB CAPACITY)

WE RENT CAPSTAN HOISTS.

Lightweight yet powerful, these portable hoists can get into remote or difficult access sites. They perform a variety of tasks such as pole setting, pulling wheeled equipment over obstacles, raising transformers, stringing and tensioning conductors, pulling cable, and much more. Control is so accurate, loads can be moved fractions of an inch.



C308-1170

1,000 LB. ELECTRIC CAPSTAN HOISTS

All electric capstan hoists are furnished with foot controls. The 12 VDC model comes with 25' of #2 Cu cable, 4 terminals, relay and the foot switch.

PART #	VOLTAGE	WEIGHT
C308-1170	115 VAC	49 lbs.
C308-1171	230 VAC	49 lbs.
C308-1172	12 VDC	56 lbs.

Operator effort remains low for typical loads simply by adding wraps on the capstan drum. 4 wraps of rope = 1:44 ratio. That is 1lb. pull on fall line develops 44 lbs. on load line. Therefore, 20 lbs. of pull develops 880 lbs. of lift.

NOTE:

ALWAYS USE AT LEAST AS MANY WRAPS OF ROPE ON THE DRUM TO LOWER A LOAD AS REQUIRED TO LIFT THAT LOAD.

PART #	ROPE SPEED FOR 1,000 LB. LOAD	SOURCE, MINIMUM
C308-1170	40 Feet per minute	14 Amperes motor current
C308-1171	21 Feet per minute	7 Amperes motor current
C308-1172	22 Feet per minute	90 Amperes motor current
C308-1180	93 Feet per minute	8 GPM & 1,000 PSI
C308-1190	40 Feet per minute	Engine speed 7,000 RPM



1,000 LB. HYDRAULIC CAPSTAN HOISTS

Equipped with 3/8" NPT flat face couplers and dust caps. Order foot control switch PART # C308-0685 separately.

PART #
C308-1180

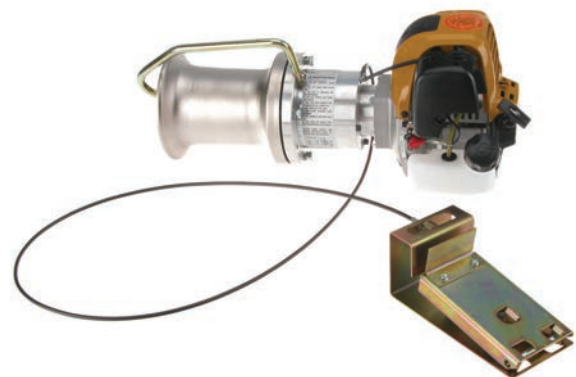

1,000 LB. GASOLINE DRIVE CAPSTAN HOISTS

Features a 35cc 4-cycle engine with foot throttle control. Mounting bracket # C308-0925 is recommended for this hoist.

PART #
C308-1190

1,000 LB. CAPSTAN HOIST ACCESSORIES

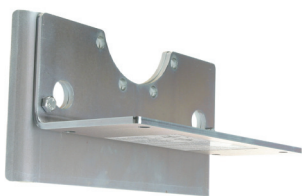

UNIVERSAL BRACKET

PART #
C308-0925



CHAIN CLAMP

85" chain clamp for C308-0925 bracket.

PART #
C417-0346



ROPE LOCK DEVICE

PART #
C308-0856



BOLT DOWN BRACKET

PART #
E308-1321P



72" CHAIN CLAMP

FE308-1321P or C308-1335.

PART #
E308-1334P



ALL-PURPOSE BRACKET

PART #
C308-1335



C-BRACKET

PART #
C308-0890



SWIVEL BRACKET

PART #
C308-0903



HITCH RECEIVER MOUNT

PART #
T308-0999



ELECTRIC FOOT CONTROL SWITCH

PART #
C417-0337



HYDRAULIC FOOT CONTROL SWITCH

PART #
C308-0685

CAPSTAN HOISTS (3,000 LB. CAPACITY)

WE RENT CAPSTAN HOISTS.

Lightweight yet powerful, these portable hoists can get into remote or difficult access sites. They perform a variety of tasks such as pole setting, pulling wheeled equipment over obstacles, raising transformers, stringing and tensioning conductors, pulling cable, and much more. Control is so accurate, loads can be moved fractions of an inch.



3000 LB. ELECTRIC CAPSTAN HOIST

115 VAC. Includes foot control switch.

PART #
C308-1370

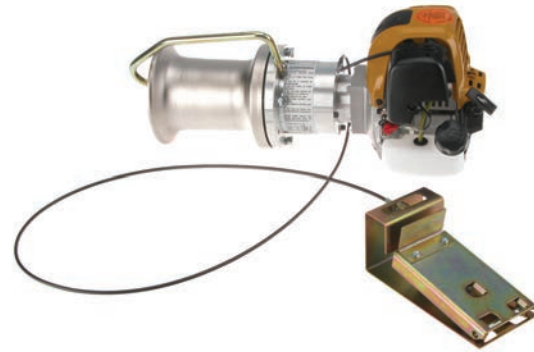

3000 LB. GASOLINE DRIVE CAPSTAN HOIST

Includes foot control switch and 35cc, 4-cycle engine.

PART #
C308-1390



3000 LB. HYDRAULIC CAPSTAN HOIST

Includes 3/8" flat face couplers. Foot control switch separately.

PART #
C308-1380



3000 LB. HYDRAULIC CAPSTAN HOIST

With bayonet adapter installed.

PART #
C308-0900

Operator effort remains low for typical loads simply by adding wraps on the capstan drum.

4 wraps of rope = 1:44 ratio.

That is 1lb. pull on fall line develops 44 lb. on load line.

Therefore 20 lbs. of pull develops 880 lbs. of lift.

NOTE:

ALWAYS USE AT LEAST AS MANY WRAPS OF ROPE ON THE DRUM TO LOWER A LOAD AS REQUIRED TO LIFT THAT LOAD.

PART #	ROPE SPEED FOR 1,000 LB. LOAD	SOURCE MINIMUM
C308-1370	12 Feet per minute	14 Amperes motor current
C308-1380	30 Feet per minute	8 GPM @ 1,000 PSI
C308-1390	11 Feet per minute	Engine speed 7,000 RPM

3 strand rope is recommended for use with capstan hoists.

See page 216 for more information.



3,000 LB. CAPSTAN HOIST ACCESSORIES



BOLT DOWN BRACKET

PART #

E308-1434P



72" CHAIN CLAMP

PART #

E308-1334P



ALL-PURPOSE BRACKET

PART #

C308-1443



ROPE LOCK DEVICE

PART #

C308-0856



REMOVABLE CAPSTAN DRUM

PART #

C417-0341



BAYONET ADAPTER

2-7/16" Diameter to retrofit 3,000 lb. hydraulic capstan to accept collapsible reel or capstan drum.

PART #

C308-0820



ELECTRIC FOOT CONTROL SWITCH

PART #

C417-0337



HYDRAULIC FOOT CONTROL SWITCH

PART #

C308-0685

WIRE PULLING GRIPS

WE RENT LARGE DIAMETER GRIPS.

All models are rated for a variety of wire sizes and types, so fewer grip changes are required. The notched handle locks the grip in the open position for placement on or removal from wire, then releases instantly. The spring loaded models allow a lineman to use a holding stick to open the gate and place the grip on the wire. When released, the gate closes and prevents the grip from falling off the wire.



LMG2000



LMG4500



LMG4900

STANDARD GRIPS - SPRING LOADED

PART #	CABLE DIAMETER	CAPACITY	WEIGHT
LMG1000 **	.04" - .394"	1,000 lbs.	.5 lb.
LMG2000 **	.109" - .594"	2,000 lbs.	1 lb.
LMG4500	.18" - .60"	5,000 lbs.	3.25 lbs.
LMG4600	.30" - .80"	10,000 lbs.	4.5 lbs.
LMG4800	.70" - 1.25"	12,000 lbs.	8 lbs.
LMG4700	.70" - 1.25"	20,000 lbs.	21 lbs.
LMG4900 ***	1.24" Aluminum - 1.8" Aluminum	20,000 lbs.	26 lbs.

** LMG1000 & LMG2000 both have bulldog-type jaws. All other models have parallel jaws.

*** LMG4900 should be used on aluminum conductor only.



Notched handle

LMG4501

HOT LINE GRIPS - SPRING LOADED & NOTCHED HANDLE

PART #	CABLE DIAMETER	CAPACITY	WEIGHT
LMG4501	.18" - .60"	5,000 lbs.	3.25 lbs.
LMG4601	.30" - .80"	10,000 lbs.	4.5 lbs.
LMG4801	.70" - 1.25"	12,000 lbs.	8 lbs.
LMG4701	.70" - 1.25"	20,000 lbs.	21 lbs.

Hot Line Grips are also available without springs or notched handles. Most grips are available with aggressive or fine teeth.

WIRE PULLING GRIPS

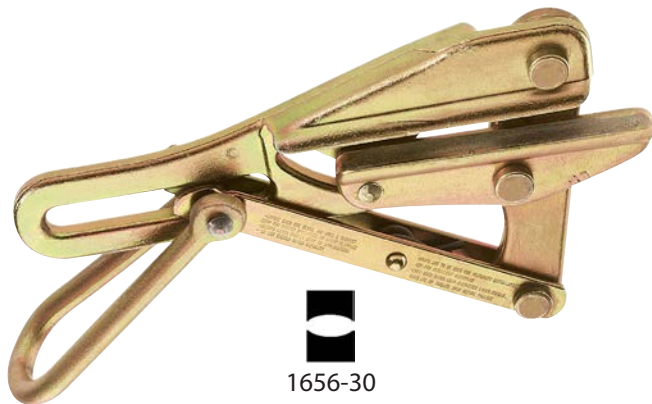

1656-30

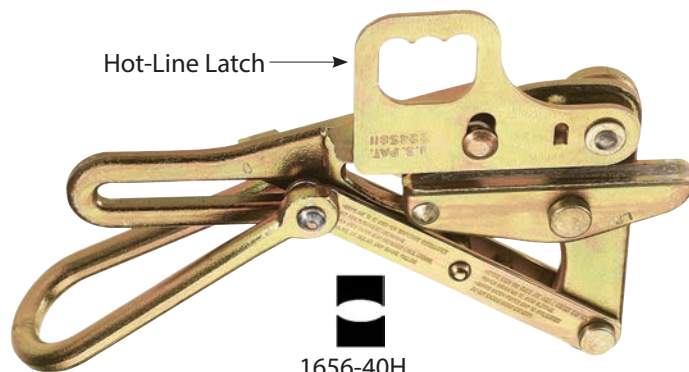

1656-40H

CHICAGO GRIPS FOR BARE ACSR, ALUMINUM & STRANDED COPPER

The round, smooth jaw contour is ideal for bare ACSR, aluminum and stranded-copper cables and is less likely to damage the conductor. The hot-line latch closes automatically to prevent the grip from disengaging from the wire.

PART #	CABLE DIAMETER	MAXIMUM SAFE LOAD	JAW LENGTH	WEIGHT
1656-20	.20" (# 6 ACSR) - .398" (1/0 ACSR)	4,500 lbs.	4"	3 lbs.
1656-30	.31" (# 2 ACSR) - .53"	4,500 lbs.	4-3/4"	3.75 lbs.
1656-40	.53" - .74" (336,400 ACSR)	8,000 lbs.	5-1/2"	8.30 lbs.
1656-50	.74" (397,500 ACSR) - .86" (477,000 ACSR)	8,000 lbs.	5-1/2"	8.30 lbs.
1656-60	.86" (477,000 ACSR) - .96" (605,000 ACSR)	8,000 lbs.	5-1/2"	8.20 lbs.

To order grips with the hot-line latch, add "H" to the end of the part number.



1628-50



1628-40

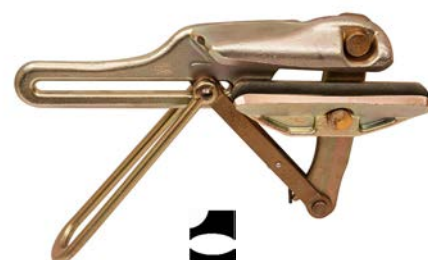

1628-40VR



Removable bolt on floating jaw, secured by a slotted nut and cotter pin. This jaw must be removed to insert the cable.

Machined upper and lower jaws eliminate scoring or damage to second conductor.

CHICAGO GRIPS FOR LARGE DIAMETER CONDUCTORS

The round jaws on these grips provide maximum contact with the cable virtually eliminating conductor damage.

PART #	CABLE DIAMETER*	MAXIMUM SAFE LOAD	JAW LENGTH	WEIGHT
1628-16P	.31" (# 2 ACSR) - .88" (477,000 ACSR)	15,000 lbs.	7-1/4"	17 lbs.
1628-30	.85" (477,000 ACSR) - 1.258" (1,033,500 ACSR)	20,000 lbs.	10-3/4"	27 lbs.
1628-40	1.24" (1,033,500 ACSR) - 1.54" (1,590,000 ACSR)	25,000 lbs.	10-3/4"	34 lbs.
1628-50	1.00" (666,600 ACSR) - 1.82" (2,500,000 ACSR)	25,000 lbs.	10-3/4"	34 lbs.
1628-30VR	1.079" - 1.140"	20,000 lbs.	10-3/4"	27 lbs.
1628-40VR	1.079" - 1.265"	25,000 lbs.	10-3/4"	34 lbs.

* The range of wire sizes that each grip can accommodate. Each grip is milled to one specific wire size within that range. Other sizes available. Call Tallman Equipment for more information.

WIRE PULLING GRIPS

WARNING

Do not exceed rated capacity.

Grips are to be used for temporary installation, not for permanent anchorage.

When used on or near energized lines, ground, insulate or isolate grip before pulling. Before each use, clean jaw area and inspect grip for proper operation to avoid slippage.



1678-30

CHICAGO GRIPS FOR ALUMINUM CONDUCTORS

Locking loop handles and spring allow the jaws to be held open for easier placement on the cable.

These lightweight grips are ideal for use on aluminum conductors. Hot-Line latches are available by special order.

PART #	CABLE DIAMETER	MAXIMUM SAFE LOAD	JAW LENGTH	WEIGHT
1678-20	.96" - 1.019"	8,000 lbs.	5-11/16"	8.30 lbs.
1678-30	1.040" - 1.063"	5,500 lbs.	5-11/16"	8.20 lbs.
1678-40	1.08" - 1.14"	5,500 lbs.	5-11/16"	8.20 lbs.
1678-50	1.162" - 1.196"	5,500 lbs.	5-11/16"	7.90 lbs.

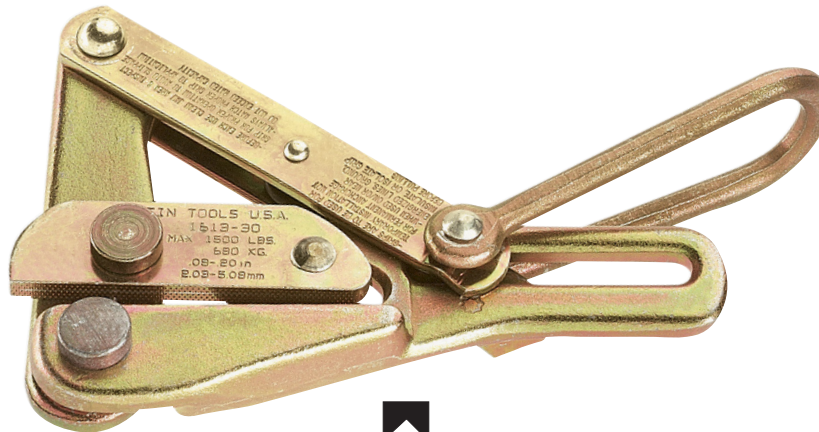

CHICAGO GRIPS FOR BARE WIRE

Lightweight and economical grip. The single "V" groove jaw is designed for working with solid and stranded bare wire.

PART #	CABLE DIAMETER	MAXIMUM SAFE LOAD	JAW LENGTH	WEIGHT
1613-30	.08" - .20"	1,500 lbs.	3"	1.50 lbs.

WIRE PULLING GRIPS

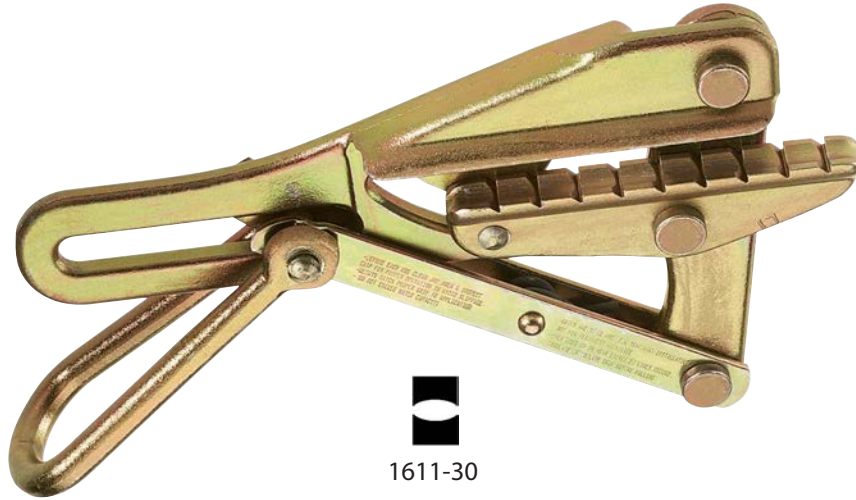

1611-30

CHICAGO GRIPS FOR WEATHERPROOF WIRE

Notches in the jaws provide a firm grip on insulation.

Due to various types of weatherproof coatings, the selection of the proper grip is determined by the outside diameter.

PART #	CABLE DIAMETER	MAXIMUM SAFE LOAD	JAW LENGTH	WEIGHT
1611-20	.20" - .40"	4,500 lbs.	4-3/16"	3 lbs.
1611-30	.31" - .53"	4,500 lbs.	4-3/4"	3.75 lbs.
1611-40	.53" - .74"	8,000 lbs.	5-11/16"	7.75 lbs.
1611-50	.74" - .86"	8,000 lbs.	5-11/16"	7.75 lbs.



1659-5AT



1684-5AT

CHICAGO GRIPS - BELL-SYSTEM TYPE GRIPS

The 1684-5AT is identical to the Bell-System type "L" strand puller and the 1628-16AT is identical to the "H" strand puller.

Equipped with chain, toggle and shackle. The Double "V" jaws assure proper alignment of the wire and jaws.

The 1659-5AT grip is similar to the Bell-System type "B" strand puller. The serpentine grooves provide excellent grip on strand preventing slippage. The round jaws provide maximum gripping power and reduced conductor damage.

PART #	CABLE DIAMETER	MAXIMUM SAFE LOAD	JAW LENGTH	WEIGHT
1684-5AT	.218" - .55"	8,000 lbs.	5"	6.90 lbs.
1628-16AT	.31" - .62"	15,000 lbs.	7-1/4"	15.80 lbs.
1692-5AT	.218" - .55"	8,000 lbs.	5"	6.60 lbs.
1659-5AT	.20" - .37"	5,000 lbs.	5"	6.70 lbs.

WIRE PULLING GRIPS

WARNING

Do not exceed rated capacity.

Grips are to be used for temporary installation, not for permanent anchorage. When used on or near energized lines, ground, insulate or isolate grip before pulling. Before each use, clean jaw area and inspect grip for proper operation to avoid slippage.



1672-10

PARALLEL JAW GRIPS

A longer jaw achieves a firm hold preventing slippage and damage to the cable. The latch helps to hold the cable position in the grip jaws. All have the double "V" jaws. Models 1686-20 & 1672-10 have knurled jaws.

PART #	CABLE DIAMETER	MAXIMUM SAFE LOAD	JAW LENGTH	WEIGHT
1686-10	.20" - .40"	10,000 lbs.	4-3/8"	5 lbs.
1686-20	.20" - .40"	10,000 lbs.	4-3/8"	5 lbs.
1671-10	.37" - .75"	10,000 lbs.	4-3/8"	5 lbs.
1672-10	.37" - .75"	10,000 lbs.	4-3/8"	5 lbs.



1659-30

CHICAGO GRIPS FOR PVC COVERED CONDUCTORS

The specially machined serpentine jaws allow the insulated conductor to be inserted through the jaws. Eliminating the need to strip off the insulation.

PART #	CABLE DIAMETER	MAXIMUM SAFE LOAD	JAW LENGTH	WEIGHT
1659-20	.20" - .42"	4,500 lbs.	4-3/16"	3 lbs.
1659-30	.31" - .50"	4,500 lbs.	4-3/4"	3.75 lbs.
1659-40	.49" - .79"	8,000 lbs.	5-11/16"	7.75 lbs.
1659-50	.79" - 1.01"	8,000 lbs.	5-11/16"	7.75 lbs.

WIRE PULLING GRIPS





1613-40



1684-5C



1684-5F
Replacement screws and file

CHICAGO GRIPS FOR EXTRA-HIGH STRENGTH CABLES, MESSENGER, GUY STRAND & CONDUCTORS

These grips reduce the chance of slipping and provide proper alignment of wire and cable.

PART #	CABLE DIAMETER	MAXIMUM SAFE LOAD	JAW LENGTH	WEIGHT
1613-40 **	.12" - .37"	4,500 lbs.	4-3/16"	3 lbs.
1684-5 **	.218" - .55"	8,000 lbs.	5"	6.25 lbs.
1692-5	.218" - .55"	8,000 lbs.	5"	6.40 lbs.
1684-5C	.16" - .55"	8,000 lbs.	5"	6.25 lbs.
1684-5F *	.16" - .55"	8,000 lbs.	5"	6.25 lbs.
1628-16	.31" - .62"	15,000 lbs.	7-1/4"	15.30 lbs.
1628-17	.50" - .75"	15,000 lbs.	7-1/4"	16.30 lbs.
1628-18	.75" - 1.00"	15,000 lbs.	7-1/4"	15.70 lbs.

* Similar to the 1684-5 but with a file inserted in the jaw for extra gripping power.
Replacement file PART # 578. Replacement screws PART # 573.

** Available with Hot-Line Latch. Add "H" to the end of the part number.



1684-74

CHICAGO GRIPS CURVED JAW FOR EHS CABLE

When pulling extra-high strength galvanized-steel cable, the galvanizing has a tendency to coat the jaws of any grip, causing the cable to slip. To reduce the possibility of slippage and damage to the cable, the jaws of this grip are milled on a curve with a double "V" contour.

PART #	CABLE DIAMETER	MAXIMUM SAFE LOAD	JAW LENGTH	WEIGHT
1684-74	.218" - .55"	8,000 lbs.	5"	6.30 lbs.
S1684-74H *	.218" - .55"	8,000 lbs.	5"	6.50 lbs.

* Hot-line latch and spring.

WIRE PULLING GRIPS

WARNING

Do not exceed rated capacity.

Grips are to be used for temporary installation, not for permanent anchorage. When used on or near energized lines, ground, insulate or isolate grip before pulling. Before each use, clean jaw area and inspect grip for proper operation to avoid slippage.



1685-20

PARALLEL JAW GRIPS

These lightweight and compact grips pull a wide range of cable sizes and types. The bottom jaw is serrated to firmly grip insulated cables and conductors. It's unique design includes a latch which prevents the grip from becoming disengaged from the cable.

PART #	CABLE DIAMETER	MAXIMUM SAFE LOAD	JAW LENGTH	WEIGHT
1685-20	.157" - .875"	4,500 lbs.	2.50"	3 lbs.
1685-31	.625" - 1.250"	7,500 lbs.	4.50"	5 lbs.



1604-20



1604-20L



1625-20

HAVEN'S GRIPS

Designed for use when a light compact grip is desired and where conductor damage is not a concern.

Model # 1604-20L and the 1625 series have a swing latch to hold the grip on the cable.

PART #	CABLE DIAMETER	MAXIMUM SAFE LOAD	WEIGHT
1604-10	.06" - .25"	2,500 lbs.	1 lbs.
1604-20	.125" - .50"	5,000 lbs.	2 lbs.
1604-20L	.125" - .50"	5,000 lbs.	2 lbs.
1625-20	.28" - .75" Wire rope	8,000 lbs.	4 lbs.
1625-20 7/8	.38" - .88" Wire rope	8,000 lbs.	4 lbs.
1625-20 1	.50" - 1" Wire rope	8,000 lbs.	4 lbs.

WIDE RANGE PARALLEL JAW GRIPS

Designed to accommodate a wider range of wire so that multiple grips are not required for multiple wire sizes.



KT4500

SPRING LOADED GRIPS

PART #	CABLE DIAMETER	MAXIMUM SAFE LOAD	JAW LENGTH	WEIGHT
KT4500	.180" - .600"	5,000 lbs.	3"	3.75 lbs.
KT4650	.160" - .900	5,000 lbs.	4-1/2"	4.4 lbs.
KT4600	.300" - .800"	10,000 lbs.	5"	7 lbs.
KT4800	.700" - 1.25"	12,000 lbs.	5-1/8"	9 lbs.

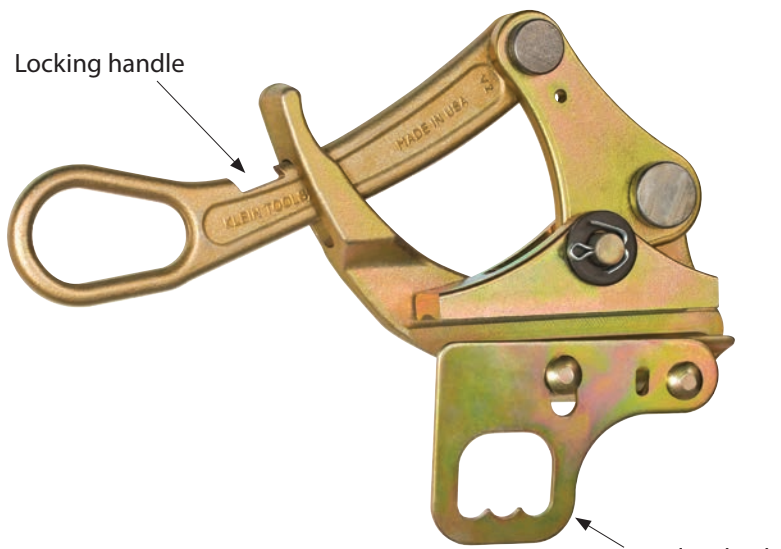

KT4501

SPRING LOADED GRIPS WITH HOT LATCH & LOCKING HANDLE

PART #	CABLE DIAMETER	MAXIMUM SAFE LOAD	JAW LENGTH	WEIGHT
KT4501	.180" - .600"	5,000 lbs.	3"	3.75 lbs.
KT4601	.300" - .800"	10,000 lbs.	5"	7 lbs.
KT4801	.700" - 1.25"	12,000 lbs.	5-1/8"	9 lbs.

WIRE PULLING GRIPS

WARNING

Do not exceed rated capacity.

Grips are to be used for temporary installation, not for permanent anchorage.

When used on or near energized lines, ground, insulate or isolate grip before pulling.
Before each use, clean jaw area and inspect grip for proper operation to avoid slippage.

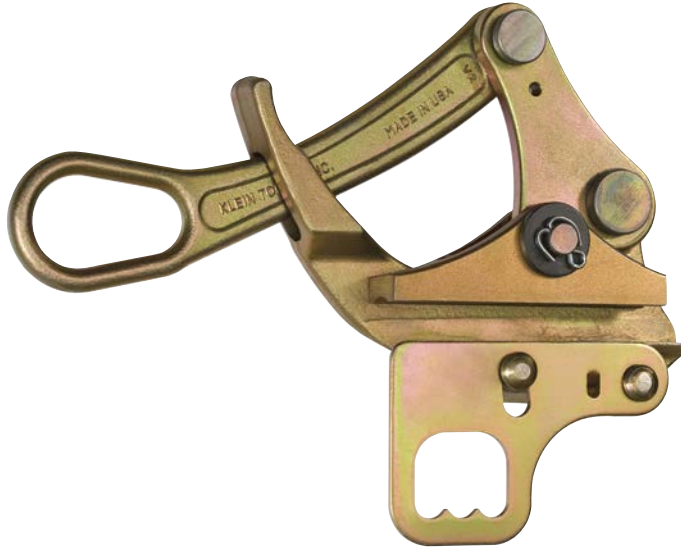

KT4502

GRIPS WITH HOT LATCH

PART #	CABLE DIAMETER	MAXIMUM SAFE LOAD	JAW LENGTH	WEIGHT
KT4502	.180" - .600"	5,000 lbs.	3"	3.75 lbs.
KT4602	.300" - .800"	10,000 lbs.	5"	7 lbs.
KT4802	.700" - 1.25"	12,000 lbs.	5-1/8"	9 lbs.



GRIP-CLEANING BRUSH SET

Set of four wire-bristle brushes for cleaning wire grips. 2 round and 2 square brushes on semi-flexible steel shafts.

PART #	DESCRIPTION	SIZE	LENGTH
25450	Round bristle	3/8" x 3"	12"
	Square bristle	3/8" x 3"	12"
	Round bristle	1-9/16" x 5"	14"
	Square bristle	1-9/16" x 5"	14"

WIRE PULLING GRIPS

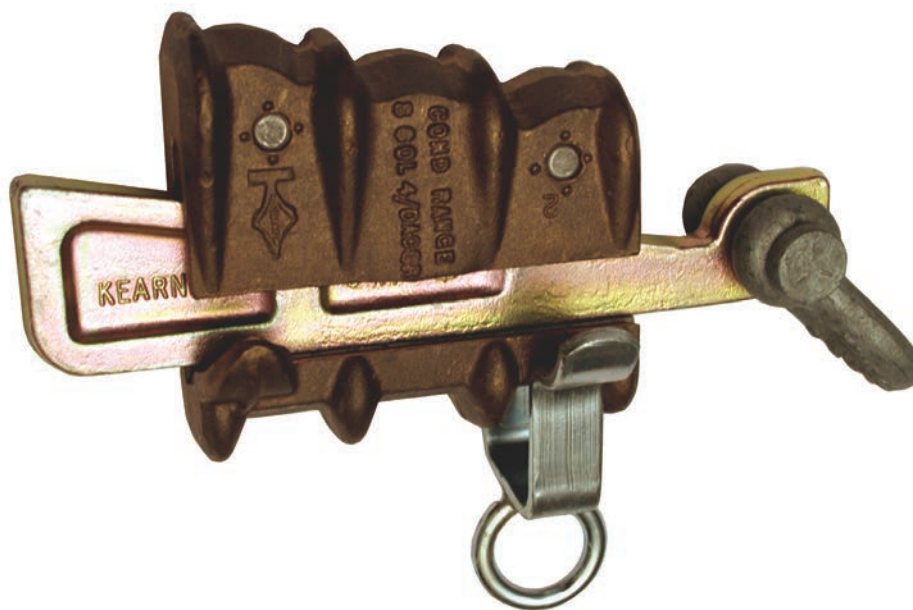

1833-3

WEDGE-TYPE GRIPS

The exclusive wedge-grip action provides a positive, tight grip on the conductor for a non-kinking, in-line pull. When installed, the safety latch drops over the conductor slot to keep the grip on the conductor.

LEFT HAND PART #	RIGHT HAND PART #	CABLE DIAMETER	CAPACITY
16847	16847-1	.128" - .292"	2,000 lbs.
1833-2	1833-3	.128" - .563"	6,000 lbs.
1833-4	1833-5	.258" - 1.050"	5,500 lbs.
1833-22	1833-21	.563" - 1.126"	5,500 lbs.

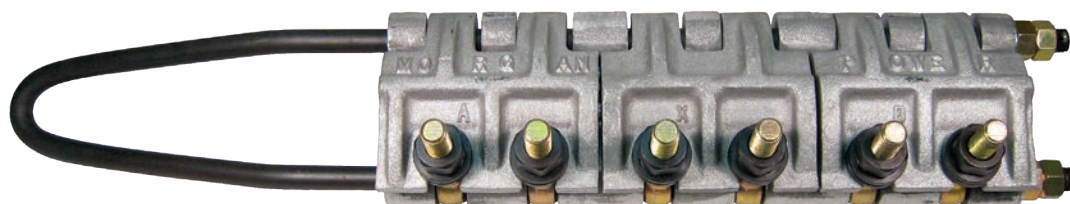

LH62-6

BOLTED-GRIPS (POCKETBOOK STYLE)

The body is a lightweight heat treated aluminum. Recommended for high voltage conductors. These grips are custom-bored to a specific conductor. Specify conductor type and diameter when ordering.

PART #	NUMBER OF BOLTS	CABLE DIAMETER	CAPACITY (ACSR)	CAPACITY (ACSS)	WEIGHT
LH62-6	6	3/8" - 1-1/4"	12,000 lbs.	9,000 lbs.	22 lbs.
LH62-8	8	3/4" - 2-1/2"	20,000 lbs.	15,000 lbs.	65 lbs.
LH62-16	16	3/4" - 2-1/2"	40,000 lbs.	30,000 lbs.	125 lbs.

WIRE PULLING GRIPS

TALLMAN RENTS SELF-CLAMPING GRIPS & LINERS.



SELF-CLAMPING GRIPS WITH INTERCHANGEABLE LINERS

Suitable for aluminum conductor, steel earth wire, anti-twisting rope and copper conductors. Made of high-tensile alloy steel, hot forged, heat-treated, precision machined and zinc plated with a complete range of interchangeable liners available.

PART #	MAXIMUM SAFETY LOAD	CABLE RANGE OPGW	CABLE DIAMETER	WEIGHT
IR3104-S	26,300 lbs.	--	.393" - 1.771"	37 lbs.



INTERCHANGEABLE LINERS

These aluminium interchangeable grip liners are inserted between the upper and lower jaws of the self-clamping grip bodies allowing for multiple wire sizes. Liners for copper conductors available upon request.

CABLE DIAMETER	PART #	CABLE DIAMETER	PART #
.393" - .413"	G4A-100F	1.003" - 1.063"	G4A-270F
.413" - .472"	G4A-105F	1.063" - 1.122"	G4A-285F
.472" - .531"	G4A-120F	1.122" - 1.181"	G4A-300F
.531" - .590"	G4A-135F	1.181" - 1.240"	G4A-315F
.590" - .649"	G4A-150F	1.240" - 1.299"	G4A-330F
.649" - .708"	G4A-165F	1.299" - 1.358"	G4A-345F
.708" - .767"	G4A-180F	1.358" - 1.417"	G4A-360F
.767" - .826"	G4A-195F	1.417" - 1.476"	G4A-375F
.826" - .885"	G4A-225F	1.476" - 1.535"	G4A-390F
.885" - .944"	G4A-240F	1.535" - 1.594"	G4A-410F
.944" - 1.003"	G4A-255F	1.594" - 1.771"	On specific diameter

WIRE PULLING GRIPS

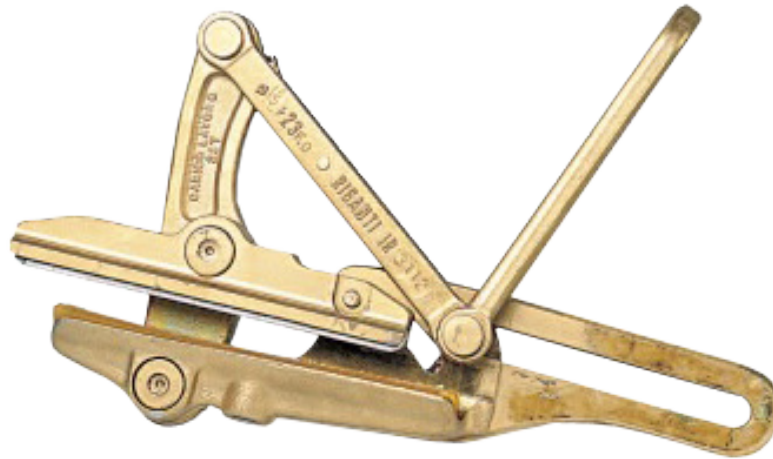

SELF-CLAMPING GRIPS WITH INTERCHANGEABLE LINERS FOR OPGW

Suitable for OPGW conductors, grip is made of tensile alloy steel, hot forged, heat-treated, precision machined and zinc plated with interchangeable liners to order. Order interchangeable liners specific to each conductor diameter.

Each set of liners includes an upper Teflon liner and a lower aluminum liner.

PART #	MAXIMUM SAFETY LOAD	CABLE RANGE OPGW	LINER TYPE	WEIGHT
IR3112	11,015 lbs.	0.24" - 0.91"	OPGW	15.5 lbs.

RENTAL EQUIPMENT

We rent the tools most commonly used in the construction and maintenance of electrical transmission and distribution systems.

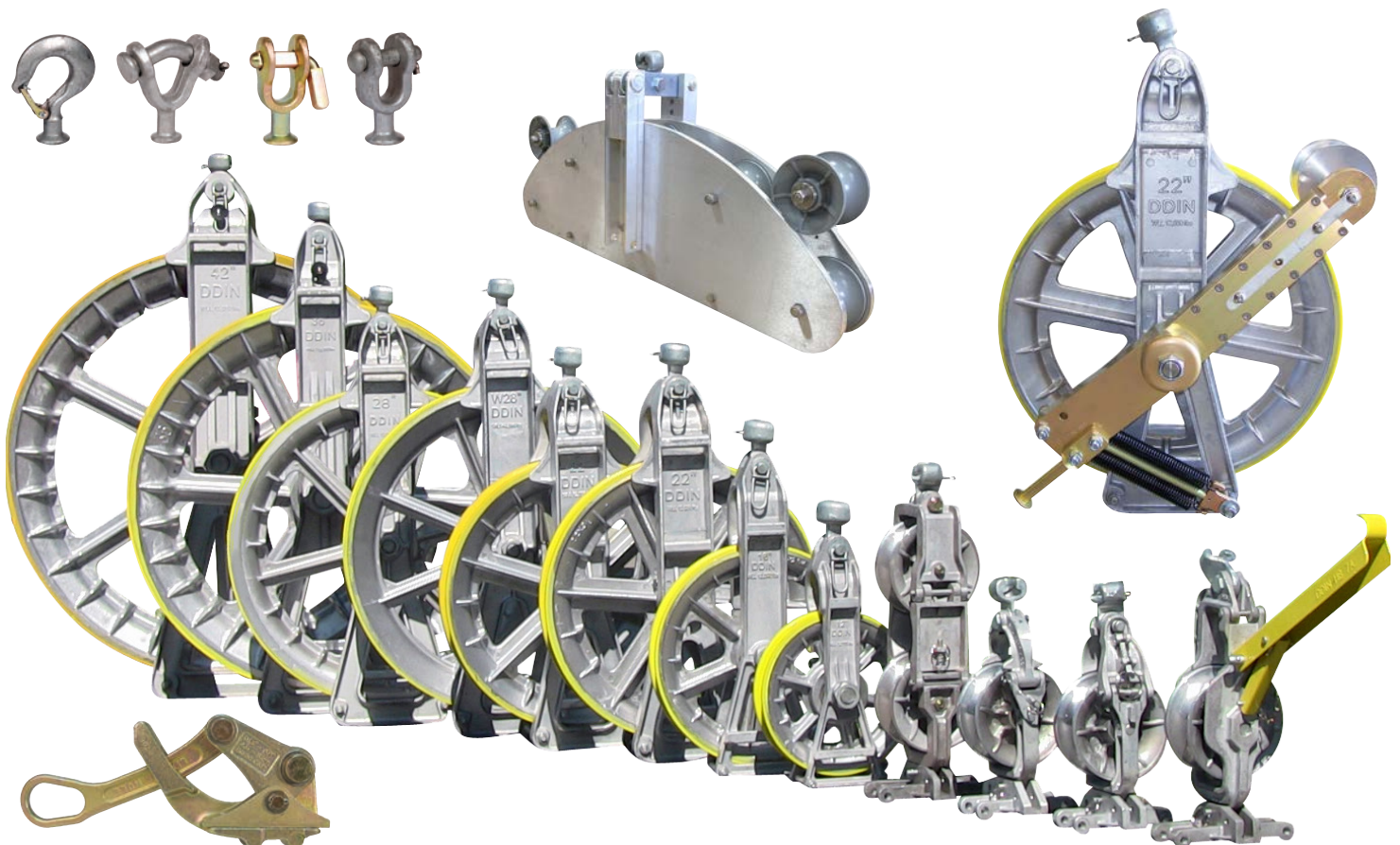

WIRE MESH PULLING GRIPS



MULTI WEAVE GRIPS - FLEXIBLE EYE

These grips are used primarily for pulling aluminum conductor and the triple weave construction is ideal for heavy loads.

PART #	CABLE DIAMETER RANGE	APPROXIMATE BREAK STRENGTH **	MESH LENGTH	COLOR
ZCS1710	.25" - .50"	7,000 lbs.	31"	Dark Green
ZCS1711	.50" - .75"	10,500 lbs.	45"	Brown
ZCS1712	.75" - 1.00"	14,100 lbs.	43"	Light Blue
ZCS1713	1.00" - 1.25"	25,000 lbs.	65"	Gold
ZCS1714	1.25" - 1.50"	31,000 lbs.	59"	Black
ZCS1715	1.50" - 1.75"	31,000 lbs.	82"	Red
ZCS1716	1.75" - 2.25"	49,000 lbs.	82"	Dark Blue
ZCS1750	2.00" - 2.50"	49,000 lbs.	72"	Yellow
ZCS1751	2.50" - 3.00"	49,000 lbs.	72"	Orange
ZCS1752	3.00" - 3.50"	49,000 lbs.	74"	Aluminum
ZCS1753	3.50" - 4.00"	49,000 lbs.	76"	Light Green

** The maximum recommended load is 20% of the approximate breaking strength based on a 5:1 safety factor.

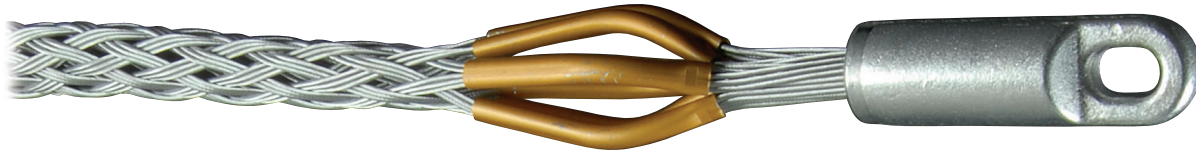

MULTI WEAVE GRIPS - REVOLVING EYE

The revolving eye is an alternative to the flexible wire rope eye and is designed for heavy duty applications.

PART #	CABLE DIAMETER RANGE	APPROXIMATE BREAK STRENGTH **	MESH LENGTH	COLOR
ZCS2177	.25" - .50"	7,000 lbs.	31"	Dark Green
ZCS2178	.50" - .75"	10,500 lbs.	45"	Brown
ZCS2179	.75" - 1.00"	14,100 lbs.	43"	Light Blue
ZCS2180	1.00" - 1.25"	25,000 lbs.	65"	Gold
ZCS2181	1.25" - 1.50"	31,000 lbs.	59"	Black
ZCS2182	1.50" - 1.75"	31,000 lbs.	82"	Red
ZCS2183	1.75" - 2.25"	43,000 lbs.	82"	Dark Blue
ZCS2779	2.00" - 2.50"	43,000 lbs.	72"	Yellow
ZCS2780	2.50" - 3.00"	43,000 lbs.	72"	Orange
ZCS2781	3.00" - 3.50"	43,000 lbs.	71"	Aluminum
ZCS2782	3.50" - 4.00"	43,000 lbs.	76"	Light Green

** The maximum recommended load is 20% of the approximate breaking strength based on a 5:1 safety factor.

WIRE MESH PULLING GRIPS



HIGH STRENGTH GRIPS - FLEXIBLE EYE

Used for pulling either aluminum conductor or synthetic rope, this is the strongest type of grip.
Feed tubes listed below are for inserting rope into the grips.

PART #	CABLE DIAMETER RANGE	ROPE DIAMETER RANGE	APPROXIMATE BREAK STRENGTH **	MESH LENGTH	COLOR
ZCS1799	.19" - .40"	.25" - .65"	7,000 lbs.	28"	Black
ZCS3020	.25" - .40"	.30" - .40"	10,000 lbs.	30"	Purple
ZCS1800	.40" - .63"	.50" - .90"	14,000 lbs.	41"	Dark Green
ZCS3522	.44" - .63"	.44" - .90"	20,000 lbs.	109"	Grey
ZCS1801	.63" - .88"	.75" - 1.10"	20,000 lbs.	58"	Red
ZCS1802	.88" - 1.13"	1.00" - 1.50"	30,700 lbs.	68"	Dark Blue
ZCS1803	1.13" - 1.38"	1.25" - 1.70"	47,000 lbs.	90"	Yellow
ZCS1804	1.38" - 1.92"	1.50" - 2.10"	65,000 lbs.	96"	Aluminum

** The maximum recommended load is 20% of the approximate breaking strength based on a 5:1 safety factor.



FEED TUBES

PART #	ROPE DIAMETER	LENGTH	FOR USE WITH GRIP #	COLOR
FTU1890	.25" - .65"	28"	ZCS1799	Black
FTU1891	.50" - .90"	40"	ZCS1800	Dark Green
FTU1892	.75" - 1.10"	52"	ZCS1801	Red
FTU1893	1.10" - 1.50"	67"	ZCS1802	Dark Blue
FTU1894	1.25" - 1.70"	83"	ZCS1803	Yellow
FTU1895	1.50" - 2.10"	96"	ZCS1804	Aluminum

WIRE MESH PULLING GRIPS

These grips are designed for pulling ACSR, bare aluminum or copper conductors, ground wires, messenger strands, wire ropes and insulated cables.



MULTIPLE STRENGTH GRIPS - FLEXIBLE EYE

PART #	CABLE DIAMETER RANGE	APPROXIMATE BREAK STRENGTH **	EYE DIAMETER & LENGTH	MESH LENGTH	COLOR
033-02-044	.25" - .49"	6,800 lbs.	1/4" x 9"	26"	Dark Green
033-02-046	.50" - .74"	10,000 lbs.	5/16" x 9"	32"	Brown
033-02-048	.75" - .99"	14,400 lbs.	3/8" x 11"	41"	Light Blue
033-02-050	1.00" - 1.24"	24,600 lbs.	1/2" x 12"	52"	Gold
033-02-052	1.25" - 1.49"	30,600 lbs.	1/2" x 12"	56"	Black
033-02-054	1.50" - 1.74"	30,600 lbs.	1/2" x 12"	60"	Red
033-02-056	1.75" - 2.24"	48,000 lbs.	5/8" x 18"	70"	Dark Blue
033-02-1078	2.00" - 2.49"	48,000 lbs.	5/8" x 18"	50"	Yellow
033-02-1079	2.50" - 2.99"	48,000 lbs.	5/8" x 18"	52"	Orange
033-02-1080	3.00" - 3.49"	48,000 lbs.	5/8" x 18"	54"	Aluminum
033-02-1081	3.50" - 3.99"	48,000 lbs.	5/8" x 18"	58"	Light Green

** The maximum recommended load is 20% of the approximate breaking strength based on a 5:1 safety factor.



MULTIPLE STRENGTH GRIPS - ROTATING EYE

PART #	CABLE DIAMETER RANGE	APPROXIMATE BREAK STRENGTH **	EYE DIAMETER & LENGTH	MESH LENGTH	COLOR
033-02-016	.25" - .49"	6,800 lbs.	7/8" x 5"	26"	Dark Green
033-02-018	.50" - .74"	10,000 lbs.	1" x 6"	32"	Brown
033-02-020	.75" - .99"	14,400 lbs.	1" x 6"	41"	Light Blue
033-02-022	1.00" - 1.24"	24,600 lbs.	1-3/8" x 8"	52"	Gold
033-02-024	1.25" - 1.49"	30,600 lbs.	1-5/8" x 8"	56"	Black
033-02-026	1.50" - 1.74"	30,600 lbs.	1-7/8" x 9"	60"	Red
033-02-028	1.75" - 2.24"	48,000 lbs.	1-7/8" x 10"	70"	Dark Blue
033-02-066	2.00" - 2.49"	48,000 lbs.	1-7/8" x 10"	50"	Yellow
033-02-097	2.50" - 2.99"	48,000 lbs.	1-7/8" x 10"	52"	Orange
033-02-1030	3.00" - 3.49"	48,000 lbs.	1-7/8" x 10"	54"	Aluminum
033-02-1031	3.50" - 3.99"	48,000 lbs.	1-7/8" x 10"	58"	Light Green

** The maximum recommended load is 20% of the approximate breaking strength based on a 5:1 safety factor.

WIRE MESH PULLING GRIPS

Designed for overhead transmission line stringing applications, these are the highest strength grips available. They have the dual function of working with both bare and insulated conductors and synthetic rope.



DUA-PULL GRIPS - FLEXIBLE EYE

* For rope, select the smallest size grip which meets the required working load.

** The maximum recommended load is 20% of the approximate breaking strength based on a 5:1 safety factor.

PART #	CABLE DIAMETER RANGE	ROPE DIAMETER RANGE *	APPROXIMATE BREAK STRENGTH **	EYE DIAMETER & LENGTH	MESH LENGTH	COLOR
033-27-1037	.19" - .37"	.25" - .65"	6,500 lbs.	.22" x 10"	24"	Black
033-27-1038	.38" - .62"	.50" - .90"	14,000 lbs.	.375" x 12"	36"	Dark Green
033-27-1039	.63" - .87"	.75" - 1.10"	20,000 lbs.	.437" x 13"	48"	Red
033-27-1040	.88" - 1.12"	1.00" - 1.50"	30,600 lbs.	.500" x 15"	60"	Dark Blue
033-27-1041	1.13" - 1.37"	1.25" - 1.70"	46,800 lbs.	.625" x 18"	76"	Yellow
033-27-1042	1.38" - 1.90"	1.50" - 2.10"	66,500 lbs.	.750" x 24"	89"	Aluminum

** The maximum recommended load is 20% of the approximate breaking strength based on a 5:1 safety factor.

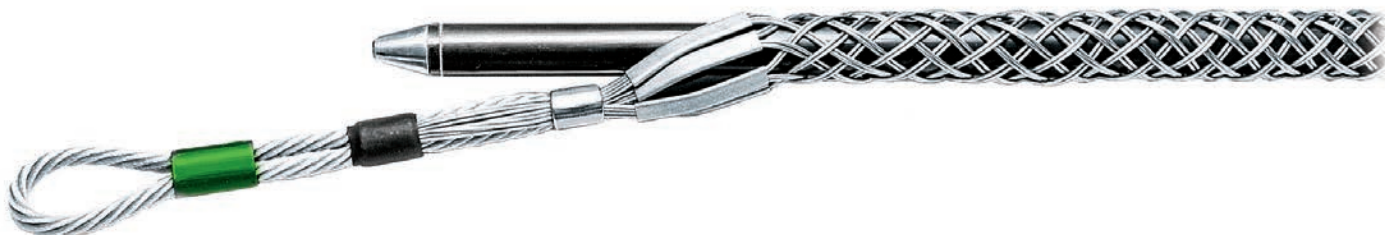

DUA-PULL FEED TUBES

Full lines of support grips and strain relief grips are available as well as grips for low tension pulling and fiber optics.

PART #	ROPE DIAMETER	LENGTH	FOR USE WITH GRIP #
091-06-1043	.25" - .65"	28"	033-27-1037
091-06-1044	.50" - .90"	40"	033-27-1038
091-06-1045	.75" - 1.10"	52"	033-27-1039
091-06-1046	1.00" - 1.50"	67"	033-27-1040
091-06-1047	1.25" - 1.70"	83"	033-27-1041
091-06-1048	1.50" - 2.10"	96"	033-27-1042

** The maximum recommended load is 20% of the approximate breaking strength based on a 5:1 safety factor.

LINE SWIVELS

Line swivels are not designed to run around bull wheels. Severe damage or injury may occur.

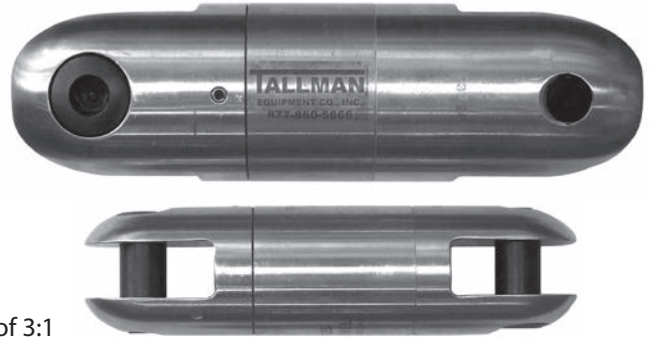
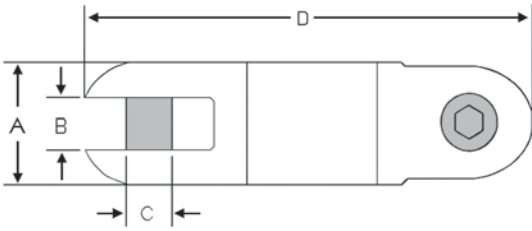

* Safety Factor of 3:1

LINE SWIVEL

Constructed with a thrust bearing for tensile load and a radial bearing for bending load.

All sizes incorporate an oil seal and are made of stainless steel.

PART #	SAFE WORKING LOAD *	A	B	C	D	HEX KEY SIZE	SLOTTED PART #
00505-010	2,250 lbs.	7/8"	3/8"	5/16"	3-3/8"	7/32"	00010-SLT
00505-020	5,000 lbs.	1-1/4"	17/32"	13/32"	4-3/4"	1/4"	00020-SLT
00505-025	7,000 lbs.	1-3/8"	9/16"	1/2"	5-1/8"	5/16"	00025-HEX
00505-030	10,000 lbs.	1-5/8"	11/16"	5/8"	6"	3/8"	00030-HEX
00505-035	15,000 lbs.	2"	25/32"	11/16"	7"	3/8"	00035-HEX
00505-040	25,000 lbs.	2-3/8"	1-1/32"	7/8"	10-5/16"	3/8"	00045-HEX

* Safety Factor of 3:1

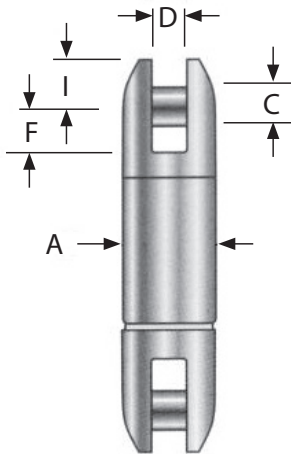

LINE SWIVEL

Heat treated high strength alloy steel (zinc plated for corrosion resistance), provides the strongest yet lightest swivel available.

PART #	SAFE WORKING LOAD *	A	C	D	F	I	LENGTH
6712	2,300 lbs.	7/8"	5/16"	5/16"	15/32"	3/8"	3-1/16"
6725	5,000 lbs.	1-1/4"	3/8"	19/32"	11/16"	7/16"	4-1/2"
6737	8,000 lbs.	1-1/2"	7/16"	19/32"	13/16"	9/16"	5-15/32"
6750	11,500 lbs.	1-7/8"	5/8"	3/4"	15/16"	13/16"	7-1/8"
6762	18,500 lbs.	2-7/16"	7/8"	1"	1-9/16"	1-1/8"	10-1/2"
6775	31,500 lbs.	2-7/8"	1"	1-9/32"	2-1/8"	1-1/4"	12-7/16"

* Safety factor of 3:1

LINE SWIVELS & CONNECTORS



NON-ROTATING CONNECTORS

Commonly used to connect mesh grips to the pulling wire.

The 2 smaller sizes have slotted pins while the larger sizes have hexagon pins. Other swivels and connectors are available.

PART #	3:1 SAFE WORKING LOAD	MAXIMUM ROPE DIAMETER	LENGTH	OPENING
00520-010	2,500 lbs.	7/8"	2-1/8"	3/8"
00520-020	5,000 lbs.	1-1/4"	2-7/8"	17/32"
00520-027	9,000 lbs.	1-1/2"	3-3/8"	19/32"
00520-035	15,000 lbs.	2"	4-9/16"	25/32"

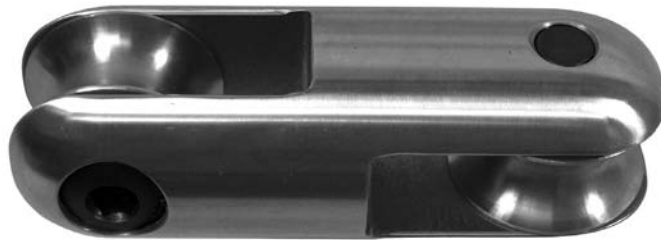

ROPE TO ROPE CONNECTOR

This product is used to connect two ropes of up to 7/8" diameter.

The entire product, including sheave, is manufactured from stainless steel. Other swivels and connectors are available.

PART #	3:1 SAFE WORKING LOAD	MAXIMUM ROPE DIAMETER	LENGTH
00521-035	15,000 lbs.	7/8"	5-1/2"



ROPE TO SWIVEL CONNECTORS

Used to connect pulling rope to above swivels. Both models have a maximum rope capacity of 7/8".

PART #	3:1 SAFE WORKING LOAD	MAXIMUM ROPE DIAMETER	LENGTH	TONGUE
00522-025	7,000 lbs.	2"	5-5/16"	1/2"
00522-035	15,000 lbs.	2"	5-3/8"	21/32"

BREAK-AWAY SWIVELS

Break-Away swivels are essential when pulling fiber optic and coaxial cable and are designed to separate at +10% of their rated load. If the load is exceeded, the internal pin breaks, the swivel separates and the cable remains undamaged.

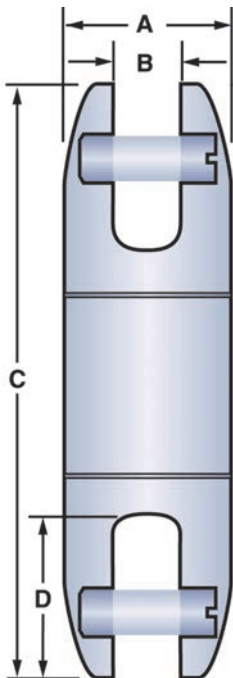

A	B	C	D
5/8" Break away swivel	.28"	3.56"	.79"
7/8" Break away swivel	.38"	4.51"	1.06"

5/8" SWIVELS

SWIVEL PART #	BREAK LOAD	REPLACEMENT PIN PART #
08017300	200 lbs.	08017305
08017400	250 lbs.	08017405
08017800	300 lbs.	08017805
08016900	450 lbs.	08016905
08017200	600 lbs.	08017205
08017500	650 lbs.	08017505
08017900	750 lbs.	08017905

7/8" SWIVELS

SWIVEL PART #	BREAK LOAD	REPLACEMENT PIN PART #
08018100	150 lbs.	08018105
08018300	200 lbs.	08018305
08018000	250 lbs.	08018005
08017600	300 lbs.	08017605
08018400	350 lbs.	08018405
08075300	400 lbs.	08075305
08015800	450 lbs.	08015805
08076500	500 lbs.	08076505
08018500	550 lbs.	08018505
08015000	600 lbs.	08015005
08018600	650 lbs.	08018605
08076000	700 lbs.	08076005
08075500	750 lbs.	08075505
08018700	800 lbs.	08018705
08018800	850 lbs.	08018805
08076600	900 lbs.	08076605
08015700	1,000 lbs.	08015705
08018900	1,100 lbs.	08018905
08015200	1,200 lbs.	08015205
08019100	1,300 lbs.	08019105
08074600	1,400 lbs.	08074605
08076900	1,500 lbs.	08076905
08019200	1,600 lbs.	08019205
08019300	1,700 lbs.	08019305
08017700	1,800 lbs.	08017705

CLAMPS & BANDING



BANDING TOOL

Band punching tool for 5/8" punch type clamps.

PART #
P-1000



CLAMP ADAPTER

Fits under pusher nose of P-1000 tool to apply 3/8" bands.

PART #
D-229



CLAMP-MASTER TOOL SET

Tool set for applying 3/8" and 5/8" punch type clamps.

PART #
P-38



BANDING TOOL

Tensioning tool for steel banding and buckle application.

PART #
PB-001



STANDARD-DUTY BUCKLES

PART #	WIDTH	BUCKLES PER CARTON
PB-253	3/8"	100
PB-254	1/2"	100
PB-255	5/8"	100
PB-256	3/4"	100



STANDARD-DUTY STEEL BANDING

PART #	BAND WIDTH	BAND THICKNESS
PB-203	3/8"	.025"
PB-204	1/2"	.030"
PB-205	5/8"	.030"
PB-206	3/4"	.030"



PRE-FORMED GALVANIZED PUNCH TYPE CLAMPS

PART #	INSIDE DIAMETER	BAND WIDTH	CLAMPS PER CARTON
P-3	13/16"	3/8"	100
P-4	1"	5/8"	100
P-6	1-1/2"	5/8"	100
P-8	2"	5/8"	100
P-10	2-1/2"	5/8"	50



OPEN-END GALVANIZED PUNCH TYPE CLAMPS

PART #	INSIDE DIAMETER	BAND WIDTH	CLAMPS PER CARTON
PO-3	13/16"	3/8"	100
PO-311	1-3/8"	3/8"	100
PO-8	2"	5/8"	100
PO-10	2-1/2"	5/8"	50
PO-12	3"	5/8"	50

Many other styles and sizes are available.

ROPE

Standard lengths 600' to 1,200'. Other sizes available.



POLYPROPYLENE ROPE

A general purpose rope made of monofilament polypropylene fiber. Lightweight and buoyant, it has good abrasion and UV resistance.

PART #	DIAMETER	MBS
TEPP-06	3/8"	2,440 lbs.
TEPP-08	1/2"	3,780 lbs.
TEPP-10	5/8"	5,600 lbs.
TEPP-12	3/4"	7,650 lbs.



DIELECTRIC 8-STRAND ROPE

The highest dielectric-strength rope available. A special treatment helps the rope retain its dielectric properties even when it becomes wet. Easily spliced.

CAUTION: ABSORBED MOISTURE WILL INCREASE CONDUCTIVITY.

PART #	DIAMETER	MBS
TEDR-06	3/8"	2,880 lbs.
TEDR-08	1/2"	5,040 lbs.
TEDR-09	9/16"	5,670 lbs.
TEDR-10	5/8"	7,020 lbs.



SSR-100-3

A combination fiber 3-strand rope with an excellent wear life and a high strength-to-weight ratio. This rope offers the durability of polyester, but with higher strengths. Excellent for hand lines and rigging lines.

PART #	DIAMETER	MBS
SNHP-04	1/4"	1,600 lbs.
SNHP-06	3/8"	3,700 lbs.
SNHP-08	1/2"	6,200 lbs.
SNHP-10	5/8"	9,000 lbs.



SSR-1200-3

A compound plied rope construction that utilizes the compatibility of filament polyester and Ultra Blue fibers. This combination yields strength and wear resistance equal to an all-polyester rope but with a significant reduction in weight.

PART #	DIAMETER	MBS
SNHP-12	3/4"	13,300 lbs.
SNHP-14	7/8"	18,800 lbs.
SNHP-16	1"	22,900 lbs.
SNHP-18	1 1/8"	29,500 lbs.



PRO-MASTER

This 3-strand rope is firm and balanced with superior hand and lock-grip holding capability. The combination of spun and filament polyester creates a rope with low stretch and excellent knot holding. The construction's firmness eliminates the hockling tendency of standard lay 3-strand ropes.

PART #	DIAMETER	MBS
SNPM-06	3/8"	2,900 lbs.
SNPM-08	1/2"	5,100 lbs.
SNPM-10	5/8"	6,900 lbs.
SNPM-12	3/4"	9,000 lbs.
SNPM-14	7/8"	13,100 lbs.



PRO-SET-3

A premium 3-strand, 4-stage nylon rope. It is manufactured to minimize shrinkage, snagging, and hockling, and maximize strength, durability, and flexibility. Pro-Set-3 is easy to handle and splice.

PART #	DIAMETER	MBS
SNPS-06	3/8"	3,200 lbs.
SNPS-08	1/2"	5,700 lbs.
SNPS-10	5/8"	9,000 lbs.
SNPS-12	3/4"	12,200 lbs.
SNPS-14	7/8"	17,100 lbs.

ROPE

Standard lengths 600' to 1,200'. Other sizes available.



TENEX

Tenex is a 12-strand single braid that offers high strength with low stretch and outstanding abrasion resistance. It is Samthane coated to provide abrasion resistance, enhance wear life, snag resistance, and increase ease of splicing.

PART #	DIAMETER	MBS
SNTN-04	1/4"	2,900 lbs.
SNTN-06	3/8"	5,200 lbs.
SNTN-08	1/2"	10,600 lbs.
SNTN-10	5/8"	15,400 lbs.
SNTN-12	3/4"	20,200 lbs.
SNTN-14	7/8"	29,300 lbs.



TENEX-TEC

High-strength, low-stretch rope specifically designed with two ends per carrier. This construction allows more rope surface conformance to objects being lifted than standard single braid constructions. Samthane coated to enhance its wear life.

PART #	DIAMETER	MBS
SNTNT-06	3/8"	5,500 lbs.
SNTNT-08	1/2"	11,800 lbs.
SNTNT-10	5/8"	16,900 lbs.
SNTNT-12	3/4"	22,300 lbs.
SNTNT-14	7/8"	30,800 lbs.
SNTNT-16	1"	40,100 lbs.



AMSTEEL

A strong, lightweight high-performance rope, made with Dyneema[®] and Innegra[™] fiber, samthane coated, highly flex-fatigue resistant, highly abrasion resistant, non rotational, wire rope replacement.

PART #	DIAMETER	MBS
SNAS-04	1/4"	6,700 lbs.
SNAS-05	5/16"	9,500 lbs.
SNAS-06	3/8"	14,000 lbs.
SNAS-07	7/16"	16,200 lbs.
SNAS-08	1/2"	24,800 lbs.
SNAS-09	9/16"	30,600 lbs.
SNAS-10	5/8"	36,600 lbs.
SNAS-12	3/4"	46,800 lbs.
SNAS-13	13/16"	54,900 lbs.
SNAS-14	7/8"	66,600 lbs.
SNAS-16	1"	81,000 lbs.



AMSTEEL[®]-BLUE

AmSteel[®]-Blue is a torque-free, 12-strand single braid that yields the maximum in strength-to-weight ratio and, size-for-size, is the same strength as steel—yet it floats. AmSteel[®]Blue is an excellent wire rope replacement with extremely low stretch, and superior flex fatigue and wear resistance.

PART #	DIAMETER	MBS
SNASB-04	1/4"	7,700 lbs.
SNASB-05	5/16"	12,300 lbs.
SNASB-06	3/8"	17,600 lbs.
SNASB-07	7/16"	21,500 lbs.
SNASB-08	1/2"	30,600 lbs.
SNASB-09	9/16"	36,500 lbs.
SNASB-10	5/8"	47,500 lbs.
SNASB-12	3/4"	58,000 lbs.
SNASB-13	13/16"	73,800 lbs.
SNASB-14	7/8"	81,700 lbs.
SNASB-16	1"	98,100 lbs.

ROPE

Standard lengths 600' to 1,200'. Other sizes available.



DURA-PLEX

In Dura-Plex, a 12-strand single braid, the composite strands are braided together using parallax construction to produce a rope with an excellent strength-to-weight ratio.

PART #	DIAMETER	MBS
SNDP-04	1/4"	1,600 lbs.
SNDP-06	3/8"	3,500 lbs.
SNDP-08	1/2"	6,000 lbs.
SNDP-10	5/8"	10,400 lbs.
SNDP-12	3/4"	13,100 lbs.
SNDP-14	7/8"	19,100 lbs.
SNDP-16	1"	22,500 lbs.



STABLE BRAID

A firm, polyester, double braided rope with high strength, low stretch, and excellent resistance to wear. Durable torque free construction.

PART #	DIAMETER	MBS
SNSB-06	3/8"	4,800 lbs.
SNSB-08	1/2"	8,800 lbs.
SNSB-10	5/8"	13,900 lbs.
SNSB-12	3/4"	17,300 lbs.
SNSB-14	7/8"	25,400 lbs.
SNSB-16	1"	33,300 lbs.
SNSB-18	1-1/8"	41,000 lbs.
SNSB-20	1-1/4"	48,700 lbs.
SNSB-24	1-1/2"	63,800 lbs.



AMSTEEL® II

AmSteel® II has a strong core with a cover that creates a firm rope while serving to protect the strength-member core. This rope has extremely low elongation and is a lightweight replacement for wire rope. Coating enhances abrasion resistance and provides color options.

PART #	DIAMETER	MBS
SNAS2-04	1/4"	3,800 lbs.
SNAS2-06	3/8"	8,300 lbs.
SNAS2-08	1/2"	13,200 lbs.
SNAS2-10	5/8"	23,000 lbs.
SNAS2-12	3/4"	29,800 lbs.
SNAS2-14	7/8"	42,500 lbs.
SNAS2-16	1"	48,500 lbs.
SNAS2-18	1-1/8"	62,000 lbs.
SNAS2-20	1-1/4"	68,900 lbs.



AMSTEEL® II PLUS

A high-strength core with a cover that creates a firm rope while serving to protect the strength-member core. This rope has extremely low elongation and is a lightweight replacement for wire rope. Coating enhances abrasion resistance and provides color options.

PART #	DIAMETER	MBS
SNAS2P-04	1/4"	4,800 lbs.
SNAS2P-06	3/8"	10,400 lbs.
SNAS2P-08	1/2"	16,500 lbs.
SNAS2P-10	5/8"	28,700 lbs.
SNAS2P-12	3/4"	37,200 lbs.
SNAS2P-14	7/8"	53,100 lbs.
SNAS2P-16	1"	60,600 lbs.
SNAS2P-18	1-1/8"	76,500 lbs.
SNAS2P-20	1-1/4"	85,900 lbs.

STRINGING LINE

Pulling and stringing lines are available in custom lengths to any size. Samson stringing rope offers low stretch and durability along with abrasion resistance. Call Tallman Equipment for the full range of sizes and additional specifications.



Steel reels are sold separately.

SAMSON STRINGING ROPE

Tenex rope is a 12-strand single braid that offers high strength with low stretch and outstanding abrasion resistance. It is Samthane coated to provide abrasion resistance, enhance wear life, snag resistance, and increase ease of splicing.

PART #	DIAMETER	LENGTH	COLORS	MBS
SNTN05	5/16"	Custom lengths to any size	See color chart	4,200 lbs.
SNTN06	3/8"	Custom lengths to any size	See color chart	5,200 lbs.
SNTN07	7/16"	Custom lengths to any size	See color chart	8,100 lbs.
SNTN10	5/8"	Custom lengths to any size	See color chart	15,400 lbs.

When ordering stringing line rope, follow this procedure from the charts below.
Part number + length + color (Example: SNTN07-8500-GRN)



© Samson Rope Technologies

COLOR CHART

Tenex stringing rope is available in the following colors. Refer to the abbreviations to include in your part number.

WHITE	=	WHT
YELLOW	=	YEL
BLACK	=	BLK
GOLD	=	GLD
RED	=	RED
GREEN	=	GRN
ORANGE	=	ORG
GRAY	=	GRA
BLUE	=	BLU

WINCH LINE

Our in house samson certified splicers will manufacture each winch line to your exact specifications.
Chafe gear, nylite assemblies and thimbles available upon request.



AMSTEEL® BLUE

A 12-strand single braid that yields the maximum in strength-to-weight ratio and, size-for-size, is the same strength as steel. Amsteel® Blue is an excellent wire rope replacement with extremely low stretch, and superior flex fatigue and wear resistance. WLL ratio based on Samson Rope Minimum Breaking Strength.

PART #	DIMENSIONS	EYES	WLL (5:1 RATIO)
WLAB08EE4-200	1/2" x 200'	4" Soft	6,120 lbs.
WLAB08EE3-300	1/2" x 300'	3" Soft	6,120 lbs.
WLAB10EE3-250	5/8" x 250'	3" Soft	9,500 lbs.
WLAB12EE4-200	3/4" x 200'	4" Soft	11,600 lbs.
WLAB14EE4-90	7/8" x 90'	4" Soft	16,340 lbs.
WLAB14EE4-100	7/8" x 100'	4" Soft	16,340 lbs.
WLAB16EE4-130	1" x 130'	4" Soft	19,620 lbs.
WLAB16EE4-140	1" x 140'	4" Soft	19,620 lbs.



STABLE BRAID

A firm, polyester, double braided rope with high strength, low stretch, and excellent resistance to wear.
WLL ratio based on Samson Rope Minimum Breaking Strength.

PART #	DIMENSIONS	EYES	WLL (5:1 RATIO)
WLSB07EE3-65	7/16" x 65'	3" Soft	1,300 lbs.
WLSB07EE4-65	7/16" x 65'	4" Soft	1,300 lbs.
WLSB07EE4-80	7/16" x 80'	4" Soft	1,300 lbs.
WLSB08EE4-60	1/2" x 60'	4" Soft	1,760 lbs.
WLSB08EE3-65	1/2" x 65'	3" Soft	1,760 lbs.
WLSB08EE3-80	1/2" x 80'	3" Soft	1,760 lbs.
WLSB08EE4-80	1/2" x 80'	4" Soft	1,760 lbs.
WLSB08EE4-100	1/2" x 100'	4" Soft	1,760 lbs.
WLSB14EE4-70	7/8" x 70'	4" Soft	5,080 lbs.
WLSB14EE4-80	7/8" x 80'	4" Soft	5,080 lbs.
WLSB16EE3-60	1" x 60'	3" Soft	6,660 lbs.
WLSB16EE4-60	1" x 60'	4" Soft	6,660 lbs.
WLSB16EE4-70	1" x 70'	4" Soft	6,660 lbs.
WLSB16EE4-85	1" x 85'	4" Soft	6,660 lbs.
WLSB16EE3-100	1" x 100'	3" Soft	6,660 lbs.
WLSB16EE4-100	1" x 100'	4" Soft	6,660 lbs.
WLSB16EE3-115	1" x 115'	3" Soft	6,660 lbs.
WLSB16EE4-115	1" x 115'	4" Soft	6,660 lbs.
WLSB16EE3-125	1" x 125'	3" Soft	6,660 lbs.
WLSB16EE4-125	1" x 125'	4" Soft	6,660 lbs.
WLSB18EE4-100	1-1/8" x 100'	4" Soft	8,200 lbs.

WINCH LINE

Our in house samson certified splicers will manufacture each winch line to your exact specifications.
Chafe gear, nylite assemblies and thimbles available upon request.

AMSTEEL® II

The core that consists of a Dyneema® and Innegra™-S fiber blend and has a braided polyester cover. This creates a firm rope while serving to protect the strength-member core. This rope has extremely low elongation and is a lightweight replacement for wire rope. WLL ratio based on Samson Rope Minimum Breaking Strength.

PART #	DIMENSIONS	EYES	WLL (5:1 RATIO)
WLA207EE4-105	7/16" x 105'	4" Soft	1,980 lbs.
WLA208EE4-75	1/2" x 75'	4" Soft	2,640 lbs.
WLA214EE4-80	7/8" x 80'	4" Soft	8,500 lbs.
WLA214EE4-90	7/8" x 90'	4" Soft	8,500 lbs.
WLA214EE4-115	7/8" x 115'	4" Soft	8,500 lbs.
WLA216EE4-80	1" x 80'	4" Soft	9,700 lbs.
WLA216EE4-90	1" x 90'	4" Soft	9,700 lbs.
WLA216EE4-115	1" x 115'	4" Soft	9,700 lbs.
WLA216EE4-120	1" x 120'	4" Soft	9,700 lbs.
WLA216EE4-130	1" x 130'	4" Soft	9,700 lbs.
WLA218EE4-115	1-1/8" x 115'	4" Soft	12,400 lbs.
WLA218EE4-120	1-1/8" x 120'	4" Soft	12,400 lbs.
WLA218EE4-130	1-1/8" x 130'	4" Soft	12,400 lbs.
WLA218EE4-140	1-1/8" x 140'	4" Soft	12,400 lbs.



AMSTEEL® II PLUS

Made with a 100% Dyneema® fiber core and a braided polyester cover.
This is a strong, high performance rope that is lightweight, has low elongation and can replace wire rope.
WLL ratio based on Samson Rope Minimum Breaking Strength.

PART #	DIMENSIONS	EYES	WLL (5:1 RATIO)
WLA2P07EE4-105	7/16" x 105'	4" Soft	2,480 lbs.
WLA2P08EE4-75	1/2" x 75'	4" Soft	3,300 lbs.
WLA2P14EE4-80	7/8" x 80'	4" Soft	10,620 lbs.
WLA2P14EE4-90	7/8" x 90'	4" Soft	10,620 lbs.
WLA2P14EE4-115	7/8" x 115'	4" Soft	10,620 lbs.
WLA2P16EE4-80	1" x 80'	4" Soft	12,120 lbs.
WLA2P16EE4-90	1" x 90'	4" Soft	12,120 lbs.
WLA2P16EE4-115	1" x 115'	4" Soft	12,120 lbs.
WLA2P16EE4-120	1" x 120'	4" Soft	12,120 lbs.
WLA2P16EE4-130	1" x 130'	4" Soft	12,120 lbs.
WLA2P18EE4-115	1 1/8" x 115'	4" Soft	15,300 lbs.
WLA2P18EE4-120	1 1/8" x 120'	4" Soft	15,300 lbs.
WLA2P18EE4-130	1-1/8" x 130'	4" Soft	15,300 lbs.
WLA2P18EE4-140	1-1/8" x 140'	4" Soft	15,300 lbs.



ROPE ACCESSORIES

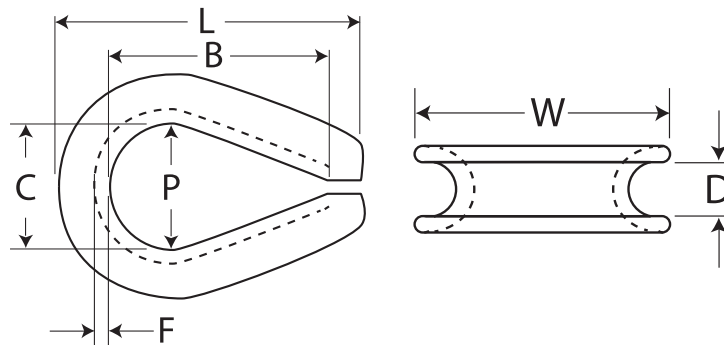

HOT ROLLED MILD GALVANIZED THIMBLE

PART #	ROPE DIAMETER	B	C	D	F	L	P	W
SNMLT-04	1/4"	1-5/8"	7/8"	9/32"	1/16"	2-1/8"	13/16"	1-1/2"
SNMLT-06	3/8"	2-1/8"	1-1/8"	7/16"	7/64"	3"	1-1/16"	2-1/8"
SNMLT-08	1/2"	2-3/4"	1-1/2"	5/8"	9/64"	3-5/8"	1-7/16"	2-11/16"
SNMLT-10	5/8"	3-1/4"	1-3/4"	11/16"	5/32"	4-1/4"	1-5/8"	3-1/8"
SNMLT-12	3/4"	3-3/4"	2"	13/16"	7/32"	5"	1-7/8"	3-13/16"
SNMLT-16	1"	4-1/2"	2-1/2"	1-1/16"	1/4"	6-1/8"	2-3/8"	4-15/16"
SNMLT-18	1-1/8"	5-1/8"	2-7/8"	1-5/16"	1/4"	7"	2-3/4"	5-7/8"

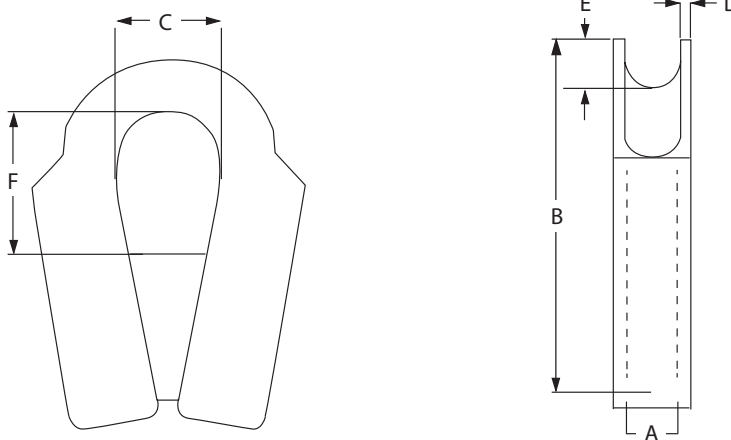

BLUE LINE THIMBLE

The Blue Line Thimble is compatible with Samson's high-performance, high-modulus synthetic fiber rope products such as AmSteel® Blue, Force 8, and DPX™ 75. The tubular gusseted design creates a high-strength thimble that protects the rope and maintains the proper bending radius when connected to mating hardware.

PART #	ROPE DIAMETER	THIMBLE WEIGHT	A	B	C	D	E	F
SNBLT-06	3/16" - 3/8"	.80 lbs.	.50"	3.3"	.90"	.20"	.30"	.90"
SNBLT-08	7/16" - 1/2"	1.1 lbs.	.60"	3.7"	1.1"	.20"	.40"	1.2"
SNBLT-10	9/16" - 5/8"	1.4 lbs.	.80"	4.4"	1.3"	.20"	.50"	1.8"
SNBLT-14	3/4" - 7/8"	2.0 lbs.	.90"	4.9"	1.4"	.20"	.60"	1.9"
SNBLT-18	1" - 1-1/8"	5.8 lbs.	1.4"	7.5"	2.4"	.30"	.90"	2.9"
SNBLT-24	1-1/4" - 1-1/2"	7.5 lbs.	1.8"	9.0"	2.8"	.30"	1.1"	3.7"
SNBLT-28	1-5/8" - 1-11/16"	10.3 lbs.	2.0"	10.0"	3.0"	.30"	1.2"	3.8"
SNBLT-32	1-3/4" - 2"	10.8 lbs.	2.2"	10.6"	3.2"	.30"	1.4"	3.9"

ROPE ACCESSORIES



SMALL ALUMINUM FID KIT

Designed for splicing, climbing, or rigging lines. Kit includes five aluminum tubular fids, 1/4" through 1/2" and small pusher.

PART #
SNSK



LARGE ALUMINUM FID KIT

Large fid kit ideal for mechanics working on pullers, diggers, winch lines and more. Contains 6 aluminum tubular fids, 1/2" - 9/16" - 5/8" - 3/4" - 7/8" - 1" in an easy-to-store kit.

PART #
9990075

NYLON WEBBING CHAFE PROTECTORS

Chafe protectors are woven product that is produced in a tubular format. Made of 100% industrial nylon with twice the abrasion resistance of normal nylon and three times the abrasion resistance of polyester. This product is commonly added to the eyes of working lines and can be installed on the rope as well. Available in any length.

PART #	ROPE DIAMETER	COLOR
MW11344P0138-P	1-3/8"	Yellow
MW12159N0200YELR	2"	Yellow
MW12159N0200ORNR	2"	Orange
MW12159N0300YELR	3"	Yellow
MW12159N0300ORNR	3"	Orange
MW12159N0300BLUER	3"	Blue
MW12159N0400YELR	4"	Yellow
MW12159N0400BLUER	4"	Blue



DDIN MESH BAG

PART #	SIZE
DNMB-1019	10" x 19"



CONDUCTOR STRINGING SYSTEM



AT-75C



AT-75-SR

PILOT LINE CONTROLLER

This Pilot Line System consists of a positive braking controller and a storage reel of rope, which mount on the lead pole at any desired height. This unique system saves labor and eliminates dangling "finger lines".

PART #	DESCRIPTION
AT-75CRR	AT-75 Pilot line controller, reel with rope
AT-75C	S-75 Controller for 3000 ft. Reel and rope
AT-75-SR	AT-75 Storage reel for 3000 ft. of rope
AT-75 3000 ROPE	3000 ft. - 5/16 braided rope
AT-75WA	AT-75 Adapter, winch shaft with spring
AT85 CRR	Pilot Controller, reel with rope
AT85 C	Controller for 6000 ft. reel and rope
AT85 SR	Fabricated steel reel for 6000 ft. of rope
AT85 Rope	6000 ft. of 5/16 braided rope

CONDUCTOR STRINGING SYSTEM

A lightweight and compact hydraulic pulling system that is ideal for the installation of distribution conductors. Can also be used as a pilot rope pulling system. This system can be powered from the hydraulic circuit of a line truck or by a portable hydraulic power unit.



PULLER UNIT

Pulls 1,000 lbs. at 400 fpm with a supply of 15 GPM at 2,000 PSI. Features an Anti-Roll Back Pin to prevent backlash. Supplied with 2 ratchet straps and 2 hoses with quick disconnect couplers.

PART #	WEIGHT
811863	215 lbs.



PULLING ROPE

12-strand polyester, this 3/8" diameter rope is supplied in 3,000' lengths. Order rope and storage reels separately. Weight of reel & rope is 119 lbs.

PART #	COLOR
TN06-3000-GRN	Green
TN06-3000-BLU	Blue
TN06-3000-ORG	Orange
TN06-3000-YEL	Yellow
811491	Steel Reel



Payout spindles are also available with nylon straps.

PAYOUT SPINDLE

This unit has an adjustable disc brake that can be operated with a hotstick. It is mounted to the pole with a chain binder. Made of galvanized steel.

PART #	WEIGHT
8000816	35 lbs.

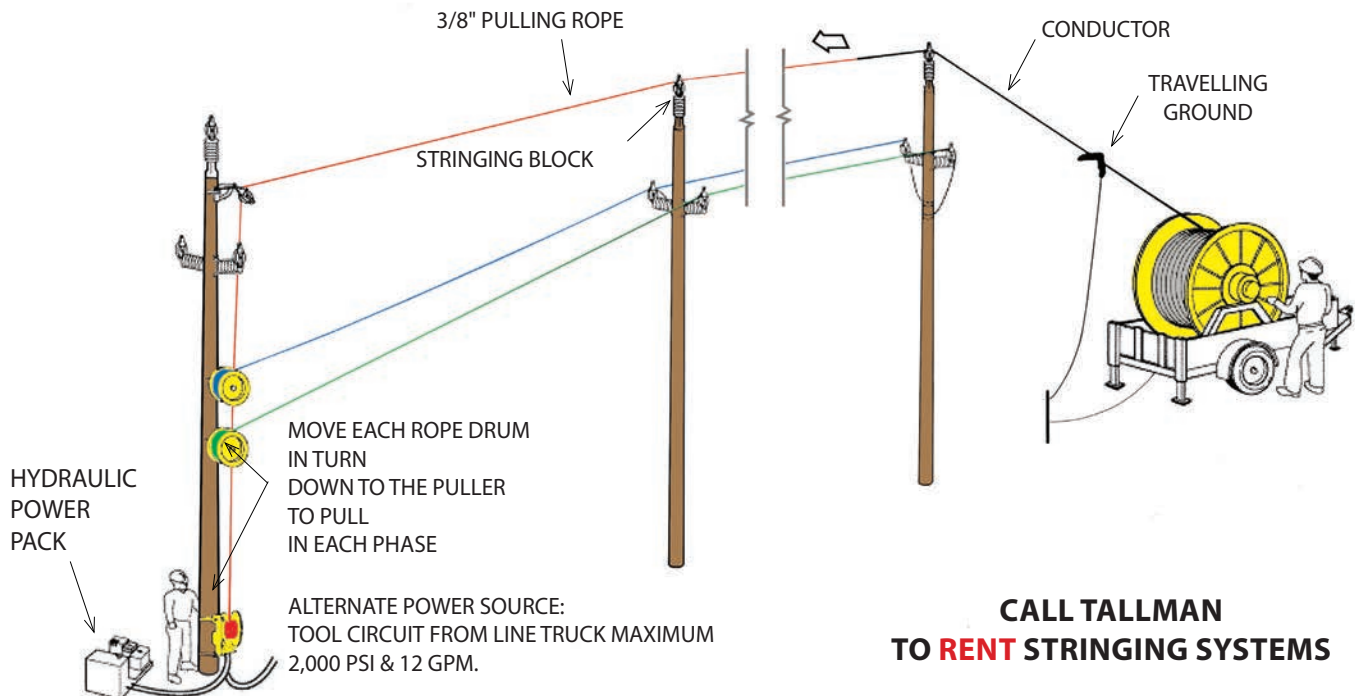

**CALL TALLMAN
TO RENT STRINGING SYSTEMS**

STEEL WIRE BASKETS

Collapsible and stackable steel wire baskets for shipping or storage.



S-7 STEEL WIRE BASKET

Standard storage uses:
 (200) Cross arm brackets (100) 7" Stringing blocks
 (20) 16" Stringing blocks (10) 22" Stringing blocks

PART #	DIMENSIONS	WEIGHT (EMPTY)
DNS-7	47" x 40" x 36"	130 lbs.



S-10 STEEL WIRE BASKET

Standard storage uses:
 (25) 5' Extension arm (10) 28" Stringing blocks

PART #	DIMENSIONS	WEIGHT (EMPTY)
DNS-10	67" x 44" x 41"	178 lbs.



S-11 STEEL WIRE BASKET

Standard storage uses:
 (25) 6' Extension arms

PART #	DIMENSIONS	WEIGHT (EMPTY)
DNS-11	79" x 43" x 36"	215 lbs.



S-12 STEEL WIRE BASKET

Standard storage uses:
 (3) 42" Stringing blocks

PART #	DIMENSIONS	WEIGHT (EMPTY)
DNS-12	61" x 39" x 49"	168 lbs.

BULK SHIPPING CONTAINERS

Other sizes and options available.



BN48453420



BN48454420



BS70483422

BULK SHIPPING CONTAINERS

These shipping containers collapse flat in seconds and stack for storage and return shipment. Hand-hold areas on the panels provide a comfortable grip for assembling and collapsing the containers. Lids available.

PART #	CAPACITY	DIMENSIONS	WEIGHT	COLOR	LID PART#
BN48453420	2,500 lbs.	48" x 45" x 34"	122 lbs.	Blue or Black	TS48450300
BN48454420	2,000 lbs.	48" x 45" x 44"	154 lbs.	Black	TS48450300
BS70483422	2,000 lbs.	70" x 48" x 34"	195 lbs.	Black	TV70480200

UNIVERSAL STRINGING BLOCKS

A high-strength alloy frame gives these blocks a 2,500 lb. safe working load. The throat opening is 3-3/4" high and 3-1/8" wide. The 3" wide by 7" diameter sheaves run on heavy duty sealed ball bearings. The blocks can be mounted to a crossarm, an insulator bracket, or suspended. Blocks with aluminum sheaves weigh 8.5 lbs. Blocks with ductile iron sheaves weigh 15.5 lbs.

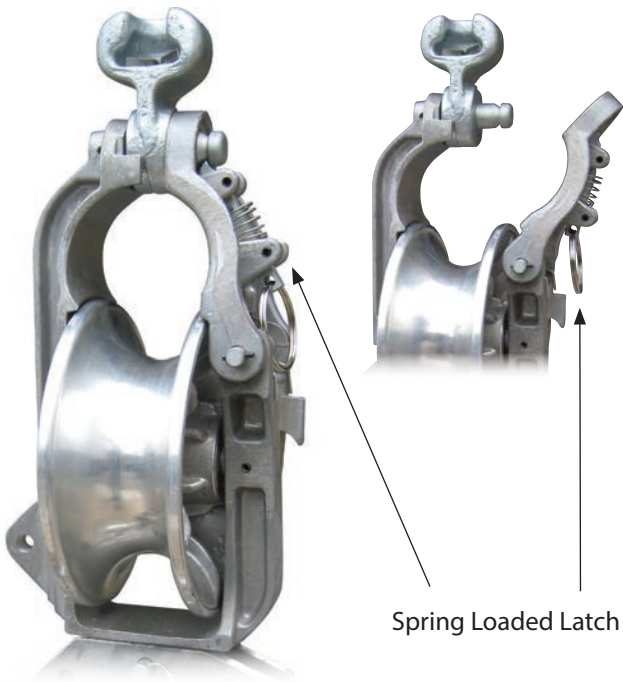

Spring Loaded Latch

CB1 STRINGING BLOCK

The spring loaded latch on the gate can be operated with a hot stick. The gate is held open by placing the ring on to the holding hook. When the ring is released, the heavy duty spring positively locks the gate closed. Safe working load of 2,500 lbs.

PART #	SHEAVE
DNCB-1AL	Aluminum
DNCB-1DI	Ductile Iron
DNCB-1LS	Urethane Lined

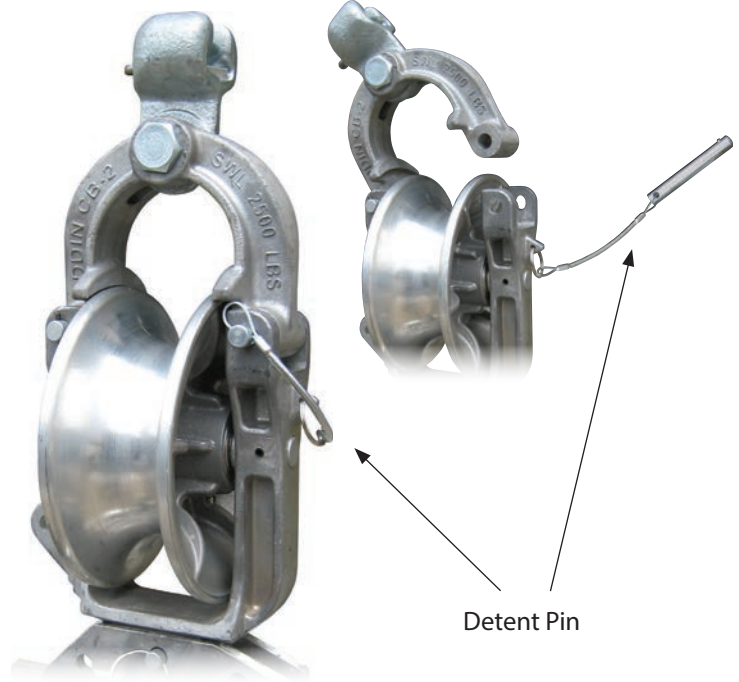

Detent Pin

CB2 STRINGING BLOCK

The CB-2 has the same capacities as the CB-1 but the head is kept closed with a ball detent pin. When opened, the head drops to the side fully exposing the top of the sheave. Safe working load of 2,500 lbs.

PART #	SHEAVE
DNCB-2AL	Aluminum
DNCB-2DI	Ductile Iron
DNCB2-2LS	Urethane Lined

See page 230 for universal mounting brackets and attachments. See page 403 - 404 for DNCB-1 & DNCB-2 repair parts.

SHEAVES

All 7" universal blocks are available with the following sheaves. Specify when ordering.



ALUMINUM (AL)



DUCTILE IRON (DI)



URETHANE LINED (LS)

UNIVERSAL STRINGING BLOCKS



UPLIFT STRINGING BLOCK

Used for uplift conditions, a hold down rope can be attached to the block frame. The side gate locks closed with a spring plunger. It can be suspended or attached to a mounting bracket. The maximum wire diameter is 1-3/4".

PART #	WLL	SHEAVE
DNCB-77	2,500 lbs.	Aluminum
DNCB-77LS	2,500 lbs.	Urethane Lined

See page 230 for universal mounting brackets and attachments.

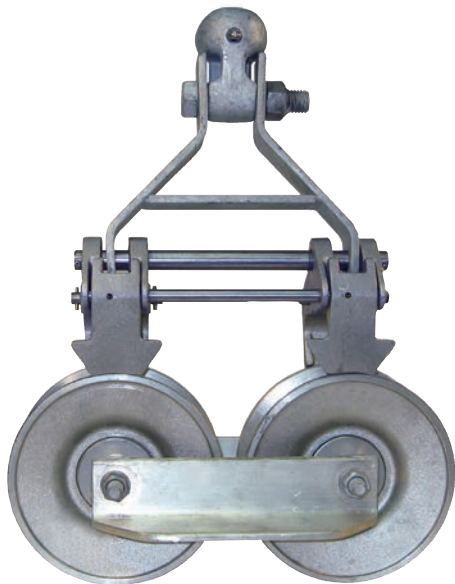

DOUBLE ROLLER STRINGING BLOCK

This block pivots 90° to facilitate stringing applications where the conductor is usually dead-ended or around a sharp corner. Safe working load is 2,000 lbs.

PART #
R-10963

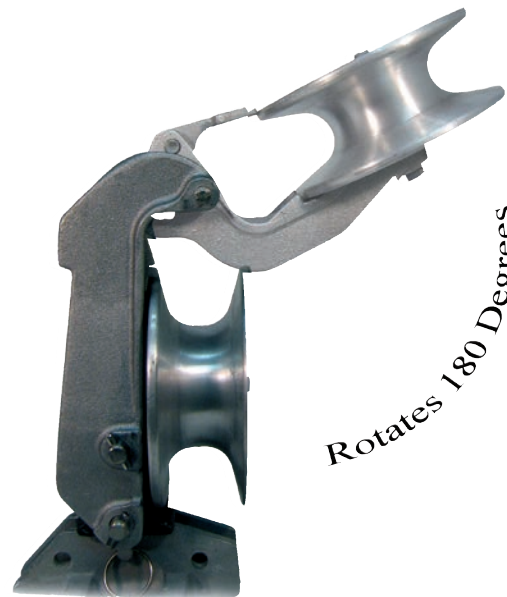

Rotates 180 Degrees

ALL ANGLE STRINGING BLOCK

This block can be suspended or attached to a universal crossarm bracket (see page 230). With the socket eye removed, the 6-1/2" sheave easily rotates a full 180°.

PART #
5903-S

MOUNTING BRACKETS & ATTACHMENTS

TALLMAN RENTS BLOCKS, BRACKETS & ATTACHMENTS.



SAFETY HOOK

2,000 lb. safe working load.
Use only with 7" blocks.



BALL CLEVIS



BALL CLEVIS

with captive pin.



Y-BALL CLEVIS

PART #
T12

PART #
14

PART #
14A

PART #
15



S823

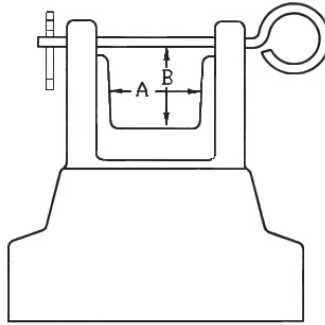

S823-SR

PIN TOP STRINGING BLOCKS

Used for installing distribution class wire below 35kV. Made of a patented polymer, these blocks fit standard NEMA pins with 1" ACME threads. Replaceable steel rollers and plastic inserts.

PART #	DESCRIPTION	A	B
S823	Block with plastic insert	1.75"	2.50"
S823-SI	Block with steel insert	2.50"	2.90"
S823-SR	Block with steel roller	2.87"	1.87"



UNIVERSAL CROSSARM BRACKET

Fits crossarms up to 4-1/2" x 5-1/2".
See page 401 for DNAB-1 repair parts.



UNIVERSAL CROSSARM BRACKET

Fits crossarms up to 4-1/2" x 5-1/2" with positive locking detent pin. See page 402 for DNAB-2 repair parts.



UNIVERSAL CROSSARM BRACKET

Fits crossarms up to 6-1/4" x 7".



INSULATOR BRACKET

For mounting blocks to tie-top post insulators. The rubber covered brackets firmly grip and adjust to different size insulators.

PART #
DNAB-1

PART #
DNAB-2

PART #
DNAB-6

PART #
DNIB-1

SPECIALTY BLOCKS

Radius blocks are used instead of full diameter blocks. Lightweight and durable, they rotate freely from a vertical to horizontal position when used on a corner structure.

5 ROLLER, 24" RADIUS BLOCK

5" diameter sheaves available in aluminum, urethane, ductile iron. 19" H x 40" L with captive top rollers. Accepts wire up to 3" diameter.

PART #	SHEAVE	WLL	WEIGHT
DNRB5324-AL	Aluminum	4,000 lbs.	72 lbs.
DNRB5324-DI	Ductile Iron	4,000 lbs.	88 lbs.
DNRB5324-LS	Urethane Lined	4,000 lbs.	74 lbs.

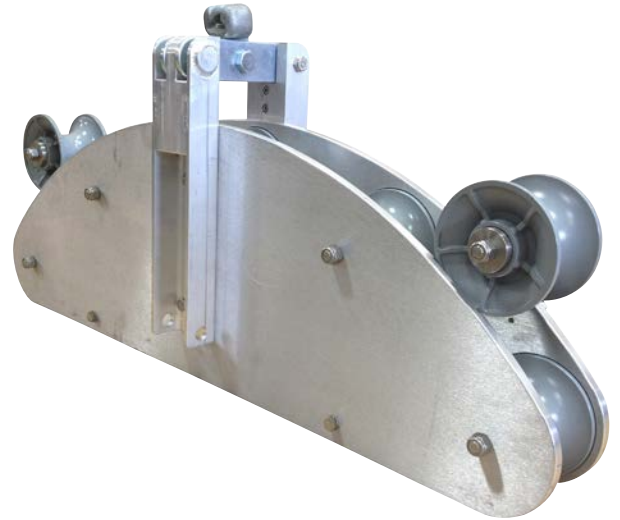

DNRB5324-DI

3 ROLLER, 22" RADIUS BLOCK WITH 7" SHEAVES

7" diameter sheaves available in aluminum, urethane, ductile iron. 16" H x 23-1/2" L. Accepts wire up to 2" diameter.

PART #	SHEAVE	WLL	WEIGHT
DNRB3222-AL	Aluminum	4,000 lbs.	30 lbs.
DNRB3222-DI	Ductile Iron	4,000 lbs.	43 lbs.
DNRB3222-LS	Urethane Lined	4,000 lbs.	32 lbs.

See page 405 for DNRB3222 repair parts.



DNRB3222-AL

UPLIFT/HOLD-DOWN BLOCK

Designed to hold the pulling line or conductor down when they tend to float or rise up out of the stringing block groove. Can also be used to lower conductor for inspection or other work. The 7" lined rollers are in tandem to help reduce bending of the conductor.

Accepts wire up to 1-3/4" capacity.

PART #	WLL (5:1 RATIO)	WEIGHT
DNUL-7L	3,500 lbs.	26 lbs.

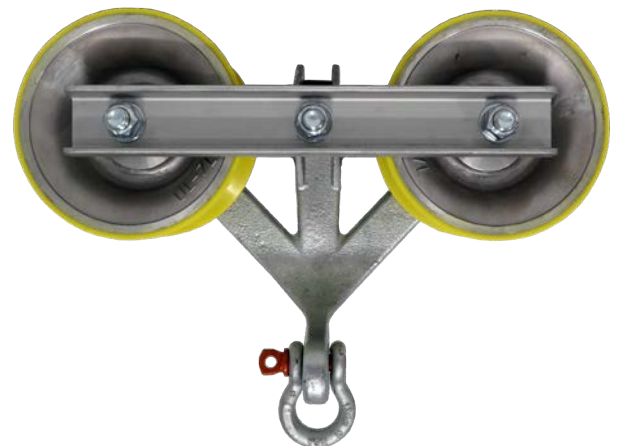

STRINGING BLOCKS

All of our Transmission Stringing Blocks are constructed of an all aluminum alloy making them lightweight yet strong and durable. The urethane lined sheaves prevent damage to the conductor and run smoothly on anti-friction bearings packed in a synthetic grease that is impervious to extreme temperatures. These blocks feature an added lifting bar in the center of the frame and another bar at the bottom to tie the block off at an angle. The socket eye accepts the ball clevises on page 230.

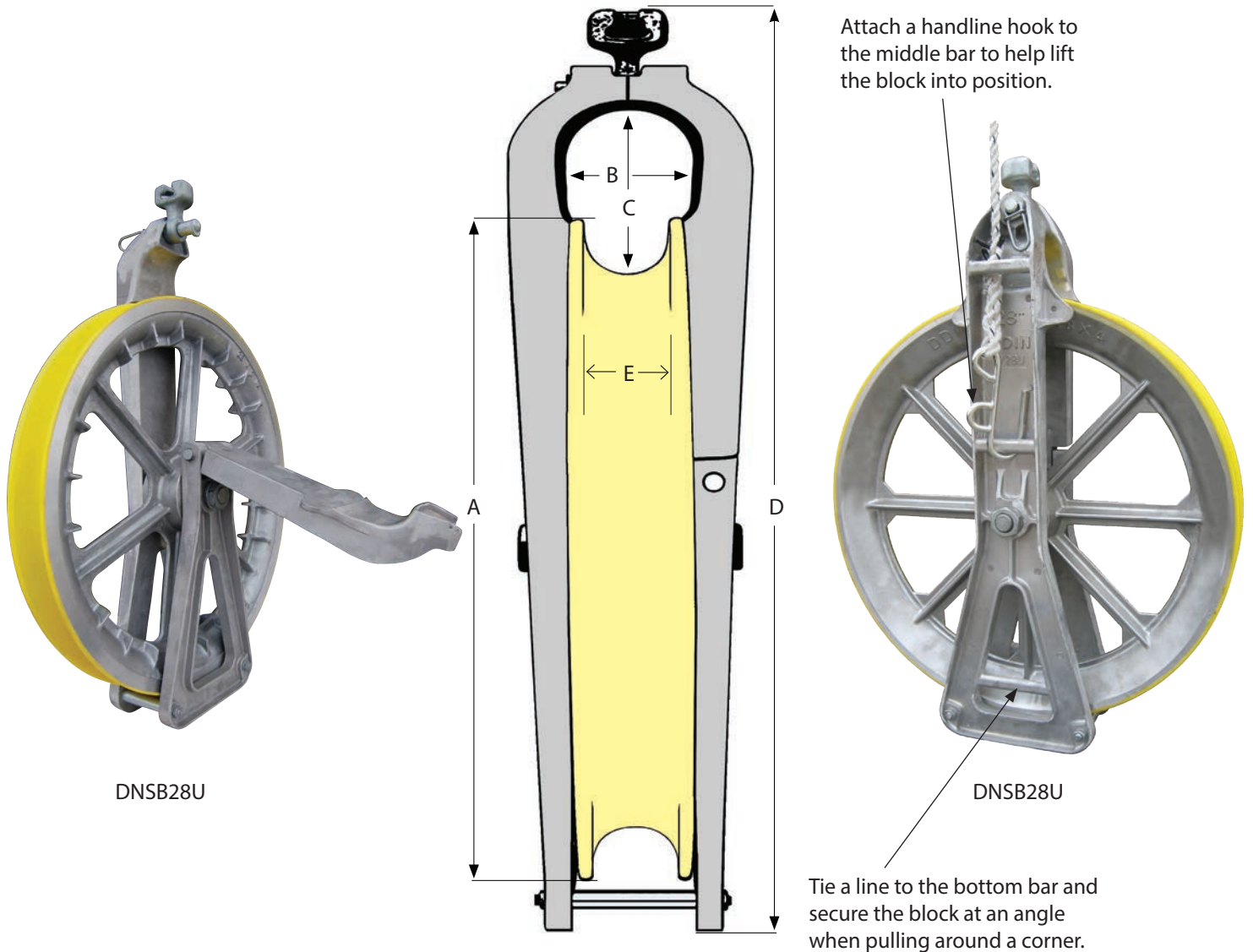

STRINGING BLOCKS

The four sizes of large throat blocks allows you to choose the right size block for the job. Their large throat openings allow for passage of most sleeves and connectors.

PART #	A	B	C	D	E	WLL	WEIGHT
DNSB12U	12"	2-1/2"	4"	21-7/8"	1-3/8"	12,000 lbs.	20 lbs.
DNSB16U	16"	2-1/2"	5-1/4"	26-1/2"	1-3/8"	12,000 lbs.	30 lbs.
DNSB22U	22"	3-1/8"	5-5/8"	31-9/16"	2"	12,000 lbs.	52 lbs.
DNSB28U	28"	3-1/4"	5-11/16"	38-3/4"	2-3/8"	12,000 lbs.	62 lbs.

See page 406 - 408 for DNSB16U, DNSB22U, and DNSB28U repair parts.

STRINGING BLOCKS

TALLMAN CAN **RE-LINE** YOUR USED STRINGING BLOCKS.

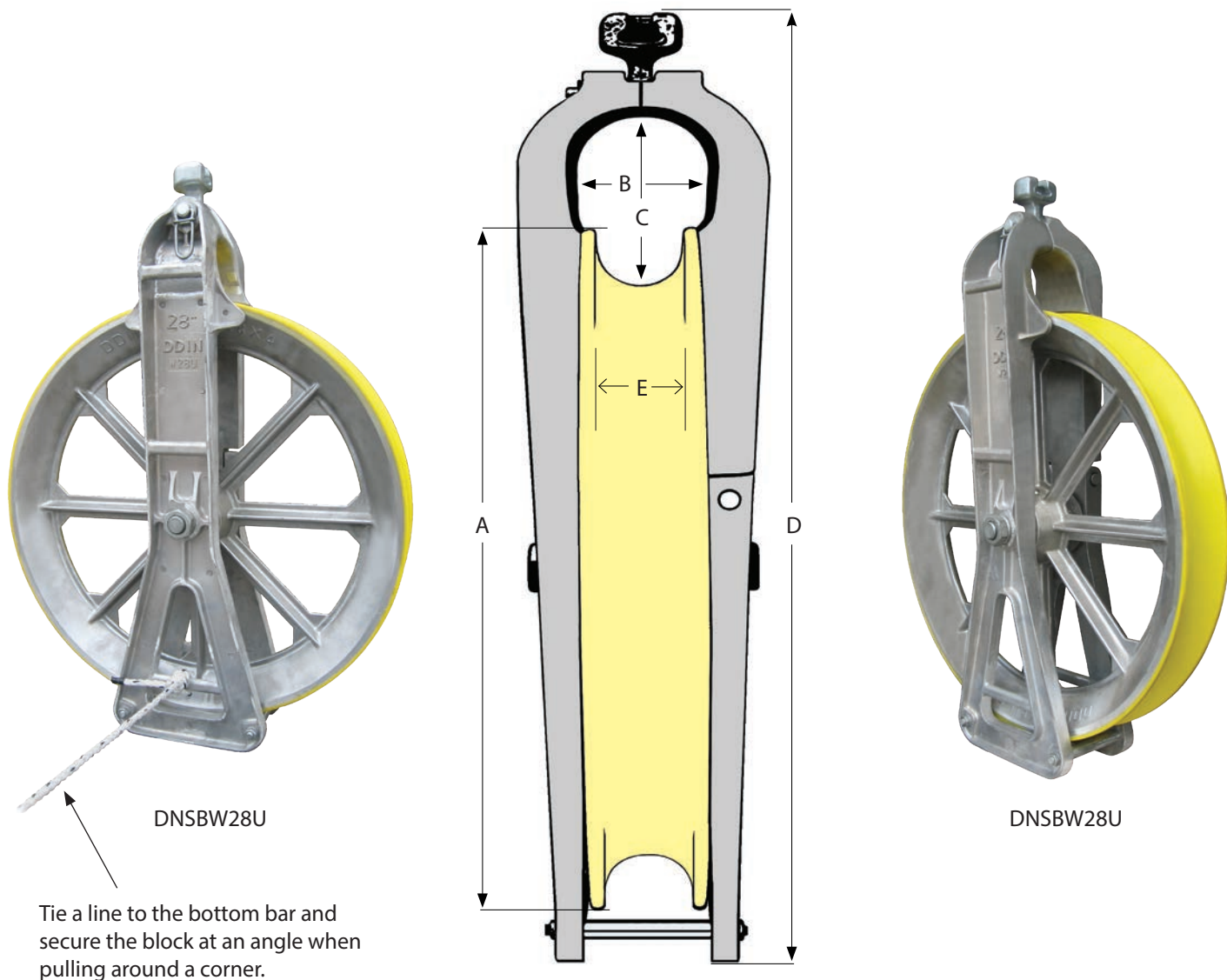

Tie a line to the bottom bar and secure the block at an angle when pulling around a corner.

WIDE THROAT STRINGING BLOCKS

These are a larger version of our standard stringing blocks.

The deep "V-Groove" wide sheave is designed to improve the installation of T2 & VR2 conductors.

PART #	A	B	C	D	E	WLL	WEIGHT
DNSBW16U	16"	4"	5-3/4"	26-3/4"	3.25"	12,000 lbs.	40 lbs.
DNSBW22U	22"	4"	5-1/2"	32-1/2"	3"	12,000 lbs.	62 lbs.
DNSBW28U	28"	4"	5-1/2"	38-3/4"	3.25"	12,000 lbs.	70 lbs.
DNSBW36U	36"	5"	6-1/2"	47-1/4"	3-5/8"	12,000 lbs.	144 lbs.
DNSBW42U	42"	5-3/8"	6-3/8"	53"	4"	12,000 lbs.	170 lbs.

See page 409 - 411 for DNSBW16U, DNSBW22U, and DNSBW28U repair parts.

HELICOPTER STRINGING BLOCKS

HELICOPTER ARM

16" receiving arm is easily attached or removed with the locking detent pins. Pull detent pins to use block without arm.

PART #
DNHB-7ARM

UNIVERSAL HELICOPTER BLOCK

The 16" receiving arm is easily attached or removed with the locking detent pins.

A heavy duty spring keeps the gate closed after the conductor is dropped in.

Weights 15 lbs. with aluminum sheave and the arm attached.

PART #	SHEAVE	WLL
DNHB-7AL	Aluminum	2,500 lbs.
DNHB-7DI	Ductile Iron	2,500 lbs.
DNHB-7LS	Urethane Lined	2,500 lbs.

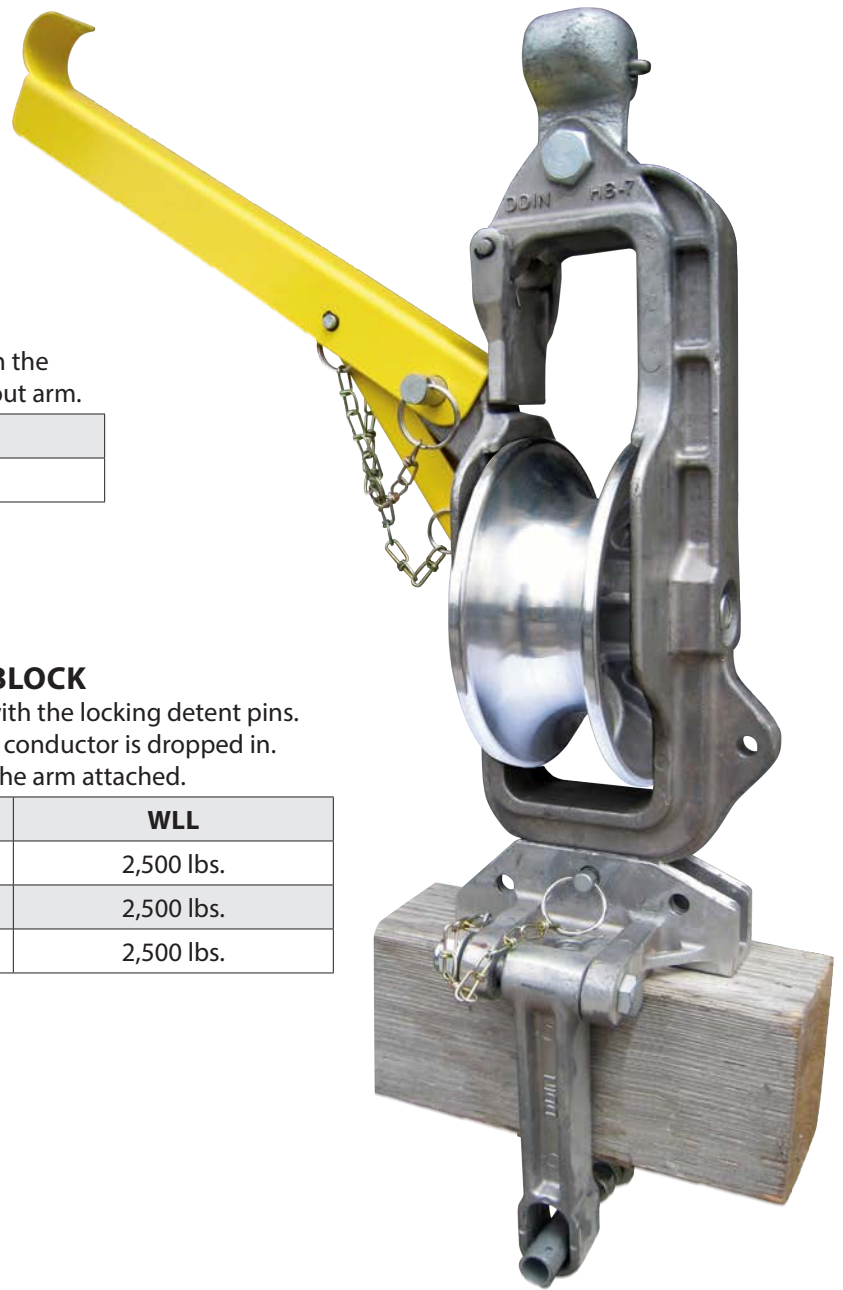

SHEAVES

All 7" universal helicopter blocks are available with the following sheaves. Specify desired sheave when ordering.



ALUMINUM (AL)



DUCTILE IRON (DI)



URETHANE LINED (LS)

HELICOPTER STRINGING BLOCKS

Ideal for stringing multiple sizes of single overhead conductors where the pilot line will be flown in. One of the unique features is the exclusive "Snap Lock" fold away Helicopter Arm, which eliminates the need for removing pins to deploy or retract the fly arm. Combined with a 12,000 lbs. working load, spring loaded side gate and synthetically lubricated shielded bearings these helicopter blocks ensure smooth and consistent operation in the toughest of environments.

Snap lock fold away helicopter arm, eliminates the need for removing pins to deploy or retract the fly arm.

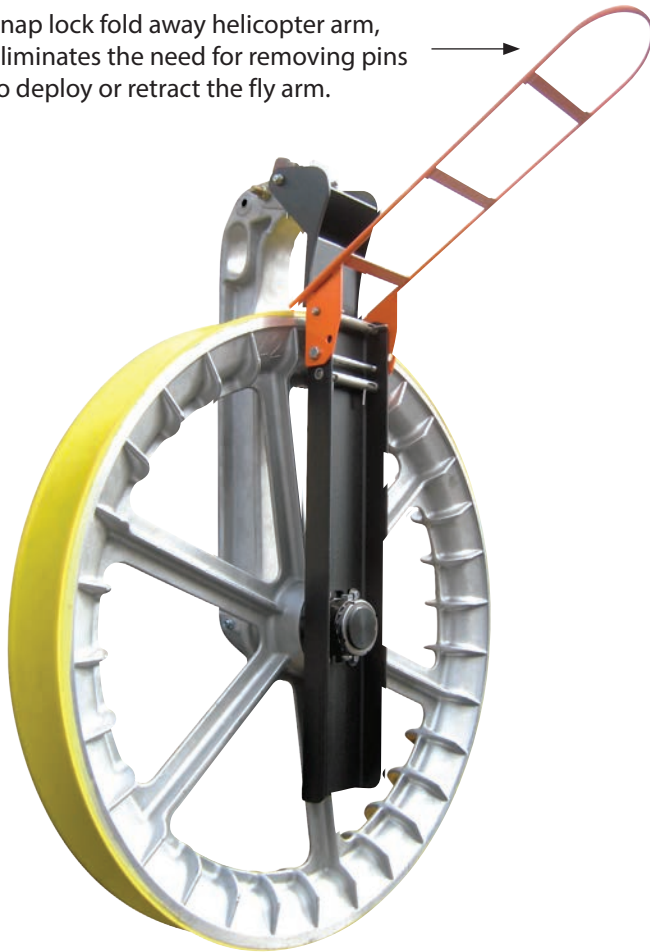

DNSBW42UH

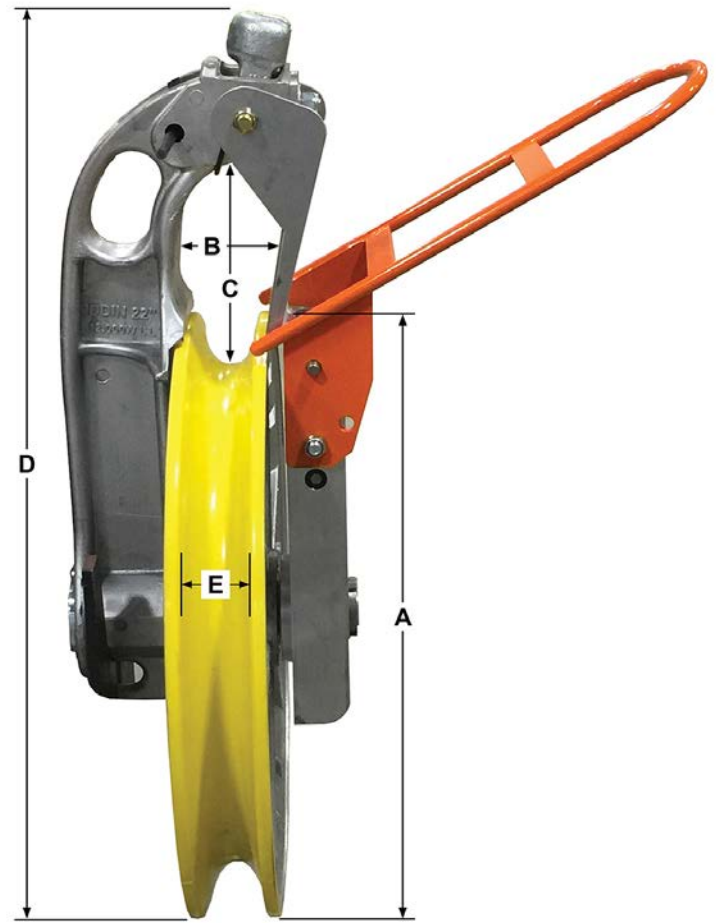

DIMENSION KEY

STANDARD HELICOPTER BLOCKS

PART #	A	B	C	D	E	WLL	WEIGHT
DNSB22UH	22"	3-3/8"	7-1/2"	32-1/2"	2"	12,000 lbs.	62 lbs.
DNSB28UH	28"	3-1/2"	7-1/2"	39"	2-3/8"	12,000 lbs.	74 lbs.

WIDE THROAT HELICOPTER BLOCKS

The "V-Groove" urethane lined sheave is designed to improve the installation of twisted pair conductors, referred to as T2® or VR2®.

PART #	A	B	C	D	E	WLL	WEIGHT
DNSBW22UH	22"	3-3/4"	7-1/2"	32-1/2"	3 1/4"	12,000 lbs.	72 lbs.
DNSBW28UH	28"	4"	7-1/2"	39"	3-1/4"	12,000 lbs.	78 lbs.
DNSBW36UH	36"	5-3/8"	10-1/2"	49-1/4"	4"	12,000 lbs.	165 lbs.
DNSBW42UH	42"	5-3/8"	10-3/4"	55"	4"	12,000 lbs.	190 lbs.

GROUNDED STRINGING BLOCKS

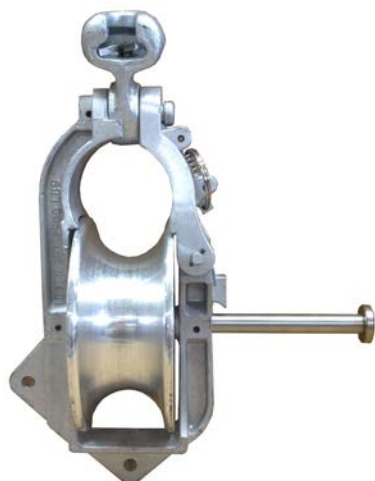

DNCB-1GAL

DNCB-1 STRINGING BLOCK WITH GROUND STUD

See page 228 for DNCB-1 stringing blocks.

PART #	SHEAVE
DNCB-1GAL	Aluminum
DNCB-1GDI	Ductile Iron
DNCB-2GAL	Aluminum

GROUNDED STRINGING BLOCKS

These are our grounded stringing blocks and wide throat stringing blocks with a unique grounding attachment mounted to the frame. The 3/4" x 4-1/2" stud accepts virtually any grounding clamp. The roller of the grounding attachment is kept in constant contact with the conductor by dual heavy-duty springs.

Use ball clevises on page 230.

PART #	A	B	C	D	WLL	WEIGHT
DNSB12UG	12"	2-1/2"	4"	21-7/8"	12,000 lbs.	30 lbs.
DNSB16UG	16"	2-1/2"	5-1/4"	26-1/2"	12,000 lbs.	35 lbs.
DNSB22UG	22"	3-1/8"	5-5/8"	31-9/16"	12,000 lbs.	64 lbs.
DNSB28UG	28"	3-1/4"	5-11/16"	38-3/4"	12,000 lbs.	75 lbs.

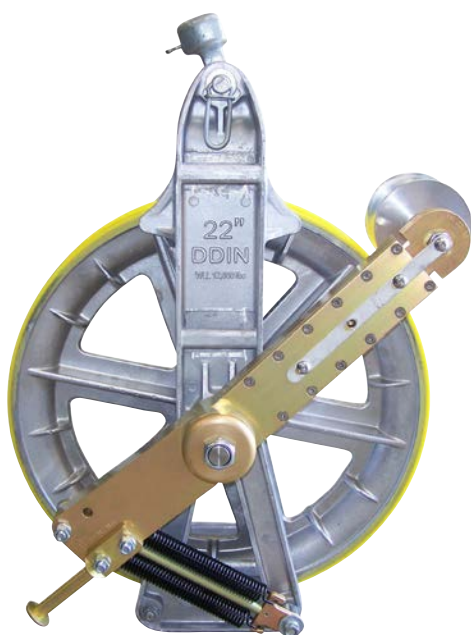

DNSB22UG

WIDE THROAT GROUNDED STRINGING BLOCKS

PART #	A	B	C	D	WLL	WEIGHT
DNSBW22UG	22"	4"	5-1/2"	32-1/2"	12,000 lbs.	86 lbs.
DNSBW28UG	28"	4"	5-1/2"	38-3/4"	12,000 lbs.	92 lbs.
DNSBW36UG	36"	5"	6-1/2"	47-1/4"	12,000 lbs.	224 lbs.
DNSBW42UG	42"	5-3/8"	6-3/8"	53"	12,000 lbs.	247 lbs.

GROUNDED ATTACHMENT

Grounded Attachments can be purchased separately and installed on DDIN 12", 16", 22", 28", 36" or 42" stringing blocks converting it to a grounded stringing block.

PART #	DESCRIPTION
DNBG12	For DNSB12U only
DNBG16	For DNSB16U only
DNBG22-28	For DNSB22U & DNSB28U only
DNBGV22-28	For DNSBW22U & DNSBW28U only
DNBGV36	Factory install for DNSBW36U only
DNBGV42	Factory install for DNSBW42U only



DNBG22-28

TRAVELING GROUNDS

An important component of every conductor stringing project, traveling grounds maintain a positive contact from conductor to ground through the use of a ground wire. All models have a reversible ground stud which accommodates almost any type of ground clamp. All models have adjustable spring loaded center roller to maintain the correct pressure on the conductor.



TRAVELING GROUND

Wire capacity of .250" to 1.625".

See page 413 - 414 for DNTG250-1625 repair parts.

RECOMMENDED FOR DISTRIBUTION APPLICATIONS

PART #	DESCRIPTION	WEIGHT
DNTG250-1625	Aluminum Rollers	4.75 lbs.
DNTG250-1625S	Steel Rollers	4.75 lbs.



TRAVELING GROUND

Wire capacity 3/4" to 2".

See page 412 for DNTG75-2HD repair parts.

PART #	DESCRIPTION	WEIGHT
DNTG75-2HD	Aluminum Rollers	10.5 lbs.
DNTG75-2HDS	Steel Rollers	10.5 lbs.

The DNTG550 and DNTG80 were designed and engineered specifically for T2 wire. The sheave radius allows the T2 wire to move through the traveling ground without causing damage or milking of the wire. The two bottom rollers on each model prevent the traveling ground from jumping off of the wire during the pull.

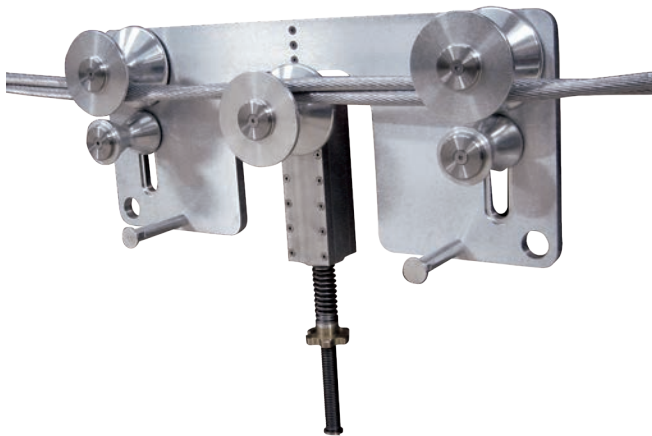

TRAVELING GROUND

Wire range of T2 4/0 through 556.

PART #	DESCRIPTION	WEIGHT
DNTG550	5-1/2" Aluminum Rollers	62 lbs.



TRAVELING GROUND

Wire range of T2 795 through 1113.

PART #	DESCRIPTION	WEIGHT
DNTG80	8" Aluminum Rollers	92 lbs.

TRAVELING GROUNDS & ACCESSORIES

Picture below shows the grounding assembly using GR43BS2 and DNG2B2M during a typical conductor installation.

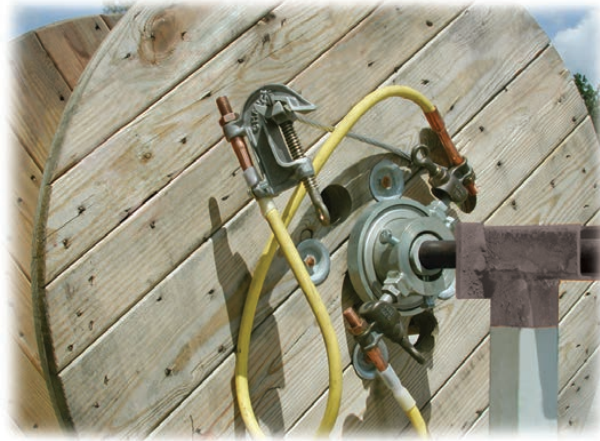

ROTATING GROUND ADAPTER

This unique tool provides protection while the conductor is pulled from reels. It adds conductor grounding but does not replace other grounding practices. The adapter slides on the reel mandrel. The outer collar connects to the tail of the conductor on the reel and the inner collar is connected to a ground rod.

PART #

GR43BS2

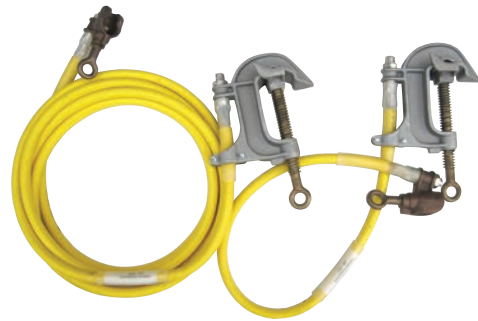

CABLE REEL GROUNDING SET

Consisting of a 3' length and a 15' length of 2/0 yellow jacketed cable, both with ball stud clamps on one end and C-type clamps on the other.

PART #

DNG2B2M

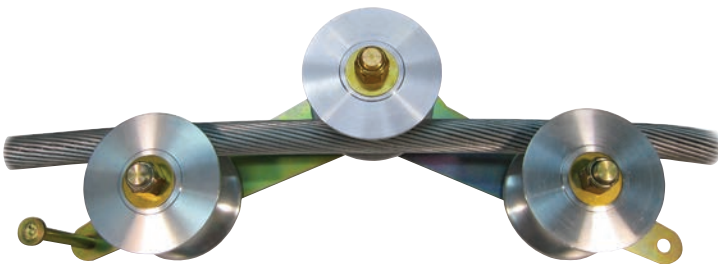

TRAVELING GROUND

Conductor capacity of 1.040"(795)MCM through 2-1/2". The torsion spring permits passage of splices and swivels. Comes standard with aluminum rollers but steel rollers are also available. Total weight is 18 lbs.

PART #

DN353

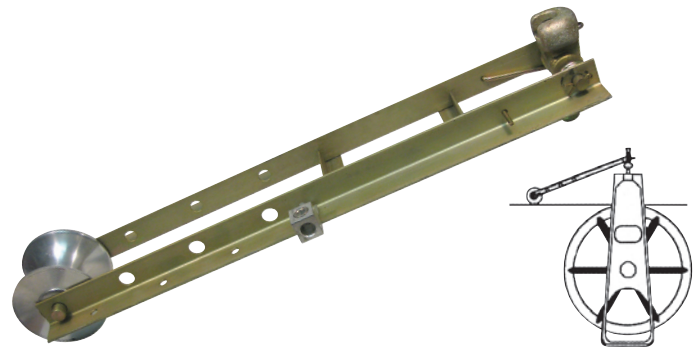

GROUND ATTACHMENT

Converts any standard 12" to 36" stringing block with a socket eye into a grounded stringing block. It accommodates all conductor sizes and is spring loaded to keep the roller in contact with the conductor. Mesh grips and swivels pass through the roller in either direction.

PART #

DN12-36

SAGGING EQUIPMENT



The S22-771 is load tested and serialized prior to shipment.

CLIPPING HOOK

6,500 lb safe working load. Each unit is tagged showing the safe working load, test date, and an identifying serial number.

PART #	DIMENSIONS	WEIGHT
S22-771	6-1/4" x 5-1/2" x 14-1/2"	7.8 lbs.

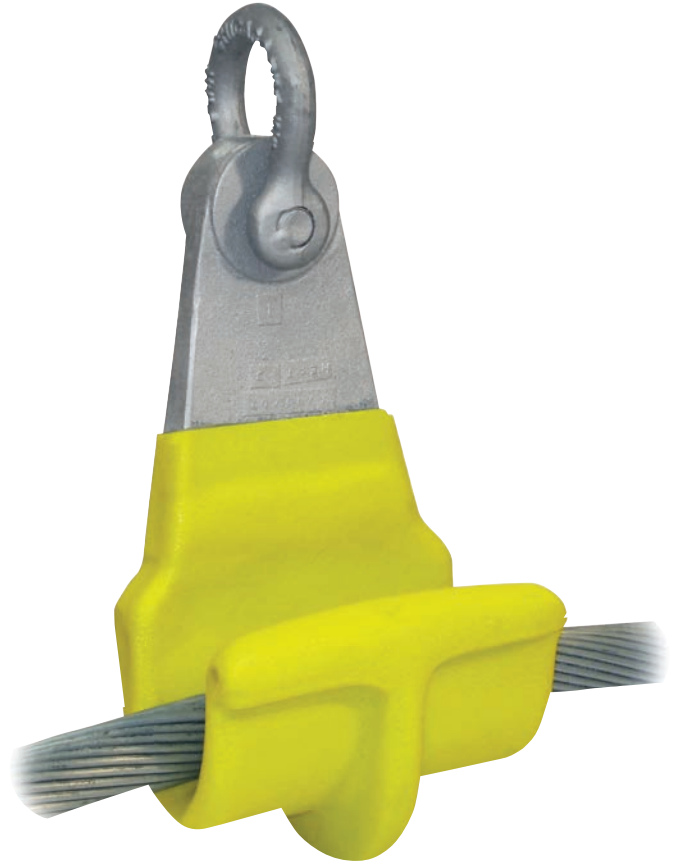

SAG SCOPE

The "Double Bubble" feature allows for vertical & horizontal leveling. The 3 x 9 power scope with cross hairs mounts easily to either wooden poles or steel structures. Kit includes a padded, high-impact storage case.

PART #
724

SAGGING EQUIPMENT



SAGWATCH

Used to accurately determine sag simply and rapidly. Water & shock resistant, it is antimagnetic and housed in a stainless steel case.

PART #		
SW-E		
SCALE	CAPACITY	GRADUATIONS
3rd return	Sag up to 36'	Feet & decimals
5th return	Sag up to 100'	Feet & decimals
Seconds	Seconds up to 30	Tenth of a second



SAGOMETER

A calibrated thermometer encased in a section of aluminum conductor. This helps determine the temperature of the conductor being sagged. It has a range from -40° to 160° F.

PART #
DNCT40-160



POCKET THERMOMETER

This thermometer has a range from -50° to 120° F.

PART #
21412-2J



ANALOG DYNAMOMETERS

Accurately displays weight in any direction within 0.5% of full scale. Dynamometers / load cell / load links are instruments that display the tension force exerted between two attached shackles. They are generally used to determine tension in a line or suspended weight.

5" DIALS	
PART #	CAPACITY & DIVISIONS
30006-0035	2,000 lbf x 20
30006-0050	5,000 lbf x 50
30006-0084	10,000 lbf x 100
30006-0100	20,000 lbf x 200
30784-0033	50,000 lbf x 200

10" DIALS	
PART #	CAPACITY & DIVISIONS
30007-0109	20,000 lbf x 100
30784-0017	30,000 lbf x 200

SAGGING EQUIPMENT

EDJUNIOR DYNAMOMETER

The EDjunior dynamometer gets straight to the point, apply a load - take a reading. LCD displays 1" high digits with 0.2% accuracy of capacity.

PART #	CAPACITY X RESOLUTION
EDJR-1T	2,500 lbf x 2
EDJR-2T	5,000 lbf x 5
EDJR-5T	10,000 lbf x 10
EDJR-10T	25,000 lbf x 20

Other models available, contact Tallman for more information.

EDXTREME DYNAMOMETER

The EDxtreme exemplifies the trademark precision and rugged construction of Dillon dynamometers. 1" high digits with 0.2% accuracy of capacity.

PART #	CAPACITY X RESOLUTION
EDX-1T	2,500 lbf x 2
EDX-2T	5,000 lbf x 5
EDX-5T	10,000 lbf x 10
EDX-10T	25,000 lbf x 20

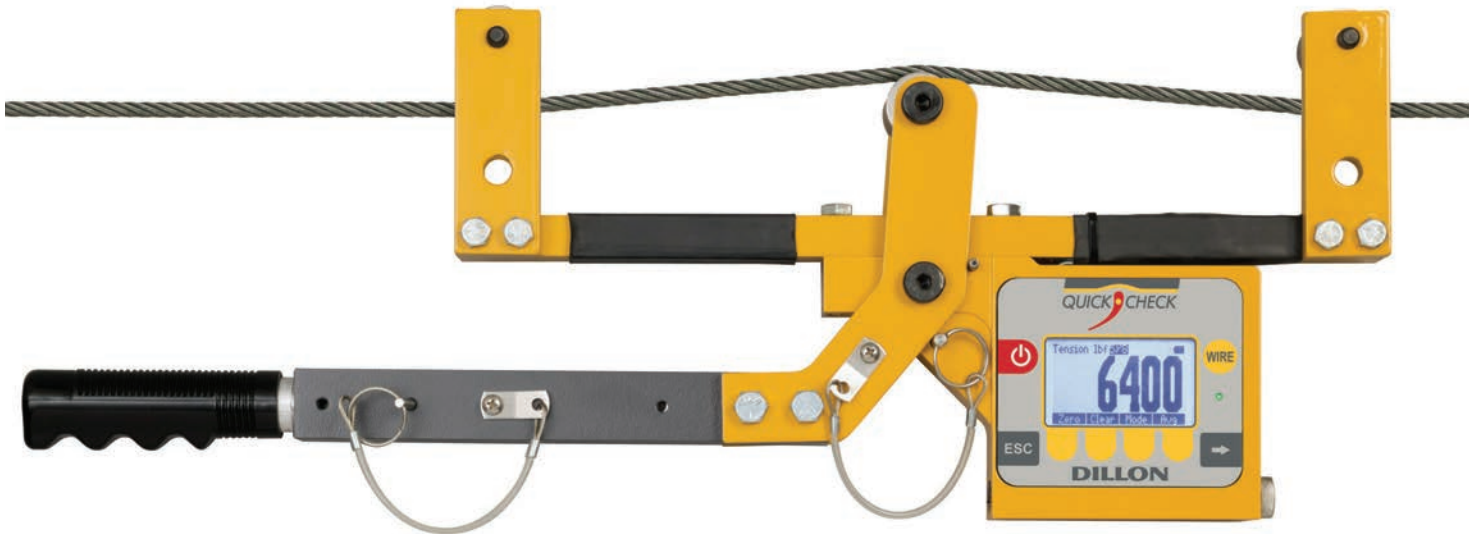

QUICK-CHECK TENSION METER

The Dillon Quick-Check Tension Meter quickly measures tension in cable guardrails, guy lines and overhead wires. It installs, measures and removes in seconds. The digital load cell is highly accurate and requires no lookup or correction tables. Quick Check has 4 available sheave sets and can store up to 20 wire rope calibrations. Specify wire type and diameter when ordering.

PART #	WIRE SIZES	CAPACITY
AWT05-508111	3/16" through 1"	10,000 x 10 lbf

LINE GUN & LUBRICANT APPLICATION KITS

This Line Gun is considered a firearm and must be delivered to a licensed gun dealer. Some exceptions may exist for government entities, police and fire departments.



LINE GUN SHOT LINE

Special nylon waterproof treated floating lines.

PART #	DESCRIPTION	COLOR
NVSL1250-OR	70 lb test / 1250 ft	Orange
NVSL950-OR	70 lb test / 950 ft	Orange
NVSL780-OR	140 lb test / 780 ft	Orange



LINE GUN BRASS PROJECTILES

PART #	QUANTITY
BP10PK	10 Pack

LINE THROWING GUN KIT

Reliable high quality shoulder-fired line thrower for short & long-distance line deployment, ideal for transmission line construction and restoring power when storms or other natural disasters take lines down over rivers or ravines.

Distance 250-700' or more. Line Gun Kit Consists of: Bridge shoulder line gun with line canister, Pelican™ Case with wheels, 10 solid brass projectiles, Qty. (2) 1250'-70 lb., Qty. (2) 950', 70 lb., & Qty. (2) 700' -140 lb shot line, 50 heavy load blank cartridges, Gun oil, cleaning solvent, cleaning rod, brush, Hoppes Boresnake®, plastic instructions, gun lock, safety glasses and ear plugs.

PART #
CG85DU



LUBRICANT APPLICATION TOOL KIT

Easily & safely lubricate a switch without de energizing the entire grid. Kit includes: semi-automatic capsule delivery tool with collapsible stock, laser with on/off switch, offset rail, 2+1 pack with leg strap and tubes, coiled remote with slide check, basic HPA / nitrogen aluminum tank, 42" black zipper case, and HPA / nitrogen fill station.

PART #
TELAT



1003



1004

LUBRICANT APPLICATION CAPSULES

PART #	DESCRIPTION
1003	500 Pro 21 grease filled capsules
1004	500 Tribolube Pro SI oil filled capsules

JUMPER SET COMPONENTS

CLEAR JUMPER CLAMPS (SINGLE)

PART #	RATING	MAIN LINE CAPACITY	AMP CAPACITY
13765	15kV	477 ACSR	400
B1785	35kV	477 ACSR	400
13768	35kV	954 ACSR	400
B2115	35kV	1033 ACSR	400

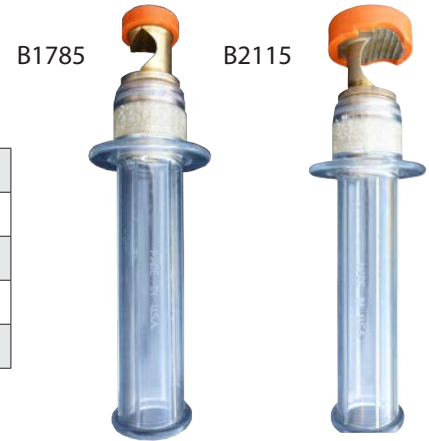

JUMPER FERRULES

Tin-Plated copper jumper ferrules include a nut & lock washer.
One side of the 5/8-11 NC threads are flattened to help secure the clamps' locking screw.

PART #	CABLE SIZE	BURNDY DIE	KEARNEY™ DIE
02T	# 2	U165	9/16
10T	1/0	U243	5/8-1
20T	2/0	U245	11/16
40T	4/0	U247	15/16

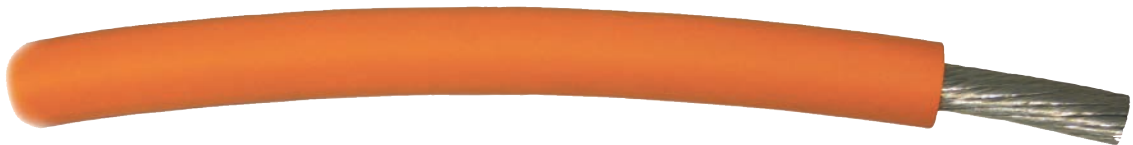

15KV INSULATED JUMPER CABLE

Extremely flexible even at very low temperatures. The EPR jacket resists abrasion, oil, moisture and ozone.

PART #	CABLE SIZE	APPROXIMATE CONDUCTOR DIAMETER	APPROXIMATE AMPACITY RATING	APPROXIMATE WEIGHT PER 1,000 FEET
TEJC02	# 2	.320"	200	440 lbs.
TEJC10	1/0	.403"	250	600 lbs.
TEJC20	2/0	.456"	300	710 lbs.
TEJC40	4/0	.592"	400	1,050 lbs.

25KV INSULATED JUMPER CABLE

PART #	CABLE SIZE	APPROXIMATE CONDUCTOR DIAMETER	APPROXIMATE AMPACITY RATING	APPROXIMATE WEIGHT PER 1,000 FEET
TEJC10-25	1/0	.403"	250	650 lbs.
TEJC20-25	2/0	.456"	300	750 lbs.

35KV INSULATED JUMPER CABLE

PART #	CABLE SIZE	APPROXIMATE CONDUCTOR DIAMETER	APPROXIMATE AMPACITY RATING	APPROXIMATE WEIGHT PER 1,000 FEET
TEJC10-35	1/0	.403"	250	950 lbs.
TEJC20-35	2/0	.480"	300	1,060 lbs.

JUMPER SET ASSEMBLIES



15KV JUMPER SET ASSEMBLIES WITH CLEAR JUMPER CLAMPS

Jumper sets can be made with a specific wire size, to any length using the clear clamps pictured on page 243 and with jumper cable of any rating. All sets include heat shrink tubing over each connection and a dated test label with a unique serial number.

CABLE SIZE	CLAMP	8' LENGTH	10' LENGTH	12' LENGTH	16' LENGTH	20' LENGTH
# 2	13765	TEJ02DD-08	TEJ02DD-10	TEJ02DD-12	TEJ02DD-16	TEJ02DD-20
1/0	B1785	TEJ10UU-08	TEJ10UU-10	TEJ10UU-12	TEJ10UU-16	TEJ10UU-20
2/0	B2115	TEJ20TT-08	TEJ20TT-10	TEJ20TT-12	TEJ20TT-16	TEJ20TT-20
4/0	B2115	TEJ40TT-08	TEJ40TT-10	TEJ40TT-12	TEJ40TT-16	TEJ40TT-20

This designated 3 position Jumper Tester is designed to handle any length jumper and will electrical test any rated jumper up to 35KVAC. The internal 50 KVAC High Voltage Transformer is capable of testing any jumper up to 50 KVAC and will sound an alarm if the jumper encounters any defect, crack or puncture in the insulation. In addition to the audible alarm, the test position of the jumper tester will be visually displayed when a jumper failure has been detected.



LOAD BREAK & LOAD PICKUP TOOLS

LOADBUSTER® LOAD BREAK TOOL

Easy-to-use portable load break tools for use on disconnects, cutouts, power fuses and fuse limiters. It has a built in operation counter and an operating life between 1,500 to 2,000 uses before inspection and maintenance.

PART #	AMPERAGE		VOLTAGE	
	NOMINAL	MAX	NOMINAL	MAX
5300R3	600A	900A	14.4/25kV	27kV
5400R3	600A	900A	25/34.5kV	38kV
5380	Optional carrying case			



5400R3

LOADRANGER® LOAD BREAK TOOL

Weighing under 5 pounds, the XLT line of Load Break Tools are by far the lightest portable load break tools available. It measures 16" long and 6-1/4" wide. The high metal-to-metal clearance minimizes flashover potential. The side located reset button allows for full reset of the tool without glove removal. Options include a Pad Mount version, hard case, soft case, extended insulated hood, and a non-counter version.

PART #	AMPERAGE		VOLTAGE	
	NOMINAL	MAX	NOMINAL	MAX
USLR-XLT-1	600A	900A	14.4/25kV	27kV
USLR-XLT-2	600A	900A	25/34.5kV	38kV



USLR-XLT-1



TENSION PULLER SWITCHING TOOL

This tool permits a live overhead distribution line to be cut preventing service interruption while the work is being performed. It may also be applied whenever disconnect switch is needed for temporary sectionalizing. Maximum ratings 35 kV phase to phase, 600 amps, 4,000 lb line tension.

PART #
C400-1907



ELECTRIC METER JUMPER LEADS

Electric Meter Jumper Lead sets are a convenient and safe method to prevent a customer outage during a meter removal or change-out. Constructed from #6 AWG highly flexible insulated copper and come in four models. Maximum rating 100A, 240VAC.

PART #	DESCRIPTION	QTY
USJL-001	Ferrule end	2
USJL-002	Ferrule end with 100 amp breaker	2

LOAD BREAK & LOAD PICKUP TOOLS

BREAK-SAFE® LOAD BREAK & PICK-UP TOOL

These tools act as a jumper clamp that functions like a portable switch. Designed to operate on overhead distribution lines in conjunction with a mechanical jumper. The Yellow Safety Lock is operated by a hot stick and helps prevent the tool from an unintended load break or pickup operation.

Conductor size: #6 copper to kcmil 954 ACSR. Available with a hard or soft carrying case option.



PART #	MAX VOLTAGE	MAX CURRENT	HEAD STYLE	LENGTH	WEIGHT
USBS-15-1-PS	15kV	300 Amps	Floating	27"	7 lbs.
USBS-15-2-PS	15kV	300 Amps	Duckbill	27"	7 lbs.
USBS-27-1-PS	27kV	300 Amps	Floating	31"	8 lbs.
USBS-27-2-PS	27kV	300 Amps	Duckbill	31"	8 lbs.
USBS-46-1-PS	46kV	200 Amps	Floating	39"	10 lbs.
USBS-46-2-PS	46kV	200 Amps	Duckbill	39"	10 lbs.



LOAD-PICKUP TOOL

Installed on one end of a jumper assembly, this tool can pickup loads and carry 250 amps at 15kV. The spring loaded contacts are closed by pulling on the insulated lanyard. The contacts cannot be re-cocked unless the tool is removed from the conductor. Conductor range of #6 to 795 kcmil ACSR.

This tool cannot be used as a load-break tool.

PART #
C403-1631



TEMPORARY CUTOUT TOOLS

Provides fuse protection during live-line maintenance. The brass stud allows connection of a temporary jumper. Conductor range: #6 solid copper .162 - 1033 kcmil, ACSR 1.25".

PART #	RATING	INTERRUPT CAPACITY	WEIGHT
PSC601-0341	15kV	10,000 Amps	6 lbs.
PSC601-0342	27kV	8,000 Amps	9 lbs.

JACK JUMPER

These tools permit a safe and quick method to bypass standard overhead cutouts without the use of bulky jumper cables. One end is placed on the arcing horn of the cutout and the other to the cradle end of the cutout establishing the bypass. Rated for 100 amps and for standard cutouts.

PART #	CUTOUT RATING	MAX STRETCH
USJJ-001	15kV	9-1/2"
USJJ-002	27kV	14-1/2"

C-TYPE & DUCKBILL GROUNDING CLAMPS



T600-0658



C600-2255



C600-1743



T600-2708

C-TYPE GROUNDING CLAMPS

PART #	JAW TYPE	FERRULE TYPE	MAIN LINE MINIMUM	MAIN LINE MAXIMUM	CONTINUOUS CURRENT	FAULT CURRENT 15 CYCLES	FAULT CURRENT 30 CYCLES
T600-0658	Smooth	Threaded	.162"	2"	400 Amps	43,000 Amps	30,000 Amps
C600-2255	Smooth	Threaded	.162"	2"	400 Amps	43,000 Amps	30,000 Amps
C600-2256	Serrated	Threaded	.162"	2"	400 Amps	43,000 Amps	30,000 Amps
C600-1743	Smooth	Threaded	.162"	1.5"	400 Amps	43,000 Amps	30,000 Amps
T600-2708	Serrated	Threaded	.128"	1.25"	400 Amps	43,000 Amps	30,000 Amps
C600-2276	Serrated	Pressure	.128"	1.25"	400 Amps	43,000 Amps	30,000 Amps
C600-1754	Smooth	Threaded	.128"	.998"	350 Amps	27,000 Amps	20,000 Amps



C600-0197



C600-1734



G3622-1

DUCKBILL-TYPE GROUNDING CLAMPS

PART #	JAW TYPE	FERRULE TYPE	MAIN LINE MINIMUM	MAIN LINE MAXIMUM	CONTINUOUS CURRENT	FAULT CURRENT 15 CYCLES	FAULT CURRENT 30 CYCLES
C600-0197	Serrated	Threaded	.162"	1.506"	400 Amps	43,000 Amps	30,000 Amps
C600-1734	Smooth	Threaded	.162"	1.162"	400 Amps	43,000 Amps	30,000 Amps
G36221	Smooth	Pressure	.162"	1.162"	400 Amps	43,000 Amps	30,000 Amps

SPECIALTY GROUNDING CLAMPS



C600-2100

BALL STUD GROUNDING CLAMPS

Bronze clamps used in restricted-space applications and as part of a truck grounding system. They have a high-current rating of 43,000Ah for 15 cycles and 30,000Ah for 30 cycles.

PART #	TERMINAL TYPE	FERRULE TYPE	HANDLE TYPE
C600-2100	Drilled	Threaded	Shotgun eye
C600-2101	Tapped	Threaded	Shotgun eye
C600-2300	Pressure	Pressure	Shotgun eye
T600-2320	Tapped	Threaded	T-handle



TOWER CLAMP

A bronze body clamp with flat serrated jaws that have a 1-1/2" capacity. It has a drilled terminal to accept threaded ferrules. The fault current rating is 43,000 amps for 15 cycles and 30,000 amps for 30 cycles.



LONG BALL STUD

The 3" shank accepts most types of ground clamps.

PART #
C600-2232

PART #	LENGTH
T600-2364	7"

TOWER CLAMP with a T-Handle.

PART #
C600-2231

STANDARD BALL STUD

PART #	LENGTH
C600-2102	4-1/4"



C-TYPE CLAMP

The smooth jaws of this bronze body clamp accepts up to 477 ACSR (0.814"). It has a shotgun eye handle and uses threaded ferrules. The fault current ratings are 21,000Ah for 15 cycles & 15,000Ah for 30 cycles.

PART #
T600-0466



FLAT FACE CLAMP

This aluminum body clamp has serrated jaws and accommodates up to 1-1/2" angles and flats. It accepts pressure type ferrules and has fault current ratings of 27,000Ah for 15 cycles and 20,000Ah for 30 cycles.

PART #
G33634SJ



BUS-BAR CLAMP

This aluminum clamp fits on square bus up to 4" x 4" and round bus up to 4-1/2" and accepts pressure type ferrules. Fault current rating of 43,000Ah for 15 cycles and 30,000Ah for 30 cycles.

PART #
G3369



PENETRATOR CLAMP

An aluminum body clamp that helps to ensure contact with the center conductor of underground distribution cable. It accommodates conductors up to 2-1/2" and accepts pressure type ferrules.

PART #
T600-1922

GROUNDING FERRULES

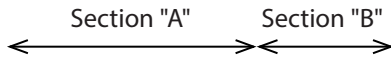

SHROUDED THREADED COPPER FERRULES

PART #	CABLE SIZE	BURNDY DIE "A"	BURNDY DIE "B"
C600-2622	# 2	U165	U166
C600-2623	1/0	U165	U168
C600-2624	2/0	U165	UL
C600-2625	4/0	U166	UL



SHROUDED PLAIN COPPER FERRULES

PART #	CABLE SIZE	BURNDY DIE "A"	BURNDY DIE "B"
C600-2630	# 2	U165	U166
C600-2631	1/0	U165	U168
C600-2632	2/0	U165	UL
C600-2633	4/0	U166	UL



UNSHROUDED THREADED COPPER FERRULES

PART #	CABLE SIZE	BURNDY DIE
C600-2606	# 2	U165
C600-2607	1/0	U165
C600-2608	2/0	U165
C600-2609	4/0	U166



UNSHROUDED PLAIN COPPER FERRULES

PART #	CABLE SIZE	BURNDY DIE
C600-2614	# 2	U165
C600-2615	1/0	U165
C600-2616	2/0	U165
C600-2617	4/0	U166



TIN PLATED COPPER FERRULES

Tin-plated copper jumper ferrules include a nut & lock washer. One side of the 5/8-11 NC threads are flattened to help secure the clamps' locking screw.

PART #	CABLE SIZE	BURNDY DIE	KEARNEY™ DIE
02T	# 2	U165	9/16
10T	1/0	U243	5/8 -1
20T	2/0	U245	11/16
40T	4/0	U247	15/16



5" HEAT SHRINK TUBE

PART #
TEBSTS-5

8" HEAT SHRINK TUBE

PART #
TEBSTS-8

GROUNDING CABLE



BLACK JACKETED TINNED COPPER GROUNDING CABLE

The tinned copper conductor prevents oxidation within the insulation helping to extend the life of the cable.

This flexible cable is made with a TPE insulation and has a voltage rating of 600 volts. Also available with green jacket.

PART #	CABLE SIZE	APPROXIMATE CONDUCTOR DIAMETER	# OF STRANDS
TEG02TB	#2	.323"	665
TEG10TB	1/0	.409"	1045
TEG20TB	2/0	.469"	1330
TEG40TB	4/0	.570"	2109



YELLOW JACKETED TINNED COPPER GROUNDING CABLE

The standard yellow jacket is made with a TPE insulation that is easy to strip and resists abrasion and compression cutting.

This cable stays flexible at temperatures to -40°C and has a 600 volt rating.

PART #	CABLE SIZE	APPROXIMATE CONDUCTOR DIAMETER	# OF STRANDS
TEG02TY	#2	.370"	665
TEG10TY	1/0	.480"	1045
TEG20TY	2/0	.520"	1330
TEG40TY	4/0	.640"	2109



CLEAR JACKETED COPPER GROUNDING CABLE

The clear jacket allows for visual inspection of the conductor under the insulation.

Extremely flexible at temperatures ranging from -25°C to 90°C. Meets ASTM B-3 & F-855 specifications.

PART #	CABLE SIZE	APPROXIMATE CONDUCTOR DIAMETER	# OF STRANDS
TEG02CC	#2	.326"	665
TEG10CC	1/0	.443"	1050
TEG20CC	2/0	.491"	1323
TEG40CC	4/0	.619"	2107

STANDARD GROUND SETS

TALLMAN CAN **CLEAN, TEST AND CERTIFY** YOUR USED GROUND SETS.

Our standard ground sets are made with threaded, tin-plated copper ferrules. Clear heat-shrink tubing covers the connection between the wire and ferrule. Standard ground sets can be ordered in any length. Each ground set is labeled with the date of test and assembly along with a unique serial number. Your company labels and serial numbers can be used.

BLACK JACKETED TIN-PLATED COPPER WIRE GROUND SETS

Standard ground sets made with #2 and 1/0 cable are supplied with 1-1/4" capacity clamps. Larger ground sets are supplied with 2" clamps.

CABLE SIZE	8' LENGTH	10' LENGTH	20' LENGTH
#2	TEG02BR2R2-08	TEG02BR2R2-10	TEG02BR2R2-20
1/0	TEG10BR2R2-08	TEG10BR2R2-10	TEG10BR2R2-20
2/0	TEG20BAA-08	TEG20BAA-10	TEG20BAA-20
4/0	TEG40BAA-08	TEG40BAA-10	TEG40BAA-20



Shown with 1-1/4" clamps.

YELLOW JACKETED TIN PLATED COPPER WIRE GROUND SETS

Standard ground sets made with #2 and 1/0 cable are supplied with 1-1/4" capacity clamps. Larger ground sets are supplied with 2" clamps.

CABLE SIZE	8' LENGTH	10' LENGTH	20' LENGTH
#2	TEG02YR2R2-08	TEG02YR2R2-10	TEG02YR2R2-20
1/0	TEG10YR2R2-08	TEG10YR2R2-10	TEG10YR2R2-20
2/0	TEG20YAA-08	TEG20YAA-10	TEG20YAA-20
4/0	TEG40YAA-08	TEG40YAA-10	TEG40YAA-20



Shown with 2" clamps.

CLEAR JACKETED COPPER WIRE GROUND SETS

Standard ground sets made with #2 and 1/0 cable are supplied with 1-1/4" capacity clamps. Larger ground sets are supplied with 2" clamps.

CABLE SIZE	8' LENGTH	10' LENGTH	20' LENGTH
# 2	TEG02CR2R2-08	TEG02CR2R2-10	TEG02CR2R2-20
1/0	TEG10CR2R2-08	TEG10CR2R2-10	TEG10CR2R2-20
2/0	TEG20CAA-08	TEG20CAA-10	TEG20CAA-20
4/0	TEG40CAA-08	TEG40CAA-10	TEG40CAA-20



Shown with 2" clamps.

CUSTOM GROUND SETS

CUSTOM MADE GROUNDING SETS

Most ground sets made with in stock components can ship within 24 hours.
Ball socket & truck grounding sets, live-front switches & transformers, overhead transmission & distribution systems
and elbow grounds for single & three phase transformers.

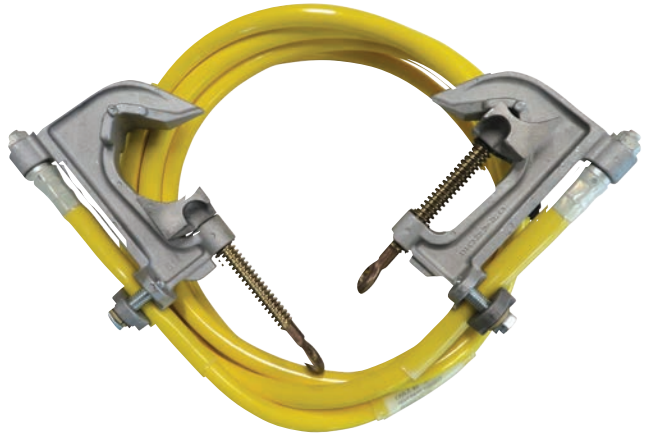

All ground sets are electrically tested and serialized prior to shipment.



BREAKAWAY BONDING SLEEVE

PART #

BAC625

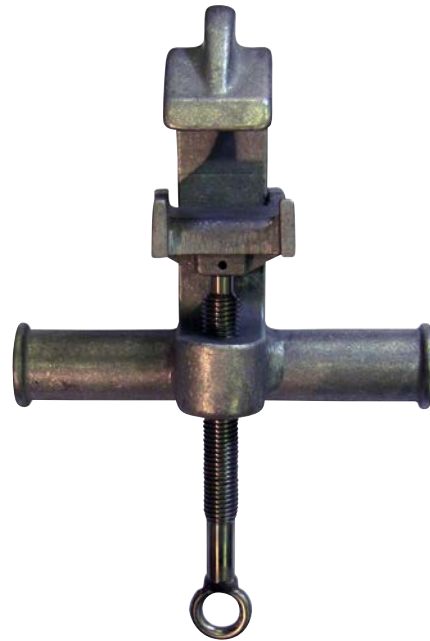

**TWISTED PAIR GROUND CLAMPS
WITH HANGER STUDS**

Capacity of 2-3/0 ACSR-T2 through 2-1113 ACSR-T2.
Meets ASTM 855 Class 7 standard.

PART #

TETPGC-1

SPECIALTY GROUND SETS



All elbow ground sets are electrically tested and serialized prior to shipment.

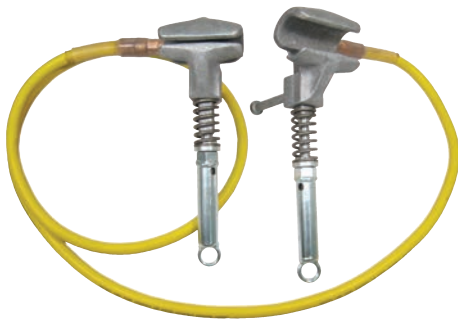

CONCENTRIC NEUTRAL JUMPER SET

Used for bonding purposes on non-jacketed cable, it is installed across the portion of the cable to be cut, repaired or spliced. The assembly is left in place until the concentric neutral has been spliced. Made with 8' of 2/0 yellow jacketed cable and 2 spring loaded ground clamps. This set has a continuous current rating of 250 amps and a fault current rating of 14,000 amps for 15 cycles.

PART #
76038YC



GROUNDING ELBOW

PART #	RATING
C600-3097	15kV
C600-3098	25/35kV
C600-3099	35kV



SINGLE-PHASE ELBOW GROUNDING SETS

Made with 6 feet of 1/0 yellow jacketed cable and a bronze body C-Type ground clamp on one end and an elbow on the other end.

15KV ELBOW GROUNDING SET
PART #
TEG10YRV-06

25/35KV ELBOW GROUNDING SET
PART #
TEG10YRW-06



GROUNDING PARKING BUSHING SETS

A load break bushing on one end and bronze body clamp on the other end of a 4' length of 1/0 yellow jacketed cable.

15KV GROUNDED PARKING BUSHING SET
PART #
T600-3091

25/35KV GROUNDED PARKING BUSHING SET
PART #
T600-3092



THREE-PHASE ELBOW GROUNDING SETS

Three 6' lengths of 1/0 yellow jacketed cable connected to a single C-Type bronze body ground clamp with elbows on the other ends.

15KV 3-PHASE ELBOW GROUNDING SET
PART #
TEG10YG3V-06

25/35KV 3-PHASE ELBOW GROUNDING SET
PART #
TEG10YG3W-06

SPECIALTY GROUND SETS

Temporary grounding sets for live-front switches and transformers. Your choice of clamps include flat-face, ball stud clamps or c-clamps. Available in any cable size, color or length.



4-LEG GROUNDING SET

Consists of three 4 foot and one 6 foot lengths of 1/0 clear cable. Includes a 4-way terminal block and 4 flat face grounding clamps. Fault current ratings: 21,000 amps for 15 cycles and 15,000 amps for 30 cycles.

PART #
T600-2375



3-LEG GROUNDING SET

Bronze clamps on three 6 foot lengths of 1/0 clear cable are connected to a 3-way terminal block with a fourth c-clamp. Fault current ratings: 21,500 amps for 15 cycles and 15,000 amps for 30 cycles.

PART #
C600-0758



BALL STUD GROUNDING SET

Ball stud clamps on three 6 foot lengths of 2/0 clear cable are connected to a 3-way terminal block with a fourth ball stud clamp. 4 ball studs are included. Fault current ratings: 27,000 amps for 15 cycles and 20,000 amps for 30 cycles.

PART #
T600-2246



VINYL GROUND SET BAGS

PART #	SIZE
TE2177	20" x 5" x 32"
TE2178	26" x 29"

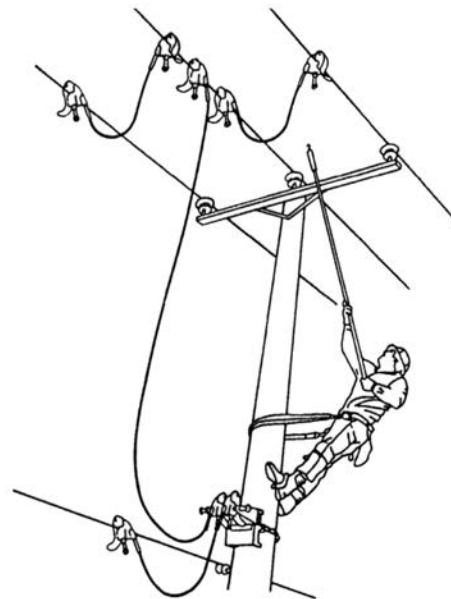

CUSTOM MADE OVERHEAD DISTRIBUTION GROUNDING SETS

Generally consisting of 5 assembled lengths, these sets may include three lengths at 6' each, one at 12' and one at 30'. These complete sets are made to your specifications using your choice of cable, ferrules, clamps and overall lengths. All sets are tested and labeled with the date of test and their own unique serial number.

TRUCK GROUNDING

Picture below shows the grounding assembly using GR43BS2 and DNG2B2M during a typical conductor installation.

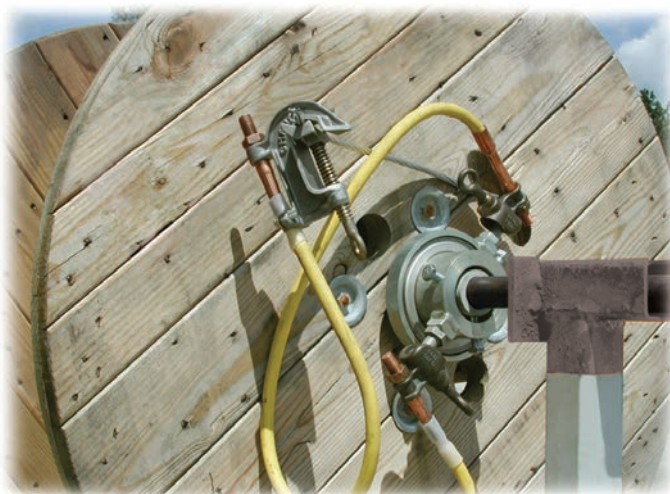

ROTATING GROUND ADAPTER

This unique tool provides protection while the conductor is pulled from reels. It adds conductor grounding but does not replace other grounding practices. The adapter slides on the reel mandrel. The outer collar connects to the tail of the conductor on the reel and the inner collar connects to a ground rod.

PART #
GR43BS2

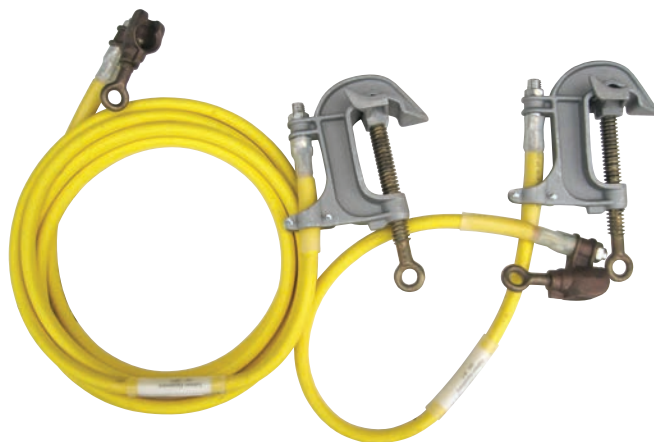

CABLE REEL GROUNDING SET

Consisting of a 3' length and a 15' length of 2/0 yellow jacketed cable, both with ball stud clamps on one end and C-type clamps on the other.

PART #
TEG2B2M

TRUCK GROUNDING REELS

Provides an efficient and positive means to ground trucks near energized electrical lines. Each reel with factory installed cable includes a 6' length of 2/0 ground cable to connect to the truck and a bronze body clamp to attach to the ground rod.

PART #	DESCRIPTION
21364	Grounding reel with 40' of 1/0 cable and clamp
21365	Grounding reel with 40' of 2/0 cable and clamp
21374	Grounding reel with 50' of 1/0 cable and clamp
21375	Grounding reel with 50' of 2/0 cable and clamp

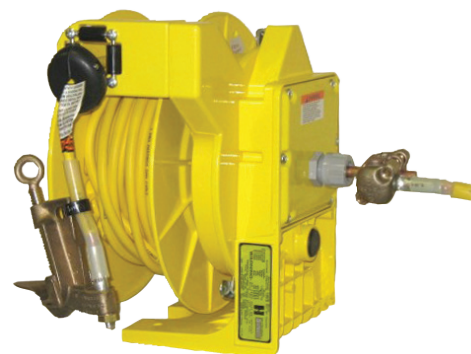



ANTI-SKID PROTECTIVE GROUND MAT

Provides an anti-skid method for workers to establish an equal potential zone for multiple grounding applications.

PART #	DESCRIPTION	COLOR
6610	58" x 58" protective ground mat	Yellow
6615	58" x 120" protective ground mat	Yellow
6620	120" x 120" protective ground mat	Yellow

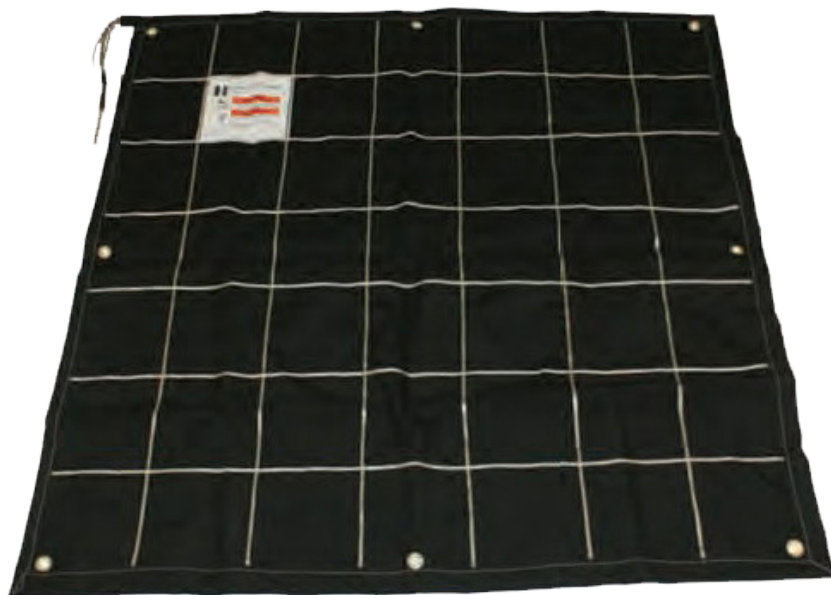

ANTI-SKID PROTECTIVE GROUND MAT

Provides an anti-skid method for workers to establish an equal potential zone for multiple grounding applications.

PART #	DESCRIPTION	COLOR
6610-NS	58" x 58" protective ground mat	Black
6615-NS	58" x 120" protective ground mat	Black
6620-NS	120" x 120" protective ground mat	Black

PERSONAL PROTECTIVE GROUND GRIDS



Mechanical Equipment (Vehicles, etc.) Grounding

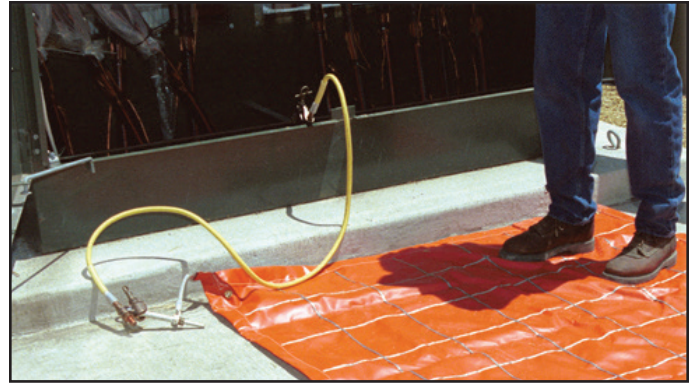

Pad Mounted Transformers and Switches



PSCC600-3348



Protective Grid Kit



C600-3080



Overhead Distribution and Transmission Switches

PROTECTIVE GRID

Complies with OSHA 1910.269 for equipotential requirements near vehicles, underground gear, overhead switches and in substations. Meets ASTM F2715 standard. Includes a Long Ball Stud and illustrated instructions.

PART #	SIZE	DESCRIPTION
C600-2850	58" x 58"	Orange - long ball stud only
C600-2851	58" x 120"	Orange - long ball stud only
C600-2852	120" x 120"	Orange - long ball stud only
C600-3080	24" x 24"	Orange - long ball stud only - bucket
PSC600-3345	58" x 58"	Black - non-slip grid - long ball stud only
PSC600-3346	58" x 120"	Black - non-slip grid - long ball stud only
PSC600-3347	120" x 120"	Black - non-slip grid - long ball stud only

PROTECTIVE GRID KITS

Each kit includes ground grid with long ball stud and illustrated instructions, ground set with 6' length of #2 grounding cable (with a c-clamp on one end and a ball socket clamp on the other end) and a vinyl storage bag.

PART #	SIZE	DESCRIPTION
C600-2989	58" x 58"	Orange - protective grid kit
C600-2990	58" x 120"	Orange - protective grid kit
C600-2991	120" x 120"	Orange - protective grid kit
PSC600-3348	58" x 58"	Black - non-slip protective grid kit
PSC600-3349	58" x 120"	Black - non-slip protective grid kit
PSC600-3350	120" x 120"	Black - non-slip protective grid kit



CLUSTER BAR

The 5/8" x 5" aluminum bar accepts ground clamps for equipotential grounding techniques. Supplied with an adjustable wheel binder and 36" of chain for poles.

PART #

6767



CLUSTER BRACKET

12" long 3/4" grounding bar with four 1" spikes for surface contact to pole. Mounted vertically or horizontally with 5/8" bolt. 43kA for 15 cycles fault current rating. 400A continuous current rating.

PART #

CPB-DE

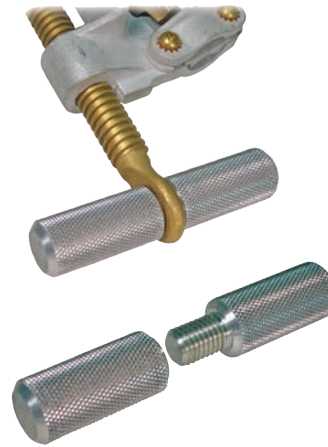

T-HANDLE ADAPTER

Converts the shotgun eye of a ground clamp into a T-Handle.

PART #

DNGCTH



4-WAY

TERMINAL BLOCK

Used to attach ground leads from grounding clamps to a common ground. Accepts unthreaded ferrules only.

PART #

G47541



TEMPORARY GROUND ROD

A temporary 6' copper clad ground rod with T-Handle.

PART #

DNTGR



GROUND ROD DRIVER

Simple design and function, this hammer-action ground rod driver weighs 24 lbs. The body length is 33" and has a 29" stroke.

PART #

TEMGRD-2



INSULATED HANGER

Used as a parking stand when installing jumper or grounding clamps. It has a 15" Epoxiglas pole and a conductor capacity of 636 ACSR. Studs are 1/2" x 3-1/2".

PART #

S16007



DISCHARGE STICK

A fiberglass stick with a 10' green jacketed cable and ground clamp that will let the utility worker temporarily bond non-insulated baskets and equipment between grounded bus work and conductors in the area where they are working.

PART #

DHCFT-442G10-4

CONDUCTOR CLEANING BRUSHES



CONDUCTOR CLEANING BRUSH

A spring loaded shotgun attachment that offers an easier and more effective cleaning action than a simple hand held brush.

PART #	DESCRIPTION
USCC-004	3"-11" Diameter conductor cleaner tool
USCC-005	Replacement brush pad set for Part # USCC-004
USCC-006	3/4"-3" Diameter conductor cleaner tool
USCC-007	Replacement brushes for Part # USCC-006



FLEXIBLE CONDUCTOR BRUSH

The flexibility of this brush allows cleaning of almost any size conductor.

PART #	SIZE
TEFCB100	1-1/2" wide



UNIVERSAL CONDUCTOR BRUSH

PART #	SIZE
M4455-92	1-1/4" Dia. x 6" L



CONDUCTOR BRUSH

PART #	SIZE
M4455-93	1-1/4" Dia. x 6"



UNIVERSAL CONDUCTOR V-BRUSH

PART #
10-180



CONDUCTOR V-BRUSH

With shotgun eye.

PART #
10-178



REPLACEMENT BRUSHES

For both 10-178 and 10-180 V-Brushes.

PART #	DESCRIPTION
10-179	Box of 10 brushes

PSC-1 & PSC-1HD PRE SPLICE CUTTERS

Made of an aluminum alloy, DDIN Pre Splice Cutters are lightweight and durable. Used to quickly and accurately remove the aluminum stranding around the steel core of ACSR, ACSS and other types of conductor. Operating like a tubing cutter, they squarely and cleanly cut aluminum stranding without harming the inner steel strands.



PSC-1
See page 398 for repair parts.



PSC-1HD



The PSC-1HD case holds eighteen TE style bushings.

ACSR PRE SPLICE CUTTER

(1) Molded case, (1) PSC-1 Cutting tool, (1) Bushing holder.

PART #	WEIGHT
PSC-1	1.65 lbs.

HEAVY DUTY ACSR PRE SPLICE CUTTER

(1) Heavy duty case, (1) PSC-1HD cutting tool, (1) Additional Axle screw, (1) Additional cutting wheel, (1) Bushing holder.

PART #	WEIGHT
PSC-1HD	2.5 lbs.

PSC-1 & PSC-1HD BUSHINGS

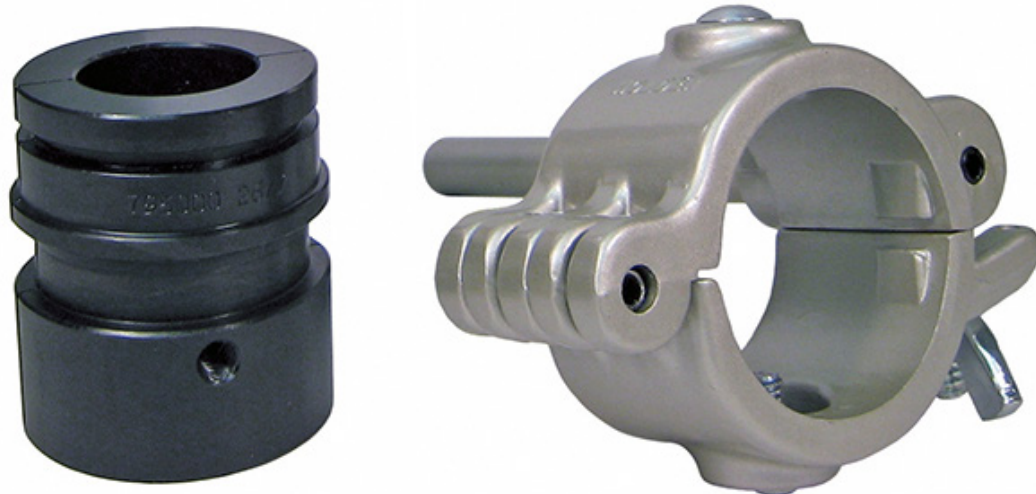

PSC-1 & PSC-1HD BUSHINGS

These interchangeable bushings are precision machined to accurately trim the outer stranding of one particular wire only. If you don't see what you need we can manufacture any bushing for any wire size, contact us for more information 877-860-5666.

PART #	CODE WORD	CIRCULAR MILLS / AWG	STRANDING	WIRE TYPE
TE5755	Swanate	4	7/1	ACSR
TE5759	Robin	1	6/1	ACSR
TE5761	Quail	2/0	6/1	ACSR
TE5762	Pigeon	3/0	6/1	ACSR
TE5763	Penguin	4/0	6/1	ACSR
TE5764	Waxwing	266.8	18/1	ACSR
TE5766	Partridge	266.8	26/7	ACSR/ACSS
TE5767	Ostrich	300.0	26/7	ACSR/ACSS
TE5768	Merlin	336.4	18/1	ACSR
TE5769	Linnet	336.4	26/7	ACSR/ACSS
TE5770	Oriole	336.4	30/7	ACSR/ACSS
TE5771	Chickadee	397.5	18/1	ACSR
TE5772	Brant	397.5	24/7	ACSR/ACSS
TE5773	Ibis	397.5	26/7	ACSR/ACSS
TE5774	Lark	397.5	30/7	ACSR/ACSS
TE5775	Pelican	477	18/1	ACSR
TE5776	Flicker	477	24/7	ACSR/ACSS
TE5777	Hawk	477	26/7	ACSR/ACSS
TE5778	Hen	477	30/7	ACSR/ACSS
TE5779	Osprey	556.5	18/1	ACSR
TE5780	Parakeet	556.5	24/7	ACSR/ACSS
TE5781	Dove	556.5	26/7	ACSR/ACSS
TE5782	Eagle	556.5	30/7	ACSR/ACSS

PSC-1 & PSC-1HD BUSHINGS

BUSHINGS FOR PSC-1 & PSC-1HD PRE SPLICE CUTTERS

These interchangeable bushings are precision machined to accurately trim the outer stranding of one particular wire only.

PART #	CODE WORD	CIRCULAR MILLS / AWG	STRANDING	WIRE TYPE
TE5784	Squab	605	26/7	ACSR/ACSS
TE5785	Teal	605	30/19	ACSR/ACSS
TE5786	Swift	636	36/1	ACSR
TE5787	Kingbird	636	18/1	ACSR
TE5788	Rook	636	24/7	ACSR
TE5789	Grosbeak	636	26/7	ACSR/ACSS
TE5790	Egret	636	30/19	ACSR/ACSS
TE5791		653.9	18/3	ACSR
TE5792	Flamingo	666.6	24/7	ACSR/ACSS
TE5793	Stilt	715.5	24/7	ACSR/ACSS
TE5794	Starling	715.5	26/7	ACSR/ACSS
TE5795	Redwing	715.5	30/19	ACSR/ACSS
TE5796	Coot	795	36/1	ACSR
TE5797	Tern	795	45/7	ACSR/ACSS
TE5799	Condor	795	54/7	ACSR/ACSS
TE5800	Drake	795	26/7	ACSR/ACSS
TE5801	Mallard	795	30/19	ACSR/ACSS
TE5802	Ruddy	900	45/7	ACSR/ACSS
TE5803	Canary	900	54/7	ACSR/ACSS
TE5804	Catbird	954	36/1	ACSR
TE5805	Rail	954	45/7	ACSR/ACSS
TE5806	Cardinal	954	54/7	ACSR/ACSS
TE5808	Ortolan	1033.5	45/7	ACSR/ACSS
TE5809	Curlew	1033.5	54/7	ACSR/ACSS
TE5810	Bluejay	1113	45/7	ACSR/ACSS
TE5811	Finch	1113	54/19	ACSR/ACSS
TE5812	Bunting	1192.5	45/7	ACSR/ACSS
TE5813	Grackle	1192.5	54/19	ACSR
TE5814	Bittern	1272	45/7	ACSR/ACSS
TE5815	Pheasant	1272	54/19	ACSR/ACSS
TE5816	Dipper	1351.5	45/7	ACSR/ACSS
TE5817	Martin	1351.5	54/19	ACSR/ACSS
TE5818	Bobolink	1431	45/7	ACSR/ACSS
TE5819	Plover	1431	54/19	ACSS
TE5820	Nuthatch	1510	45/7	ACSS
TE5821	Parrot	1510	54/19	ACSS
TE5822	Lapwing	1590	45/7	ACSR/ACSS
TE5823	Hornbill	1590	48/7	ACSR-AW
TE5824	Chukar	1780	84/19	ACSR/ACSS
TE5825	Grouse	80	8/1	ACSR

PSC-1 & PSC-1HD BUSHINGS

BUSHINGS FOR PSC-1 & PSC-1HD PRE SPLICE CUTTERS

These interchangeable bushings are precision machined to accurately trim the outer stranding of one particular wire only.

PART #	CODE WORD	CIRCULAR MILLS / AWG	STRANDING	WIRE TYPE
TE5826	Petrel	101.8	12/7	ACSR
TE5827	Minorca	110.8	12/7	ACSR
TE5828	Leghorn	134.6	12/7	ACSR
TE5829	Guinea	159	12/7	ACSR
TE5830	Dotterel	176.9	12/7	ACSR
TE5831	Dorking	190.8	12/7	ACSR
TE5832	Cochin	211.3	12/7	ACSR
TE5842	Peacock	605	24/7	ACSR/ACSS
TE5860	Falcon	1590	54/19	ACSR/ACSS
TE5883	Canvasback	954	30/19	ACSS
TE5900	Raven	1/0	6/1	ACSR
TE5987	Towhee	954	48/7	ACSS
TE6123	Pippit	636	5	ACSR-SD
TE6124	Killdeer	636	7	ACSR-SD
TE6133	Phoenix	954	5	ACSR-SD
TE6203	Hawk	477	18/7	ACSR-TW/ACSS-TW
TE6204	Parakeet	556.5	18/7	ACSR-TW/ACSS-TW
TE6205	Dove	556.5	20/7	ACSR-TW/ACSS-TW
TE6208	Grosbeak	636	20/7	ACSR-TW/ACSS-TW
TE6212	Drake	795	20/7	ACSR-TW/ACSS-TW
TE6215	Cardinal	954	20/7	ACSR-TW/ACSS-TW
TE6218	Curlew	1033.5	20/7	ACSR-TW/ACSS-TW
TE6224	Grackle	1192.5	38/19	ACSR-TW/ACSS-TW
TE6226	Bittern	1272	35/7	ACSR-TW/ACSS-TW
TE6227	Pheasant	1272	39/19	ACSR-TW/ACSS-TW
TE6229	Martin	1351	39/19	ACSR-TW/ACSS-TW
TE6230	Bobolink	1431	36/7	ACSR-TW/ACSS-TW
TE6233	Falcon	1590	42/19	ACSR-TW/ACSS-TW
TE6234	Chukar	1780	37/19	ACSR-TW/ACSS-TW
TE6235	Bluebird	2156	64/19	ACSR-TW/ACSS-TW
TE6237	Mohawk	571.7	18/7	ACSR-TW/ACSS-TW
TE6238	Calumet	565.3	18/7	ACSR-TW/ACSS-TW
TE6240	Oswego	664.8	20/7	ACSR-TW/ACSS-TW
TE6242	Maumee	768.2	20/7	ACSR-TW/ACSS-TW
TE6243	Wabash	762.8	20/7	ACSR-TW/ACSS-TW
TE6245	Fraser	946.7	35/7	ACSR-TW/ACSS-TW
TE6247	Suwannee	959.6	22/7	ACSR-TW/ACSS-TW
TE6249	Genesee	1158	33/7	ACSR-TW/ACSS-TW
TE6250	Hudson	1158.4	26/7	ACSR-TW/ACSS-TW
TE6253	Yukon	1233.6	38/19	ACSR-TW/ACSS-TW

PSC-1 & PSC-1HD BUSHINGS

BUSHINGS FOR PSC-1 & PSC-1HD PRE SPLICE CUTTERS

These interchangeable bushings are precision machined to accurately trim the outer stranding of one particular wire only.

PART #	CODE WORD	CIRCULAR MILLS / AWG	STRANDING	WIRE TYPE
TE6261	Potomac	1557.4	36/7	ACSR-TW/ACSS-TW
TE6262	Rio Grande	1533.3	39/19	ACSR-TW/ACSS-TW
TE6264	Pecos	1622	39/19	ACSR-TW/ACSS-TW
TE6267	Athabaska	1949.6	42/7	ACSR-TW/ACSS-TW
TE6268	Cumberland	1926.9	42/19	ACSR-TW/ACSS-TW
TE6277	Scoter	636	18/7	ACSS-TW/HS285
TE6280	Toutle	795	17/7	ACSR-TW
TE6281	Mallard	795	20/7	ACSS-TW
TE6306	Grosbeak	636	20/7	ACSS-TW
TE6322	Grackle	1192.5	38/19	ACSS-TW
TE6339	Wabash	762.8	20/7	ACSS-TW
TE6344	Cheyenne	1168.1	30/7	ACSS-TW
TE6346	Hudson	1158.4	26/7	ACSS-TW
TE6350	Truckee	1372.5	30/7	ACSS-TW
TE6351	Mackenzie	1359.7	36/7	ACSS-TW
TE6352	Thames	1334.6	39/19	ACSS-TW
TE6355	Merrimack	1433.6	39/19	ACSS-TW
TE6365	Powder	2153.8	64/19	ACSS-TW
TE6375	Lemon / Darts	261.5 mm ²	30/7	ACSR-GZ / ACSR-AC AUSTRALIAN
TE7002	Squirrel	20 mm ²	6/1	ACSR BRITISH
TE7004	Goat	300 mm ²	30/7	ACSR BRITISH
TE7006	Ferret	40 mm ²	6/1	ACSR BRITISH
TE7008	Mink	60 mm ²	6/1	ACSR BRITISH
TE7009	Skunk	60 mm ²	12/7	ACSR BRITISH
TE7010	Zebra	400 mm ²	54/7	ACSR BRITISH
TE7012	Racoon	75 mm ²	6/1	ACSR BRITISH
TE7016	Dog	100 mm ²	6/7	ACSR BRITISH
TE7017	Hyena	100 mm ²	7/7	ACSR BRITISH
TE7019	Coyote	125 mm ²	26/7	ACSR BRITISH
TE7021	Wolf	150 mm ²	30/7	ACSR BRITISH
TE7022	Lynx	175 mm ²	30/7	ACSR BRITISH
TE7024	Lion	225 mm ²	30/7	ACSR BRITISH
TE7025	Bear	250 mm ²	30/7	ACSR BRITISH
TE7029	Bison	350 mm ²	54/7	ACSR BRITISH
TE7039	Batang	300 mm ²	18/7	ACSR BRITISH
TE7210	Crane	443.1 mm ²	13/7	ACSR CANADIAN
TE7262	Scissortail	644.5 mm ²	42/7	ACSR CANADIAN
TE7290	Peace	316.1 mm ²	48/7	ACSR CANADIAN

PSC-2HD CUTTER & BUSHINGS



LARGE DIAMETER HEAVY DUTY PRE SPLICE CUTTER

(1) Heavy duty case, (1) PSC-2HD cutting tool,
(2) additional axle screws, (2) additional cutting wheels.

PART #	WEIGHT
PSC-2HD	2.5 lbs.



PSC-2HD



Heavy duty case
holds six TD style bushings



PSC-2HD BUSHINGS

This list is a small sample of available bushings.

PART #	CODE WORD	CIRCULAR MILLS / AWG	STRANDING	WIRE TYPE
TD1604		1843	72/7	1.6 COMPACT
TD1605	Bluebird	2156	84/19	ACSR/ACSS
TD1608		2332.8	72/19	
TD1609	Kiwi	2167	72/7	ACSR/ACSS
TD1610	Mockingbird	2034.5	72/7	ACSS
TD1611		2493	54/37	
TD1612		2070	92/19	AACSR
TD1615	Thrasher	2312	76/19	ACSS
TD1616		25150	76/19	
TD1621	573 R	460.7 mm ²	28/19	ACSS/TW
TD1623	883 R	711.4 mm ²	29/19	ACSS/TW
TD1630		1851-T13	54/19	ACCR
TD5822	Lapwing	1590	45/7	ACSR/ACSS
TD5823	Hornbill	1590	48/7	ACSR/AW
TD5824	Chukar	1780	84/19	ACSR/ACSS
TD5860	Falcon	1590	54/19	ACSR/ACSS
TD62BPA	Deschutes	1519	30/7	ACSR-TW



**LARGE DIAMETER
HEAVY DUTY PRE SPLICE CUTTER**

(1) Heavy duty case, (1) PSC-3HD cutting tool,
(2) additional axle screws, (2) additional cutting wheels

PART #	WEIGHT
PSC-3HD	2.5 lbs.

**LARGE DIAMETER
HEAVY DUTY PRE SPLICE CUTTER**

(1) Molded case, (1) PSC-4HD cutting tool

PART #	WEIGHT
PSC-4HD	2.5 lbs.

PSC-3HD BUSHINGS

PART #	CODE WORD	CIRCULAR MILLS / AWG	STRANDING	WIRE TYPE
TC1619	Santee	2627.3	64/19	ACSR TW / ACSS TW
TC1625	1317R	460.7 mm ²	48/37	ACSS/TW
TC1626	687R	536 mm ²	28/19	ACSS/TW

PSC-4HD BUSHINGS

PART #	CODE WORD	CIRCULAR MILLS / AWG	STRANDING	WIRE TYPE
TB1600		3633	110/7	ACSR

BOLT CUTTERS

GENERAL PURPOSE

These center cut bolt cutters feature a toggle joint that turns 50 lbs. of hand pressure into 4,000 lbs. of cutting pressure. A lock plate keeps the steel jaws from loosening and a screw-type adjustment realigns the edges.



STEEL HANDLE

PART #	MEDIUM HARD MATERIALS*	HARD MATERIALS**	LENGTH	REPL HEAD
1490MC	5/16"	3/16"	14"	1413C
0090MC	3/8"	1/4"	18"	0013C
0190MC	7/16"	5/16"	24"	0113C
0290MC	1/2"	3/8"	30"	0213C
0390MC	9/16"	7/16"	36"	0313C
0590MC	11/16"	1/2"	42"	0513C

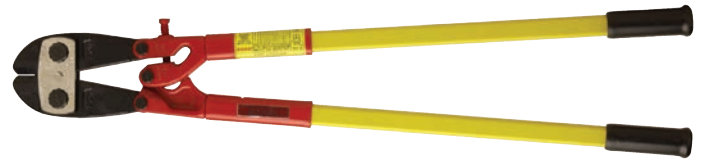

FIBERGLASS HANDLE

PART #	MEDIUM HARD MATERIALS*	HARD MATERIALS**	LENGTH	REPL HEAD
0090FC	3/8"	1/4"	18"	0013C
0190FC	7/16"	5/16"	24"	0113C
0290FC	1/2"	3/8"	30"	0213C
0390FC	9/16"	7/16"	36"	0313C

* Brinell 300 Rockwell C31

** Brinell 455, Rockwell C38

ROUND HANDLE BOLT CUTTERS

The jaws are made from forged high tensile steel. Designed for cutting spring wire, guy wire, hardened chains, high tensile bolts and other hard materials.

The handles are filled with unicellular foam and tested to ASTM standards.

PART #	SOFT MATERIALS	MEDIUM MATERIALS	HARD MATERIALS	LENGTH	REPLACEMENT HEAD
BC14F	1/4"	1/4"	3/16"	14"	BC14RB
BC18F	5/16"	1/4"	1/4"	18"	BC18RB
BC24F	3/8"	5/16"	5/16"	24"	BC24RB
BC30F	1/2"	3/8"	11/32"	30"	BC30RB
BC36F	5/8"	15/32"	3/8"	36"	BC36RB



BC24F

HEAVY-DUTY BOLT CUTTERS

Heavy-duty cutters are used for cutting hard metals, wire mesh and reinforcing rod & rebar. The jaws are supported with heavy-duty straps. Like the above tools, they provide 4,000 lbs. of cutting force from 50 lbs. of hand pressure.



HEAVY-DUTY STEEL HANDLE

PART #	HARD MATERIALS**	LENGTH	REPLACEMENT HEAD
0190MCX	5/16"	24"	0113CX
0290MCX	3/8"	30"	0213CX
0390MCX	7/16"	36"	0313CX
0590MCX	1/2"	42"	0513CX



HEAVY-DUTY FIBERGLASS HANDLE

PART #	HARD MATERIALS**	LENGTH	REPLACEMENT HEAD
0190FCX	5/16"	24"	0113CX
0290FCX	3/8"	30"	0213CX
0390FCX	7/16"	36"	0313CX

** Brinell 455, Rockwell C48

HEAVY-DUTY CABLE CUTTERS



COMPACT CABLE CUTTERS

High-leverage jaws with shear-cut blades. These cutters have plastic covered, non-slip grips and fit into most tool pouches.

PART #	CU CABLE	AL CABLE	LENGTH
0890CSJ	2/0	4/0	9"

DO NOT USE TO CUT ACSR OR STEEL.

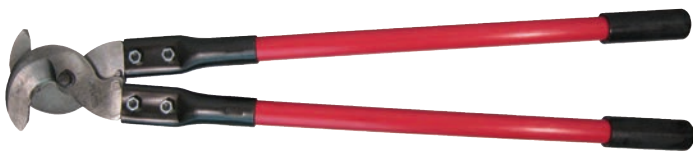

CC-1000



0290FCS

SHEAR TYPE CABLE CUTTERS

Lightweight fiberglass handles with alloy steel jaws. Used to cut soft aluminum, copper and communications cable.

PART #	CAPACITY	COMMUNICATION CABLE	WEIGHT	LENGTH	REPLACEMENT BLADE
CC-500	600 MCM Cu / 600 MCM Al	1-3/8"	3.5 lbs.	21"	500HA
CC-1000	1000 MCM Cu / 1200 MCM Al	1-3/4"	9 lbs.	32"	1000HA
0290FCS	500 MCM Cu / 750 MCM Al	1-3/8"	4.5 lbs.	25-1/2"	0213CSS
0390FCS	750 MCM Cu / 1200 MCM Al	1-3/4"	6 lbs.	32"	0313FCS



SHEAR TYPE WIRE ROPE CUTTERS

Heavy-duty cutters with steel handles. Notched, shear-cut blades holds and lock in cutting position. Cuts wire rope, hard stainless steel cable and aircraft cable with minimal distortion.

PART #	CAPACITY	LENGTH	REPLACEMENT HEAD
1490MTN	1/4"	14"	1413TN
0190MTN	3/8"	24"	0113TN
0390MTN	5/8"	36"	0313TN
0590MTN	3/4"	42"	0513TN

SHEAR TYPE

COMMUNICATIONS CABLE CUTTERS

Communications cable cutters with steel handles. Blades give a clean, sharp cut with minimal distortion.

PART #	CAPACITY	LENGTH	REPLACEMENT HEAD
0190CSP	1"	23"	0119CSP
0390CSP	2-1/4"	37"	0319CSS

DO NOT USE TO CUT HARD CABLE, ACSR, SELF-SUPPORTING STRAND OR STEEL.

CABLE RATCHET CUTTERS



8690FH



8690CK



8690TN



8690FH Jaws Shown

HARD CABLE RATCHET CUTTERS

PART #	ACSR ACAR	EHS GUY STRAND	AIRCRAFT CABLE	WIRE ROPE STAINLESS STEEL	MILD STEEL ROD & BOLTS	SELF SUPPORTING TELEPHONE CABLE	LENGTH	REPLACEMENT CUTTER HEAD
8690FH	1.18"	--	--	--	--	1.18"	29-1/4"	8613FH
8690CK	--	.50"	--	--	.50"	--	28"	8613CK
8690TN	--	.63"	.63"	.63"	--	--	36"	8613TN

See pages 388 - 389 for repair parts.



8690CS



8790CS



8690FSK



8790FSK

SOFT CABLE RATCHET CUTTERS

PART #	CU / AL (POWER)	CU / AL COMMUNICATION	RUBBER & LEAD COVERED	LENGTH	WEIGHT	REPLACEMENT CUTTER HEAD
8690CS	3"	3"	3"	29-3/4"	1 lb.	8613CS
8690FSK	2"	2"	2"	27-1/2"	10 lbs.	8613FSK
8790CS	3"	3"	--	27-1/2"	15 lbs.	8713CS
8790FSK	2"	2"	--	27-1/2"	10.5 lbs.	8713FSK

See pages 388 - 389 for repair parts.

HAND-HELD RATCHETING SOFT CABLE CUTTERS

WARNING

These tools are NOT considered insulated. Do not attempt to cut energized conductors with any of these cutters.



SOFT CABLE RATCHET CUTTER

PART #	CAPACITY
RC400	400 MCM stranded copper/aluminum

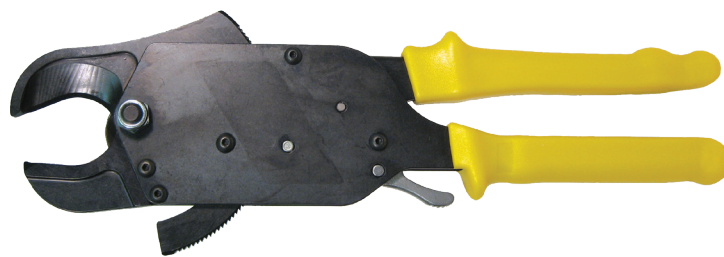

SOFT CABLE RATCHET CUTTER

PART #	CAPACITY
TE601	600 MCM stranded copper/aluminum

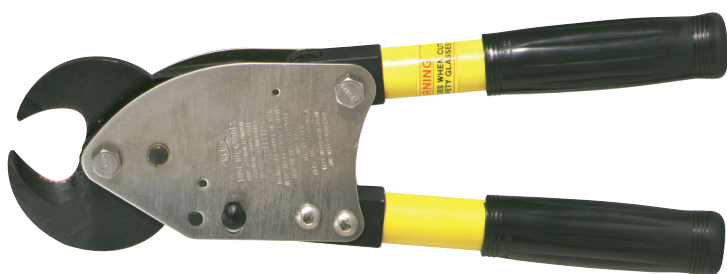

See page 387 for 6990FS repair parts.

SOFT CABLE RATCHET CUTTER

PART #	ALUMINUM /COPPER	OVERALL LENGTH
6990FS	795 MCM/500 MCM	14"



SOFT CABLE RATCHET CUTTER

PART #	CAPACITY
RC750	750 MCM stranded copper/aluminum



TE200

See page 399 for TE200 repair parts.

PRECISION CABLE CUTTERS

These tools provide cutting ease, minimum cable distortion and long life. The fiberglass handles meet ASTM F711.

PART #	LENGTH	CAPACITY
TE750	20"	750 MCM copper/aluminum
TE200	20"	2000 MCM copper/aluminum

HAND-HELD RATCHETING ACSR CABLE CUTTERS

WARNING

These tools are NOT considered insulated. Do not attempt to cut energized conductors with any of these cutters.



ACSR CUTTER

One hand ratchet cuts up to 600 MCM copper/aluminum and 336 MCM ACSR. Weighs 1.5 lbs. and is 10-1/4" long.

PART #	CAPACITY
63607	336 MCM ACSR



ACSR CUTTER

One hand ratchet cuts up to 336 ACSR, 500 MCM aluminum, 350 MCM copper. 10" overall length.

PART #	CAPACITY
TE336	336 single-strand ACSR



ACSR CUTTER

The replaceable cutting blades can easily cut through multi-strand 477 MCM ACSR. It also cuts up to 1-1/4" copper/aluminum, 1" solid copper and 1/2" guy wire, not for EHS. Weighs 3.2 lbs. and is 13-3/4" long.

PART #	CAPACITY
63800ACSR	477 MCM ACSR
63858	Replacement blade inserts



ACSR CUTTER

Ratchet-action design provides maximum leverage with minimum effort for heavy-duty use. Cuts steel and ACSR. Forged, heat-treated, shear-type blades, plus a 24" long steel handles with heavy vinyl grips for comfort and slip-resistance.

PART #	CAPACITY
63700	1113 MCM ACSR



ACSR CUTTER

The fiberglass handles incorporate a fast advance system that quickly close the blades around the wire.

PART #	CAPACITY
TE556	556 MCM multi-strand ACSR



POWER BLADE CABLE CUTTER

Attaches easily to almost any drill. The specially hardened, rounded blades cut up to 750 MCM hard drawn copper and 1,000 MCM aluminum and minimize cable distortion.

PART #
35-078



Interchangeable compression jaws

POWER BLADE CABLE CUTTER

Cuts up to 4/0 ACSR. It features a double speed pump and a 180° rotating head. Battery life indicator is built into the tool body. The tool kit comes with 2 each 9.6V Ni-MH batteries, charger and case. The cutting jaws can be replaced with crimping jaws.

PART #
B-54YMB1

INTERCHANGEABLE COMPRESSION JAW

PART #	NOSE	SEAT
CDD6	BG Nose	D3 Seat
CDD6-8	O Nose	D3 Seat



HTS-4040



HTS-4040-U

H-TAP REMOVAL DIE

Cleanly and accurately cuts through a wide range of tap connectors. The brass feeler gauges are set to the correct depth of the wire to be cut off from #6 through 4/0 ACSR.

PART #	DESCRIPTION
HTS-4040	Fits all WH-2 & WH-3 Kearney™ style compression heads
HTS-4040-U	Fits "U" type die compression heads

HANDHELD HYDRAULIC CUTTING TOOL



HANDHELD HYDRAULIC CUTTING TOOL

Cuts 1" Cu/Al cables, 5/8" EHS guy wire, and 5/8" ground rods. Features a double speed pump and a 180° rotating head.

PART #

HT-TC026Y



HANDHELD HYDRAULIC CUTTING TOOL

The HT-TC041 features an automatic safety valve to bypass the oil when the maximum pressure is reached. The flip-top head rotates 90°. 1-9/16" cutting capacity.

PART #

HT-TC041



HANDHELD HYDRAULIC CUTTING TOOL

2" opening cuts 2" ACSR, Cu / Al wire, 2" URD power cable, and 1" wire rope. Features 2-speed pump, a full flip-top 360° rotating head and a cutting force of 13.8 tons.

PART #

13HHC-B



HANDHELD HYDRAULIC CUTTING TOOL

The two stage hydraulic system advances the blades and the head rotates 327° to cut in almost any position. Designed to cut 2-3/16" Cu/Al conductors, 1-15/16" ACSR, 7/8" EHS guy wire, 13/16" steel rod, 1-1/2" copper rod.

PART #

HT-TC055

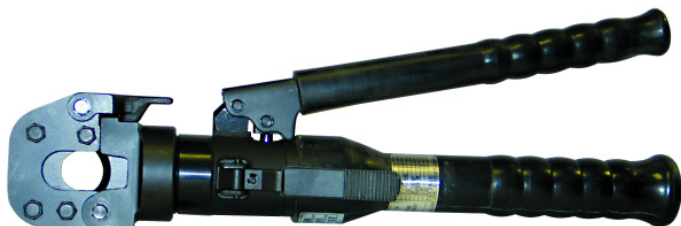

S-20



S-40B

DO NOT USE TO CUT EHS GUY WIRE

HANDHELD HYDRAULIC CUTTING TOOL

S-Series tools cut anything from guy wire* to anchor rod and most overhead and underground cables. These cutters are portable, lightweight, and made to last years under the toughest field conditions. The anvil style, center cut blades eliminate jamming problems common to shear style cutters, and the blades are easily replaced in the field. The tools are made of high grade steel and have rubber handle grips. All tools are black zinc oxide coated to help reduce corrosion. A flip-top latch opens the tool jaw to easily accept cables and wires. The head can be rotated up to 180° to facilitate easy wire positioning and operator leverage.

PART #	JAW OPENING	CAPACITY
S-20	3/4"	397 MCM ACSR
S-40B	1-1/2"	1510 MCM ACSR

BATTERY POWERD CABLE CUTTERS

The M18™ FORCE LOGIC™ cable cutter kits are powered by a Milwaukee® Powerstate™ brushless motor and M18™ Redlithium™ 2.0 Battery. Milwaukee One-Key is the first digital platform for tools and equipment. It utilizes a free to use smartphone app that allows users to sync wirelessly to their tools via Bluetooth. Once synced, the One-Key app enables customers to more efficiently customize, track and manage tools in their inventory.



M18™ FORCE LOGIC™ CABLE CUTTER KIT WITH 477 ACSR JAWS

This open jaw, fully balanced in-line tool delivers unmatched control and accuracy. Featuring patented anti-spreading jaws, this compact tool powers through 477 Hen ACSR in seconds. Milwaukee delivers on its Heavy Duty promise making up to 1,000 cuts on a single set of blades. With the M18™ Redlithium™ Battery this tool can make over 280 cuts on a M18™ 2.0 Battery, making it the most productive tool of its kind. The kit includes (1) M18™ 2.0 Redlithium™ battery, 120 VAC charger and bucket bag.

PART #	CAPACITY	BATTERY	CHARGER	WEIGHT
2672-21S	477 ACSR	18 V Lithium-ion	AC/DC	4.65 lbs.



M18™ FORCE LOGIC™ CABLE CUTTER KIT WITH 750 MCM CU JAWS

This open jaw, fully balanced in-line tool allows you to cut effortlessly in the tightest panels without looping. Featuring the best power to size ratio, this compact tool powers through 750 MCM copper or 1000 MCM aluminum 2X faster than the leading competitor. The kit includes (1) M18™ 2.0 Redlithium™ battery, multi-voltage charger and carrying case.

PART #	CAPACITY	BATTERY	CHARGER	WEIGHT
2672-21	750 MCM Cu / 1000 Al	18 V Lithium-ion	120 VAC	4.65 lbs.

BATTERY POWERD CABLE CUTTERS

The M18™ FORCE LOGIC™ cable cutter kits are powered by a Milwaukee® Powerstate™ brushless motor and M18™ REDLITHIUM™ 2.0 Battery. Milwaukee One-Key is the first digital platform for tools and equipment. It utilizes a free to use smartphone app that allows users to sync wirelessly to their tools via Bluetooth. Once synced, the One-Key app enables customers to more efficiently customize, track and manage tools in their inventory.



M18™ FORCE LOGIC™ 3" UNDERGROUND CABLE CUTTER

Engineered to deliver the best cutting experience in a trench. Linemen can now scoop the cable into the open jaw with ease, maintaining balance when lining up to cut. Once aligned, the M18™ Force Logic™ 3" underground cable cutter is the fastest cutter in its class, making installation and wrecking of up to 1500mcm copper 15kv cable a breeze. The kit includes: (1) M18™ lithium-ion 120 VAC wall charger, a M18™ Redlithium™ XC 5.0 Extended capacity battery pack, carabineer and utility bag.

PART #	CAPACITY	BATTERY	CHARGER	WEIGHT
2776-21	1500 MCM Copper	18 V Lithium-ion	120 VAC	15.7 lbs.



M18™ FORCE LOGIC™ 1590 ACSR CABLE CUTTER

A patent pending jaw design enables opening with just two fingers, enhancing alignment while delivering easiest operation with Class 3 Gloves. The wire automatically closes the jaw, providing hands-free jaw closure and the easiest mid-span cuts. Fully balanced, only 11.75 lbs. and the fastest transmission cutter, the M18™ FORCE LOGIC™ 1590 ACSR Cutter delivers the best control while enhancing linemen's productivity and reducing fatigue. Kit includes: (1) M18™ lithium-ion AC/DC wall & vehicle charger, (1) M18™ Redlithium™ XC5.0 extended capacity battery pack, carabineer and utility bag.

PART #	CAPACITY	BATTERY	CHARGER	WEIGHT
2777-21	1590 ACSR	18 V Lithium-ion	120 VAC	11.7 lbs.

CABLE CUTTERS



49-16-2772



49-16-2773



48-59-1801



48-59-1810



48-11-1820



48-11-1850

ACCESSORIES

PART #	DESCRIPTION
49-16-2772	M18™ Cu/Al jaw
49-16-2773	M18™ ACSR jaw
48-59-1801	M18™ Lithium-ion battery charger
48-59-1810	M18™ / M12™ vehicle charger
48-11-1820	M18™ Redlithium™ 2.0 compact battery pack
48-11-1850	M18™ Redlithium™ XC5.0 extended capacity battery pack

18V BATTERY POWERED 1.29" ACSR CUTTER

The PATCUT129-LI incorporates a specialized latch-style cutting head that allows interference-free closure for mid-span cuts. The cutter head rotates 180°. Kit is supplied with a durable high impact formed carrying case, battery charger, two 18 V Lithium-ion Makita batteries and tool retention lanyard.

PART #	CAPACITY	BATTERY	CHARGER	WEIGHT
PATCUT129LI	1113 ACSR	18 V Li-ion (3Ah)	120 VAC	10.2 lbs.
PATCUT129L5	1113 ACSR	18 V Li-ion (5Ah)	120 VAC	10.2 lbs.
PATCUT129L5DC	1113 ACSR	18 V Li-ion (5Ah)	12 VDC	10.2 lbs.



18V BATTERY POWERED 2" ACSR CUTTER

The PATCUT2156-LI cutting tool is a compact, fast and versatile tool capable of cutting a variety of cable types and materials. The ergonomic design allows one hand operation so that the other is free to manipulate the conductor into position. Kit supplied with a durable high impact formed carrying case to hold the tool, battery charger, (2) 18 V Lithium-ion Makita batteries and tool retention lanyard.

PART #	CAPACITY	BATTERY	CHARGER	WEIGHT
PATCUT129LI	2156 ACSR	18 V Li-ion (3Ah)	120 VAC	15.5 lbs.
PATCUT129L5	2156 ACSR	18 V Li-ion (5Ah)	120 VAC	15.5 lbs.
PATCUT129L5DC	2156 ACSR	18 V Li-ion (5Ah)	12 VDC	15.5 lbs.



18V BATTERY POWERED 2.45" CU/AL CABLE CUTTER

The PATCUT245-LI incorporates a specialized latch style cutting head that allows interference-free closure for mid-span cuts. The cutter head rotates 180° to allow users to get into tight areas easier. Kit supplied with a durable high impact formed carrying case to hold the tool, battery charger, (2) 18 V Lithium-ion Makita batteries and tool retention lanyard.

PART #	CAPACITY	BATTERY	CHARGER	WEIGHT
PATCUT245LI	2.45" Cu/Al	18 V Li-ion (3Ah)	120 VAC	13.7 lbs.
PATCUT245L5	2.45" Cu/Al	18 V Li-ion (5Ah)	120 VAC	13.7 lbs.
PATCUT245L5DC	2.45" Cu/Al	18 V Li-ion (5Ah)	12 VDC	13.7 lbs.



CABLE CUTTERS



18V BATTERY OPERATED 4" CU/AL CUTTER

Specifically designed to accommodate large copper and aluminum cables up to 4" diameter, typically seen in underground environments for power and communication applications. A multi-position assist handle is included to help with balance, comfort, and operator control. Kit includes: (2) 18 V Lithium-ion Makita batteries, charger, lanyard, polymer carrying case.

PART #	CAPACITY	BATTERY	CHARGER	WEIGHT
PATCUT245LI	4" Cu/Al	18 V Lithium-ion (3Ah)	120 VAC	20.3 lbs.
PATCUT245L5	4" Cu/Al	18 V Lithium-ion (5Ah)	120 VAC	20.3 lbs.
PATCUT245L5DC	4" Cu/Al	18 V Lithium-ion (5Ah)	12 VDC	20.3 lbs.



BAT18VLI



BAT18V5AHLI



PATCHGRLI

ACCESSORIES

PART #	DESCRIPTION
BAT18VLI	18 Volt Lithium-ion (3Ah) battery
BAT18V5AHLI	18 Volt Lithium-ion (5Ah) battery
PATCHGRLI	120 VAC charger
PATCHGR-LIDC	12/24 VDC charger
PT10074020	Wrist strap
W28K	Cutter dies: cuts 4-4/0 Cu, Al, ACSR

CABLE CUTTERS

These inline cordless hydraulic cutting tools can be operated with one hand and balanced for greater control. The head rotates 180° for ease of operation in confined spaces. They are fitted with a maximum pressure valve and are extremely quiet, minimal vibration.

The New Lithium-ion 18 V (2Ah) high power battery is equipped with led indicators to show the remaining battery life.



B-TC250BSA



B35M-TC025A

18V BATTERY POWERED INLINE CUTTING TOOLS

Kit includes: Tool, (2) 18 V Lithium-ion Metabo batteries, strap, AC charger, and case.

Also available with Makita batteries, specify when ordering.

PART #	CAPACITY	BATTERY	CHARGER	WEIGHT
B-TC250BSA	1" Cu/Al	18 V Lithium-ion (2Ah)	120 VAC	7.4 lbs.
B35M-TC025A	1" ACSR	18 V Lithium-ion (2Ah)	120 VAC	6.82 lbs.

CABLE CUTTERS

Next generation of 18.0 V cordless hydraulic cutting tool specifically designed cut copper, aluminum, ACSR, steel ropes. The blades are manufactured from high strength special steel, heat treated to ensure a long service life. New Lithium-ion 18 V (4Ah) batteries offer a higher capacity than 14.4 V 3Ah, while greater cutting speed and cutting force result from a revitalized hydraulic system with double speed action. The battery is equipped with led indicators that indicate the remaining battery life.



B-TC250YA



B-TC450A



B-TC500A



B-TC500YA



B-TC550A



B-TC650A

18V BATTERY OPERATED CUTTING TOOLS

Kit includes tool, (2) 18 V Lithium-ion Metabo batteries, strap, AC charger, and case.

Also available with Makita batteries, specify when ordering.

PART #	CAPACITY	BATTERY	CHARGER	WEIGHT
B-TC250YA	1" ACSR	18 V (4Ah)	120 VAC	10.5 lbs.
B-TC450A	1-3/4" ACSR	18 V (4Ah)	120 VAC	14.7 lbs.
B-TC500A	2" Cu/Al	18 V (4Ah)	120 VAC	12.7 lbs.
B-TC500YA	2" ACSR	18 V (4Ah)	120 VAC	12.7 lbs.
B-TC550A	2-3/16" ACSR	18 V (4Ah)	120 VAC	19.6 lbs.
B-TC650A	2-9/16" Cu/Al	18 V (4Ah)	120 VAC	14.1 lbs.

CABLE CUTTERS

Next generation of 18.0 V cordless hydraulic cutting tool specifically designed to cut copper, aluminum and telecommunication cables. The blades are manufactured from high strength special steel, heat treated to ensure a long service life. New Lithium-ion 18 V (4Ah) batteries offer a higher capacity than 14.4 V (3Ah), while greater cutting speed and cutting force result from a revitalized hydraulic system with double speed action. The battery is equipped with led indicators that indicate the remaining battery life.



B-TC650-SCA



B-TC950A

18V BATTERY POWERED CUTTING TOOLS

Kit includes basic tool with shoulder strap, (2) 18 V Lithium-ion Metabo batteries, AC charger, USB cable, metal carrying case.
Also available with Makita batteries, specify when ordering.

PART #	CAPACITY	BATTERY	CHARGER	WEIGHT
B-TC650-SCA	2-9/16" Cu/Al	18 V (4Ah)	120 VAC	16.9 lbs.
B-TC950A	3-3/4" Cu/Al	18 V (4Ah)	120 VAC	17.1 lbs.



ASC30-36



CB1840L



CINV12-110IC

ACCESSORIES

PART #	DESCRIPTION
ASC30-36	AC charger
CB1820L	18 Volt Lithium-ion (2.0Ah) battery
CB1840L	18 Volt Lithium-ion (4.0Ah) battery
CINV12-110IC	12 Volt car power inverter

CABLE CUTTERS

Compact in-line tool is lightweight and easy to control. They will automatically retract when the cutting cycle is complete. The scissor style cutting head is designed to cut soft metals such as Copper & Aluminum. The cutting blade will automatically retract when the cutting cycle is complete. Equipped with Bluetooth™ Communication enabled via the Greenlee Gator Eye app. Features LED display screen communicating pressure and battery levels as well as tool diagnostics with real-time tool feedback.



ES32LX11



ESC35LX11

ES32L IN LINE CABLE CUTTER

Kit Includes: tool charger, (2) Makita® 18 V Lithium-ion batteries & case.

PART #	CAPACITY	BATTERY	CHARGER	WEIGHT
ES32LX11	500 kcmil Cu/AL	18 V (4Ah)	120 VAC	5 lbs.
ES32LX12	500 kcmil Cu/AL	18 V (4Ah)	12 VDC	5 lbs.
ESC35LX11	1000 kcmil Cu/AL	18 V (4Ah)	120 VAC	5 lbs.
ESC35LX12	1000 kcmil Cu/AL	18 V (4Ah)	12 VDC	5 lbs.

REPLACEMENT BLADES

PART #	DESCRIPTION
12092	ES32L movable blade
12093	ES32L fixed blade

CABLE CUTTERS

Compact in-line tool is lightweight and easy to control. They will automatically retract when the cutting cycle is complete. The cutting blade will automatically retract when the cutting cycle is complete. Equipped with Bluetooth™ Communication enabled via the Greenlee Gator Eye app. Features LED display screen communicating pressure and battery levels as well as tool diagnostics with real-time tool feedback.



ES20LX11



ESG25LX11



ESG45LX11

ES20LX IN LINE CABLE CUTTER

Kit Includes: tool charger, (2) Makita® 18 V Lithium-ion batteries & case.

PART #	CAPACITY	BATTERY	CHARGER	WEIGHT
ES20LX11	336.4 ACSR, 3/8" guy wire	18 V (4Ah)	120 VAC	4.6 lbs.
ES20LX12	336.4 ACSR, 3/8" guy wire	18 V (4Ah)	12 VDC	4.6 lbs.
ESG25LX11	636 ACSR, 5/8" guy wire	18 V (4Ah)	120 VAC	4.6 lbs.
ESG25LX12	636 ACSR, 5/8" guy wire	18 V (4Ah)	12 VDC	4.6 lbs.
ESG45LX11	1590 ACSR, 5/8" guy wire	18 V (4Ah)	120 VAC	4.6 lbs.
ESG45LX12	1590 ACSR, 5/8" guy wire	18 V (4Ah)	12 VDC	4.6 lbs.

REPLACEMENT BLADES

PART #	DESCRIPTION
ES20E	ES20LX replacement blade kit
76807	ESG25LX replacement blade kit

CABLE CUTTERS

Designed specifically to cut copper and aluminum cables communication, which is enabled via the greenlee gator eye app. The 18 V Lithium-ion (Li-ion) battery provides 70% more cycles per charge.



ESG50LX GUILLOTINE HEAD CABLE CUTTER

PART #	CAPACITY	BATTERY	CHARGER	WEIGHT
ESG50LX11	2" Cu/Al	18 V (4Ah)	120 VAC	9.8 lbs.
ESG50LX12	2" Cu/Al	18 V (4Ah)	12 VDC	9.8 lbs.
ESG50LXB	2" Cu/Al	18 V (4Ah)	Bare tool	9.8 lbs.



ESC85LX SCISSOR HEAD CABLE CUTTER

PART #	CAPACITY	BATTERY	CHARGER	WEIGHT
ESC85LX11	3-3/8" Cu/Al	18 V (4Ah)	120 VAC	22 lbs.
ESC85LX12	3-3/8" Cu/Al	18 V (4Ah)	12 VDC	22 lbs.
ESC85LXB	3-3/8" Cu/Al	18 V (4Ah)	Bare tool	22 lbs.



ESG105LX GUILLOTINE HEAD CABLE CUTTER

PART #	CAPACITY	BATTERY	CHARGER	WEIGHT
ESG105LX11	4" Cu/Al	18 V (4Ah)	120 VAC	22 lbs.
ESG105LX12	4" Cu/Al	18 V (4Ah)	12 VDC	22 lbs.
ESG105LXB	4" Cu/Al	18 V (4Ah)	Bare tool	22 lbs.



ESC105LX SCISSOR HEAD CABLE CUTTER

PART #	CAPACITY	BATTERY	CHARGER	WEIGHT
ESC105LX11	4" Cu/Al	18 V (4Ah)	120 VAC	22 lbs.
ESC105LX12	4" Cu/Al	18 V (4Ah)	12 VDC	22 lbs.
ESC105LXB	4" Cu/Al	18 V (4Ah)	Bare tool	22 lbs.

CABLE CUTTERS



05167



52178



52180

ACCESSORIES

High capacity Makita® battery platform with active battery monitoring system improves your battery supply.

PART #	DESCRIPTION
05167	18 Volt Lithium-ion (4.0Ah)
52178	120 Volt Lithium-ion battery charger
52180	12 Volt Lithium-ion battery charger

CABLE CUTTERS



STREAMLINE CUTTING TOOL

The SL-S20 was designed to cut the toughest steel used in construction today. It can replace an entire tool kit, including several sizes of conventional bolt cutters, hacksaws, acetylene torches and cable cutters. Kit includes: battery powered tool, carrying case, charger, (2) Lithium-ion batteries and carrying strap.

PART #	CAPACITY	BATTERY	CHARGER	WEIGHT
SL-S20	477 ACSR	14.4 V (4Ah)	120 VAC	7.7 lbs.



REC-630Y



REC-634YC

C-JAW CUTTING TOOL

PART #	CAPACITY	BATTERY	CHARGER	WEIGHT
REC-630Y	336 ACSR	14.4 V (4Ah)	120 VAC	7.7 lbs.
REC-634YC	800 MCM Cu / 1.4" O.D. Al	14.4 V (4Ah)	120 VAC	9.9 lbs.



REC-660YC



REC-685YC

SCISSOR-TYPE CUTTING TOOL

PART #	CAPACITY	BATTERY	CHARGER	WEIGHT
REC-660YC	500 MCM Cu/Al	14.4 V (4Ah)	120 VAC	10.2 lbs.
REC-685YC	1000 MCM Cu/Al	14.4 V (4Ah)	120 VAC	13.9 lbs.



REMOTE HYDRAULIC CUTTING HEAD

Complete with quick automatic coupler for connection to a hydraulic pump with a working pressure of 10,000 PSI max. 1-9/16" cutting capacity. ACSR, 5/8" EHS guy wire, 11/16" steel rod, 1-1/8" copper rod, and 1-9/16" aluminum rod.

PART #
TC04



REMOTE HYDRAULIC CUTTING HEAD

Tool is designed for expanded cutting capabilities up to 2" diameter. Accepts 2" ACSR, 2" Cu / Al cable, wire rope, 2" URD power cable, and 1" wire rope.

PART #
13HCR-C

MANUAL COMPRESSION TOOLS



CRIMPING TOOL

This one hand ratcheting crimper is designed to install 5/8" Insulink and Linkit service entrance connectors with a single crimp. Conductor sizes # 10 through 1/0.

PART #

OH25



CRIMPING TOOL

With nest and indenter dies, this ratcheting tool will install 5/8" Insulink and Linkit service entrance connectors. With X-Dies, additional splices, taps and terminals can be installed.

PART #

OUR840



FIXED DIE COMPRESSION TOOL

The single 5/8" die is used to crimp bare and insulated Serv-ens Connectors, triplex sleeves and URD connectors.

PART #

OS50



DIELESS COMPRESSION TOOL

Does not require interchangeable crimping dies. Crimping head rotates 350° to get into tight locations. Two-speed pump provides rapid crimping cycle time. Lightweight and strong fiberglass handles. Comes with a molded carrying case. Capacity: Copper # 4 - 1000 MCM, Aluminum # 6 - 1000 MCM.

PART #

HK12ID



MD6 TYPE TOOLS

Installs a full range of connectors, taps, splices & terminals from #14 through 4/0 for Full-Tension and Non-Tension applications. The D3 groove serves as a die seat to accept W-type dies.

PART #	DIE GROOVE	NOSE DIE	HANDLES
MD6	D3	BG (5/8")	Wood
MD6-8	D3	O	Wood
MD6-4	D3	BG (5/8")	Fiberglass
MD7	D3	BG (5/8")	Polymer
MD7-8	D3	O	Polymer



XPJ COMPRESSION TOOL

This tool has three compression grooves for use with oval sleeves. Connector sizes #2, #4, #6 (X,P and J) Cable sizes 3/16", 3/8", 5/32".

PART #

TE246



We stock virtually every W-type die.

MANUAL COMPRESSION TOOLS



12 TON COMPRESSION TOOLS

The Y35 incorporates a C-shaped head with a 1" jaw opening, 180° rotating head, and a rapid ram advance system. These tools accept U-type dies and are commonly used on conductor sizes from #6 through 556.5 ACSR.

PART #	DESCRIPTION
Y35	Hand compression tool



12 TON COMPRESSION TOOLS

The 131LN Hydraulic C-shaped head rotates 180°, has a jaw opening of 1.65", and a two-speed pump. These tools accept U-type dies and are commonly used on conductor sizes from #6 through 750 MCM.

PART #	DESCRIPTION
HT131LN-C	Hand compression tool



DIELESS COMPRESSION TOOLS

These tools utilizes four indenters to make the crimp. The compact, flip-top head rotates a full 360°. The two-speed pump rapidly advances the ram. Crimps copper connectors from #4 to 750 MCM, Aluminum #4 to 500 MCM.

PART #	DESCRIPTION
HK06FT	Hand compression tool

BATTERY POWERED COMPRESSION TOOLS

Milwaukee® Crimpers feature a fully enclosed high speed hydraulic pump, POWERSTATE™ Brushless Motor, REDLINK™ Electronics and Redlithium™ Batteries delivering Ultimate Reliability in the toughest conditions and up to 4x longer life. Milwaukee® 6T Utility Crimpers deliver Confidence for any Power Emergency. Featuring Milwaukee® ONE KEY™ Technology, Milwaukee® 6T Crimpers enable you to store real time crimp data, generate professional reports, view historical tool performance data and sync it all wirelessly to the cloud for easy access.



M18™ FORCE LOGIC™ 6 TON UTILITY CRIMPERS

Kit includes: Tool, M18™ Lithium-ion AC charger, (2) M18™ Redlithium™ (2.0Ah) compact battery packs, (1) M18™ 6T crimping jaw, carabineer, and utility bag.

PART #	HEAD	BATTERY	CHARGER	WEIGHT
2678-22BG	D3 and Fixed BG	18 V Li-ion (2.0Ah)	120 VAC	4.6 lbs.
2678-22O	D3 and Fixed O	18 V Li-ion (2.0Ah)	120 VAC	4.6 lbs.
2678-22	Snub Nose D3	18 V Li-ion (2.0Ah)	120 VAC	4.6 lbs.
2678-22K	Kearney™	18 V Li-ion (2.0Ah)	120 VAC	4.6 lbs.



49-16-00D3



49-16-00D3



49-16-KEAR



49-16-BGD3



49-16-2772



49-16-2773

6 TON UTILITY CRIMPER JAWS

Easily interchangeable on any 2678-20 tool, clear die / groove markings and accepts all industry standard "W" style dies.

PART #	DESCRIPTION
49-16-00D3	6T Fixed O crimping jaw
49-16-00D3	6T Snub nose crimping jaw
49-16-KEAR	6T Kearney™ crimping jaw
49-16-BGD3	6T Fxed BG crimping jaw
49-16-2772	Cable cutting jaw, 750 MCM capacity
49-16-2773	ACSR cutting jaw, 477 capacity

BATTERY POWERED COMPRESSION TOOLS

Milwaukee® Crimpers feature a fully enclosed high speed hydraulic pump, POWERSTATE™ Brushless Motor, REDLINK™ Electronics and Redlithium™ batteries delivering longer life and Ultimate Reliability. Featuring Milwaukee® ONE KEY™ Technology, the first digital platform for tools and equipment. It utilizes a free to use smartphone app that allows users to sync wirelessly to their tools via Bluetooth. Once synced, the One-Key app enables customers to efficiently customize, track and manage tools in their inventory.



M18™ FORCE LOGIC™ 12 TON CRIMPER

Kit includes: M18™ Lithium-ion AC/DC wall & vehicle charger, (1) M18™ Redlithium™ (2.0Ah) compact battery pack, (1) M18™ Redlithium™ XC (5.0Ah) extended capacity battery pack, carabineer and overhead utility bag.

PART #	HEAD	BATTERY	CHARGER	WEIGHT
2778-22	Y-750	18 V Lithium-ion	120 VAC	15 lbs.



48-11-1820



48-11-1850

ACCESSORIES

PART #	VOLTAGE
48-11-1820	M18™ Redlithium™ 2.0 compact battery pack
48-11-1850	M18™ Redlithium™ XC5.0 extended capacity battery pack
48-59-1801	M18™ Lithium-ion battery charger
48-59-1810	M18™ / M12™ vehicle charger



6 TON IN-LINE CRIMPING TOOL

Interchangeable scissor action crimping and cutting jaws, safety trigger lock and locking jaw tabs, LED worklight 3.0Ah and 5.0Ah versions available.

Includes (2) batteries, charger, tool bag, and tool lanyard.

PART #	HEAD	BATTERY	CHARGER	WEIGHT
PATMD6LW	BG + D3	18 Volt Li-ion (3Ah)	120 VAC	6.7 lbs.
PATMD68LW	O + D3	18 Volt Li-ion (3Ah)	120 VAC	6.7 lbs.
PATMD66LW	D3 Only	18 Volt Li-ion (3Ah)	120 VAC	6.7 lbs.
PATMD6LW5	BG + D3	18 Volt Li-ion (5Ah)	120 VAC	6.7 lbs.
PATMD66LW5	O + D3	18 Volt Li-ion (5Ah)	120 VAC	6.7 lbs.
PATMD6-K-L5	D3 Only	18 Volt Li-ion (5Ah)	120 VAC	6.7 lbs.

* Add DC suffix to PART # for 12 VDC charger in place of AC version.



PATMD6LWJAW



PATMD66LWJAW



PATMD68LWJAW



PATMDCUTLWJAW

INTERCHANGEABLE JAW ASSEMBLIES

PART #	DESCRIPTION
PATMD6LWJAW	BG and D3 grooves
PATMD66LWJAW	D3 only (snub-nose)
PATMD68LWJAW	O and D3 grooves
PATMDCUTLWJAW	Cutter jaw set, includes ACSR blades

4-POINT® C-HEAD DIELESS 6 TON CRIMPING TOOL

Range taking capabilities. 360° head rotation. Ergonomically balanced.
Kit Includes: (2) 18 V Lithium-ion Makita batteries, charger, and carrying case.

PART #	HEAD	BATTERY	CHARGER	WEIGHT
PAT4PC834LI	Dieless	18 V Li-ion (3Ah)	120 VAC	13.0 lbs.
PAT4PC834L5	Dieless	18 V Li-ion (5Ah)	120 VAC	13.0 lbs.
PAT4PC834L5DC	Dieless	18 V Li-ion (5Ah)	12 VDC	13.0 lbs.



4-POINT® DIELESS 6 TON CRIMPING TOOL

Range taking capabilities. 360° head rotation. Mechanical ram release.
Includes: (2) 18 V Lithium-ion Makita batteries, charger, and carrying case.

PART #	HEAD	BATTERY	CHARGER	WEIGHT
PAT81KFTLI	Dieless	18 V Li-ion (3Ah)	120 VAC	13.2 lbs.
PAT81KFTL5	Dieless	18 V Li-ion (5Ah)	120 VAC	13.2 lbs.
PAT81KFTL5DC	Dieless	18 V Li-ion (5Ah)	12 VDC	13.2 lbs.



11 TON LATCH HEAD CRIMPING TOOL

Dieless system features, range taking capabilities, 355° head rotation and is ergonomically balanced. Kit includes: (2) 18 V Lithium-ion Makita batteries, charger and polymer carrying case.

PART #	HEAD	BATTERY	CHARGER	WEIGHT
PAT644LI	Dieless	18 V Li-ion (3Ah)	120 VAC	16.3 lbs.
PAT644L5	Dieless	18 V Li-ion (5Ah)	120 VAC	16.3 lbs.
PAT644L5DC	Dieless	18 V Li-ion (5Ah)	12 VDC	16.3 lbs.





12 TON C-HEAD CRIMPING TOOL

1.65" jaw opening. Used with U dies. 355° head rotation.

Kit includes: (2) 18 V Lithium-ion Makita batteries, charger, and carrying case.

PART #	HEAD	BATTERY	CHARGER	WEIGHT
PAT750LI	Y-750 style	18 V Li-ion (3Ah)	120 VAC	13.2 lbs.
PAT750L5	Y-750 style	18 V Li-ion (5Ah)	120 VAC	13.2 lbs.
PAT750L5DC	Y-750 style	18 V Li-ion (5Ah)	12 VDC	13.2 lbs.



15-TON LIGHT WEIGHT LATCH HEAD

Used with P dies, U dies with PUADP-1 adapter (sold separately).

Light weight, Latch-head 355° head rotation. Ergonomically balanced.

Kit includes: (2) 18 V Lithium-ion Makita batteries, charger, and carrying case.

PART #	HEAD	BATTERY	CHARGER	WEIGHT
PAT46LWLI	Y-46 style	18 V Li-ion (3Ah)	120 VAC	16.8 lbs.
PAT46LWL5	Y-46 style	18 V Li-ion (5Ah)	120 VAC	16.8 lbs.
PAT46LWL5DC	Y-46 style	18 V Li-ion (5Ah)	12 VDC	16.8 lbs.



15-TON LIGHT WEIGHT LATCH HEAD

2" jaw opening. Used with P dies, U dies with PUADP-1 adapter (sold separately). Light weight, scoop style C-head with 355° head rotation.

Overmolded handle, ergonomic handle Ergonomically balanced.

Kit includes: (2) 18 V Lithium-ion Makita batteries, charger, and carrying case.

PART #	HEAD	BATTERY	CHARGER	WEIGHT
PAT46LWSLI	Y-46 style	18 V Li-ion (3Ah)	120 VAC	19.1 lbs.
PAT46LWSL5	Y-46 style	18 V Li-ion (5Ah)	120 VAC	19.1 lbs.
PAT46LWSLIDC	Y-46 style	18 V Li-ion (5Ah)	12 VDC	19.1 lbs.

BATTERY POWERED COMPRESSION TOOLS



PATCHGR LI



PUADP-1



BAT18V5AHLI



BAT18VLI

ACCESSORIES

PART #	DESCRIPTION
BAT18VLI	18 Volt Lithium-ion (3Ah) battery
BAT18V5AHLI	18 Volt Lithium-ion (5Ah) battery
PATCHGR LI	120 VAC charger
PATCHGR-LIDC	12/24 VDC charger
PATMD6JC	Jaw covers for PATMD6 & PATMD6-8 versions
PATMD66JC	Jaw covers for PATMD6-6 snub-nose versions
PATMD6KJC	Jaw covers for PATMD6K snub-nose versions
PT10074020	Wrist strap
PUADP-1	Stainless steel U die adapter
W28K	Cutter dies: cuts 4-4/0 Cu, Al, ACSR



18.0 V CORDLESS HYDRAULIC CRIMPING TOOL

Easily operated with one hand this tool is ideal for crimping #22 - #6 insulated terminals. Head rotates 340°. Additional die inserts available. Kit includes: Tool, (2) 18 V Lithium-ion Metabo batteries, strap, AC charger, and case.

PART #	HEAD	BATTERY	CHARGER	WEIGHT
B15MA	Terminal connector	Li-ion 18 V (2Ah)	120 VAC	3.8 lbs.

Also available with Makita batteries, specify when ordering.



6 TON CORDLESS HYDRAULIC CRIMPING TOOL

Ideal for overhead lines and residential service applications. 180° rotating head. Kit includes: Tool, (2) 18 V Lithium-ion Metabo batteries, AC charger and vinyl bag.

PART #	HEAD	BATTERY	CHARGER	WEIGHT
B54M-D6A	D3 + BG	Li-ion 18 V (2Ah)	120 VAC	6.5 lbs.
B54M-D6-8A	D3 + O	Li-ion 18 V (2Ah)	120 VAC	6.5 lbs.
B54M-KA	Kearney™	Li-ion 18 V (2Ah)	120 VAC	6.5 lbs.

Also available with Makita batteries, specify when ordering.



CMB-1



CMB-2



CMB-3

OPTIONAL CUTTING JAWS FOR USE WITH B54M

All cutting jaws delivered into sturdy canvas bag to secure and facilitate transport and storage.

PART #	DESCRIPTION
CMB-1	Cuts one-time disposable lock hasps, 4 AWG Alumoweld, ACSR 4/0
CMB-2	Cuts # 8 Copperweld, 4/0 Cu., 336 MCM aluminium, 477 MCM ACSR (Strand 26/7)
CMB-3	Cuts guy wire up to 3/8"

BATTERY POWERED COMPRESSION TOOLS

These tools have an OLED display which provides essential real time tool operating information including: crimping pressure and force, battery power, tool identification, LED work light state, and number of crimp cycles. Crimping cycle data (up to 200,000 crimps) is automatically stored on a memory card and can be transferred to PC by USB interface.



B1350-CA



B1350L-CA

14.6 TON CORDLESS HYDRAULIC CRIMPING TOOL

Featuring a pistol grip design, crimping head can rotate 180° and accepts 12 Ton U-Dies. Kit includes: Tool, (2) 18 V Lithium-ion Metabo batteries, shoulder strap, AC charger, and case.

PART #	HEAD	BATTERY	CHARGER	WEIGHT
B1350-CA	Y-35 Style	18 V (4Ah)	120 VAC	14.3 lbs.
B1350L-CA	Y-750 Style	18 V (4Ah)	120 VAC	17.8 lbs.

Also available with Makita batteries, specify when ordering.



B1300-C



B1300L-C

14.6 TON CORDLESS HYDRAULIC CRIMPING TOOL

Featuring a suitcase style design, crimping head can rotate 180° and accepts 12 Ton U-Dies. Kit includes: Tool, (2) 18 V Lithium-ion Metabo batteries, shoulder strap, AC charger, and case.

PART #	HEAD	BATTERY	CHARGER	WEIGHT
B1300-C	Y-35 Style	18 V (4Ah)	120 VAC	14.3 lbs.
B1300L-C	Y-750 Style	18 V (4Ah)	120 VAC	17.6 lbs.

Also available with Makita batteries, specify when ordering.

BATTERY POWERED COMPRESSION TOOLS

These tools have an OLED display which provides essential real time tool operating information including: crimping pressure and force, battery power, tool identification, LED work light state, and number of crimp cycles. Crimping cycle data (up to 200,000 crimps) is automatically stored on a memory card and can be transferred to PC by USB interface.



U-DIE ADAPTER

PART #
PUADP-1



15 TON CORDLESS HYDRAULIC CRIMPING TOOL

This tool will accept directly all 15 Ton "P" dies and with the use of the PUADP-1 adapter it will accept all 12 Ton "U" dies. Kit includes: Tool, (2) 18 V Lithium-ion Metabo batteries, shoulder strap, AC charger, and case.

PART #	HEAD	BATTERY	CHARGER	WEIGHT
B1500A	Y46 Style	18 V (4Ah)	120 VAC	21.3 lbs.

Also available with Makita batteries, specify when ordering.



ASC30-36



CB1840L



CINV12-110IC

ACCESSORIES

PART #	DESCRIPTION
ASC30-36	AC charger
CB1820L	18 Volt Lithium-ion (2.0Ah) battery
CB1840L	18 Volt Lithium-ion (4.0Ah) battery
CINV12-110IC	12 Volt car power inverter

BATTERY POWERED COMPRESSION TOOLS

The new design of Crimping and Cutting Tools featuring Intelli-CRIMP® technology, Gator Eye® Diagnostic System, and Blue Tooth® Communication. The new Design incorporates real-time communication of details associated with the tool, including battery charge, pressure level, and cycle information.

EK425LX 6 TON IN-LINE CRIMPER

Kit includes: tool, two batteries, charger, and case.

PART #	HEAD	BATTERY	CHARGER	WEIGHT
EK425LXD011	D3 and Fixed O	18 V (4Ah)	120 VAC	6.6 lbs.
EK425LXD012	D3 and Fixed O	18 V (4Ah)	12 VDC	6.6 lbs.
EK425LXDBG11	D3 and Fixed BG	18 V (4Ah)	120 VAC	6.6 lbs.
EK425LXDBG12	D3 and Fixed BG	18 V (4Ah)	12 VDC	6.6 lbs.
EK425LXK11	Kearney™ style	18 V (4Ah)	120 VAC	6.6 lbs.
EK425LXK12	Kearney™ style	18 V (4Ah)	12 VDC	6.6 lbs.
EK425LXD11	Snub nose D3	18 V (4Ah)	120 VAC	6.6 lbs.
EK425LXD12	Snub nose D3	18 V (4Ah)	12 VDC	6.6 lbs.



CJD30

CJD3BG

CJK

CJD3

CJB

CJXPJ

OPTIONAL CRIMPING JAWS & CUTTERS

PART #	DESCRIPTION
CJD30	Crimping jaw unit - D3 and O die grooves
CJD3BG	Crimping jaw unit - D3 and BG die grooves
CJK	Crimping jaw unit - Kearney™ dies
CJD3	Crimping jaw unit Snub Nose D3
CJB	Cutting head. cuts disposable locks, #4 Alumoweld up to 1/0 ACSR
CJXPJ	Crimping jaw with Nicopress X, P, & J die grooves

BATTERY POWERED COMPRESSION TOOLS

Intelligent Crimping System Technology includes a pressure sensor that monitors the crimping force of each crimp and provides the operator a visual and audible alert if the force is below specifications. Utilizes four indenters to make each compression. State of the art 18 V Lithium-ion (Li-ion) battery provides 70% more cycles per charge and faster cycle times. Smart chargers control the charging current, charging voltage and battery temperature to maximize battery life.



EK6ATLX QUAD POINT DIELESS COMPRESSION TOOL

Kit includes: tool, (2) batteries, charger, and case.

PART #	HEAD	BATTERY	CHARGER	WEIGHT
EK6ATLX11	Dieless	18 V (4Ah)	120 VAC	12 lbs.
EK6ATLX12	Dieless	18 V (4Ah)	12 VDC	12 lbs.



EK6FTLX QUAD POINT DIELESS COMPRESSION TOOL

Kit includes: tool, (2) batteries, charger, and case.

PART #	HEAD	BATTERY	CHARGER	WEIGHT
EK6ATLX11	Dieless	18 V (4Ah)	120 VAC	11 lbs.
EK6ATLX12	Dieless	18 V (4Ah)	12 VDC	11 lbs.



EK6FTLX DIELESS COMPRESSION TOOL

Kit includes: tool, (2) batteries, charger, and case.

PART #	HEAD	BATTERY	CHARGER	WEIGHT
EK6ATLX11	Dieless	18 V (4Ah)	120 VAC	15 lbs.
EK6ATLX12	Dieless	18 V (4Ah)	12 VDC	15 lbs.

BATTERY POWERED COMPRESSION TOOLS

Intelligent Crimping System Technology includes a pressure sensor that monitors the crimping force of each crimp and provides the operator a visual and audible alert if the force is below specifications. State of the art 18 V Lithium-ion (Li-ion) battery provides 70% more cycles per charge and faster cycle times. Automatic Retraction Stop (ARS) which retracts the ram just enough to get ready for the next cycle saving time and energy.

EK1230LX 12 TON PISTOL TYPE COMPRESSION TOOL

Kit includes: tool, (2) batteries, charger, and case.

PART #	HEAD	BATTERY	CHARGER	WEIGHT
EK1230LX11	Y-35	18 V (4Ah)	120 VAC	15 lbs.
EK1230LX12	Y-35	18 V (4Ah)	12 VDC	15 lbs.

EK1230L with 1.20 IN (30mm) opening uses Greenlee KC12, KA12 & KD12 crimping dies plus all industry "U" style crimping dies.



EK1240LX 12 TON PISTOL TYPE COMPRESSION TOOL

Kit includes: tool, (2) batteries, charger, and case.

PART #	HEAD	BATTERY	CHARGER	WEIGHT
EK1240LX11	Y-750	18 V (4Ah)	120 VAC	15 lbs.
EK1240LX12	Y-750	18 V (4Ah)	12 VDC	15 lbs.

EK1240L with 1.65 IN (42mm) opening uses Greenlee KC12, KA12 & KD12 crimping dies plus all industry "U" style crimping dies.



EK1240KLX 12 TON PISTOL TYPE COMPRESSION TOOL

Kit includes: tool, (2) batteries, charger, and case.

PART #	HEAD	BATTERY	CHARGER	WEIGHT
EK1240KLX11	Kearney™	18 V (4Ah)	120 VAC	15 lbs.
EK1240KLX12	Kearney™	18 V (4Ah)	12 VDC	15 lbs.

EK1240KL uses Kearney™ PH2 style crimping dies.



BATTERY POWERED COMPRESSION TOOLS

Intelligent Crimping System Technology includes a pressure sensor that monitors the crimping force of each crimp and provides the operator a visual and audible alert if the force is below specifications. State of the art 18 V Lithium-ion (Li-ion) batteries and Automatic Retraction Stop (ARS) which retracts the ram just enough to get ready for the next cycle saving time and energy. Forward handle pistol design provides optimal center of gravity.



U-DIE ADAPTER

PART #
PUADP-1



EK1550LX 12 COMPRESSION TOOL

Kit includes: tool, (2) batteries, charger, and case.

PART #	HEAD	BATTERY	CHARGER	WEIGHT
EK1550LX11	Y-46	18 V (4Ah)	120 VAC	15 lbs.
EK1550LX12	Y-46	18 V (4Ah)	12 VDC	15 lbs.



EK1550LX 15 TON COMPRESSION TOOL

Kit includes: tool, (2) batteries, charger, and case.

PART #	HEAD	BATTERY	CHARGER	WEIGHT
EK1550FLX11	Kearney™	18 V (4Ah)	120 VAC	15 lbs.
EK1550FLX12	Kearney™	18 V (4Ah)	12 VDC	15 lbs.



05167



52178



52180

ACCESSORIES

PART #	DESCRIPTION
05167	18 Volt Lithium-ion (4.0Ah)
52178	120 VAC Lithium-ion battery charger
52180	12 VDC Lithium-ion battery charger

BATTERY POWERED COMPRESSION TOOLS

The Streamlined tools were developed after listening to feedback from our customers. This new tool platform is the culmination of almost three years of research and development and will stand up to the most demanding tasks that linemen face every day. The SL-BND 6 Ton Tool offers a choice of 11 Jaw types including six compression heads and four cutting heads. The Operator can quickly change between head types with the pull-pin design. The SL-BND Streamline tool not only carries a 5 year warranty on the tool but on the battery and charger as well.

SL-BND 6 TON COMPRESSION TOOL

Kit includes: tool, (2) batteries, charger, case.

PART #	COMPRESSION HEAD	BATTERY	CHARGER	WEIGHT
SL-BNDBGAT	BG and D die	14.4 V (4Ah)	120 VAC	8.2 lbs.
SL-BNDOAT	O and D die	14.4 V (4Ah)	120 VAC	8.2 lbs.
SL-BNDKAT	Kearney™ die	14.4 V (4Ah)	120 VAC	8.2 lbs.



SLBG-JAW



SLK-JAW



SL-CUT



SLGW-Jaw



SLO-JAW



SLND3-JAW



SLXPJ-JAW



SL-CHCUAL



SL-CHACSR



SLCB-JAW

INTERCHANGEABLE HEADS FOR SL-ND

PART #	DESCRIPTION
SLBG-JAW	BG Nose die and D die
SLK-JAW	Kearney™ die
SLO-JAW	O Nose die and D die
SLND3-JAW	Snub nose D3
SLXPJ-JAW	X, P, J grooves

ACCESSORY HEADS FOR SL-ND

PART #	DESCRIPTION
SLCUT-JAW	Cuts 4/0 ACSR, 3/8" guy wire
SLGW-JAW	3/8" EHS guy wire, 4/0 ACSR
SL-CHCUAL	Cuts 500 MCM Cu, 1" Al
SL-CHACSR	Cuts 336 ACSR, 350 MCM Cu/Al
SLCB-JAW	Cable bender, 1000 MCM capacity

BATTERY POWERED COMPRESSION TOOLS

Both the SL-630 and SL-750 are designed to crimp Anderson style lugs. 6.2 tons of compression force is achieved when the tool advances and bypasses at the predetermined pressure. Advance and retract buttons on the tool handle allow for one hand operation, freeing the other hand to maneuver the cable.



SL-630



REC-B6630

6.2 TON OPEN HEAD DIELESS COMPRESSION TOOLS

Kit includes: tool, (2) batteries, charger, case.

PART #	HEAD	CAPACITY	BATTERY	CHARGER	WEIGHT
SL-630	Dieless	500 MCM	14.4 V (4Ah)	120 VAC	10.6 lbs.
REC-B6630	Dieless	500 MCM	14.4 V (4Ah)	120 VAC	11.3 lbs.



SL-750



REC-B6750

6.2 TON FLIP TOP DIELESS COMPRESSION TOOLS

Kit includes: tool, (2) batteries, charger, case.

PART #	HEAD	CAPACITY	BATTERY	CHARGER	WEIGHT
SL-750	Dieless	750 MCM	14.4 V (4Ah)	120 VAC	10.6 lbs.
REC-B6750	Dieless	750 MCM	14.4 V (4Ah)	120 VAC	11.7 lbs.

BATTERY POWERED COMPRESSION TOOLS

Utilizing the streamline design and replacing the traditional "C" head with a smaller, lightweight, latched head design makes the new SL-510 the lightest 12 Ton tool on the market today. The new SL-510 will deliver 12 Tons of compression force, utilizing all industry standard "U" dies. The REC-6510K battery powered compression tool is designed to accept Kearney WH-2, PH-2 and WH-3 style dies. The REC-6510K has a full 12-Ton capacity and its 1.5 inch jaw opening accepts lugs up to 1033 MCM.



SL-BC510



REC-B6510

12 TON COMPRESSION TOOL

Kit includes: tool, (2) batteries, charger, case.

PART #	HEAD	CAPACITY	BATTERY	CHARGER	WEIGHT
SL-BC510	Y750	1.65"	14.4 V (4Ah)	120 VAC	16 lbs.
REC-B6510	Y750	1.65"	14.4 V (4Ah)	120 VAC	15.9 lbs.



SL-B510



REC-B6510K

12 TON COMPRESSION TOOL

Kit includes: tool, (2) batteries, charger, case.

PART #	HEAD	CAPACITY	BATTERY	CHARGER	WEIGHT
SL-B510	Flip Top Y750	1.65"	14.4 V (4Ah)	120 VAC	12.5 lbs.
REC-B6510K	Kearney™	1.5"	14.4 V (4Ah)	12 VDC	13.5 lbs.

BATTERY POWERED COMPRESSION TOOLS

These 15 Ton Compression Tools are built on a similar platform as our SL-ND tool, the most robust and versatile streamlined tool in the industry. The new SL-B610 & SL-BC610 will deliver 15 tons of compression force, utilizing all industry standard "P" dies. The SL-B610 and SL-BC610 is capable of accepting lugs up to 1500 MCM copper and 1250 MCM Aluminum.



SL-B610



SL-BC610

15 TON COMPRESSION TOOLS

Kit includes: tool, (2) batteries, charger, case.

PART #	HEAD	BATTERY	CHARGER	WEIGHT
SL-B610	Flip top Y-46 style	14.4 V (4Ah)	120 VAC	16.5 lbs.
SL-BC610	Open Y-46 style	14.4 V (4Ah)	120 VAC	20 lbs.



BP-84



CH-94

ACCESSORIES

PART #	DESCRIPTION
BP-84	14.4 Volt Lithium-ion (4.0Ah)
CH-94	Tool charger

LOW-PRESSURE HYDRAULIC COMPRESSION TOOLS

All of these hydraulic tools can be supplied assembled with couplers and hoses ready for field use.



All of these tools are pressure tested prior to shipment.



12 TON COMPRESSION TOOL

This tool has a 1.65" jaw opening that accepts U-Dies and develops 12 tons of force. Crimps up to 750 MCM copper and aluminum. It has a powered advance and retract feature and the relief valve signals the operator when the crimp is complete. Operating pressure is between 1,500 to 2,000 PSI with a flow rate of 3 - 9 GPM and weighs 19.7 lbs.

Order couplers separately.

PART #
LPK1240

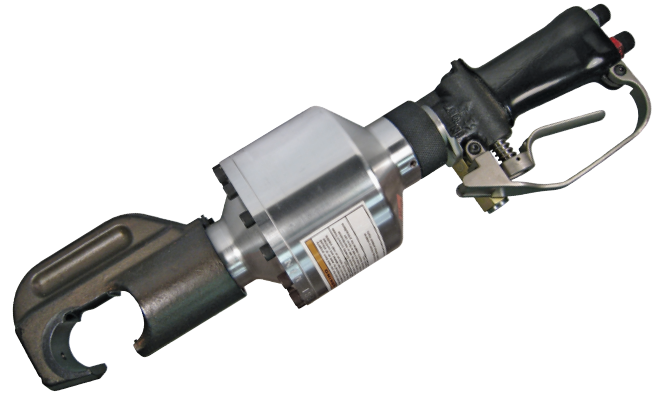

CT10066AN with Burndy Y750 Head

CT10 COMPRESSION TOOLS

Available in 2 models, these tools provide up to 12 tons of force. Operating pressure is between 1,650 to 2,500 and the flow rate is 3-9 GPM. Order couplers separately.

PART #	HEAD TYPE	CAPACITY
CT10016N	Y-35	500 Cu / 636 Al
CT10066AN	Y-750	750 MCM Cu / Al



15 TON COMPRESSION TOOL

Crimps up to 1500 MCM copper and 1250 MCM aluminum head rotates for easy tool positioning. Relief valve assures 15 Ton crimp with 1,500-2,500 PSI and signals operator when crimp is complete. Compatible with both open and closed center systems. Assist handle is available to facilitate two hand operation when needed. Accepts P-style dies without adaptors. Weighs 24.5 lbs.

PART #
LPK1550FT



15 TON COMPRESSION TOOL

Crimps up to 1500 MCM copper and 1250 MCM aluminum head rotates for easy tool positioning. Compatible with both open and closed center systems. Operating pressure is between 1,650 to 2,500 and the flow rate is 3-9 GPM. Accepts P-style dies without adaptors. Weighs 29 lbs.

PART #
CT15036GN

See page 311-312 for pumps & hoses.



DIELESS COMPRESSION HEAD
Designed to crimp Anderson connectors #10 sol – 500 MCM bare copper and #10 str – 500 MCM bare aluminum. Supplied with 3/8" male screw type coupler.

PART #
EP-630HA



DIELESS COMPRESSION HEAD
Anderson style head has a flip-top opening and a pull-pin locking mechanism to accept larger connectors up to 750 MCM. Supplied with 3/8" male screw type coupler.

PART #
EP-750HA

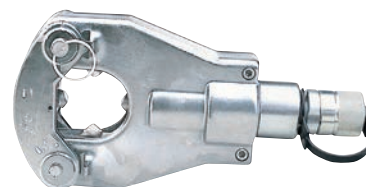

DIELESS COMPRESSION HEAD
These tools utilize four indenters to make the crimp. The compact, flip-top head rotates a full 360°. Crimps #4 to 750 MCM copper connectors and #4 to 500 MCM aluminum. Supplied with 3/8" male screw type coupler.

PART #
RK06FT



12 TON COMPRESSION HEAD
The Y35 incorporates a C-shaped head with a 1" jaw opening. Accepts U-type dies and is commonly used on #8 - 750 MCM copper and #6 - 750 MCM Aluminum. Supplied with 3/8" male screw type coupler.

PART #
Y35BH



12 TON COMPRESSION HEAD
The 131LN Hydraulic C-shaped head rotates 180°, has a jaw opening of 1.65". These tools accept U-type dies and are commonly used on conductor sizes from #6 through 750 MCM. Supplied with a self-lock quick male coupler.

PART #
RHC-131LN



12 TON COMPRESSION HEAD
C-head that accepts all U-type dies used with conventional 12 Ton compression tools. The larger jaw opening of 1.65" accepts conductors and mid-span sleeve connections up to 750 MCM. Supplied with 3/8" male coupler.

PART #
EP-510HC



15 TON COMPRESSION HEAD
This tool operates on 10,000 PSI and accepts S-type dies. Accommodates conductor sizes up to 1500 copper, 1000 aluminum and 795 ACSR. Supplied with male 10,000 PSI hydraulic coupler.

PART #	DESCRIPTION
Y45	Hydraulic head
PT6515	U-die adapter



15 TON COMPRESSION HEAD
This tool uses P-type dies and operates with any 10,000 PSI pump. It has a conductor range of #8 - 1500 copper and # 8 - 1250 ACSR. Supplied with male 10,000 PSI hydraulic coupler.

PART #	DESCRIPTION
Y46LWSBA	Hydraulic head
PUADP-1	U-die Adapter



15 TON COMPRESSION HEAD
C-head with protective rubber boot that accepts all Huskie HT61 series and Burndy "P" type dies. When used with a Huskie PU-15 die adapter it will accept all "U" type dies used with any 12 Ton tool. Supplied with 3/8" male coupler.

PART #	DESCRIPTION
EP-610H	Hydraulic head
PU-15	U-die adapter

CALL TALLMAN TO **RENT** COMPRESSION TOOLS & DIES.



60 TON COMPRESSION TOOL

This single acting tool accepts Alcoa 60 Ton series dies and Burndy L-type dies. It operates with most 10,000 PSI hydraulic power sources. Includes storage case.

PART #
TE60T



100 TON COMPRESSION TOOL

This press can be set to single or double acting. It accepts Alcoa and Burndy 100 Ton dies. It has a ram stroke of .98", measures 6.25" wide x 15" high and weighs 95 lbs. Includes storage case.

PART #
TE100SDP



60 TON COMPRESSION TOOL

Single acting, 60 Ton press that is designed to compress sleeves and lugs on ACSR and ACAR transmission and distribution cables. Ideal for substation construction and are operable from any 10,000 PSI pumping source with proper oil capacity. These tools are made to be portable for easy maneuverability. Will accept any shell type dies currently used with Alcoa or Burndy 60 Ton presses.

PART #
EP-60WD



100 TON COMPRESSION TOOL

100 Ton compression head for full tension, transmission and substation connections and requires an external 10,000 PSI, double-acting pumping source. Accepts shell-type dies currently used with Alcoa 100 Ton compression heads. This double acting compression head is designed to operate from Huskie Tools pump models R-14EAD, HPG-4 or any 3/4 HP high-pressure, double-acting pump with the proper oil capacity.

PART #
EP-100WD

COMPRESSION DIES & ADAPTERS



O-DIES

Used in the Kearney™ O series compression tools.



W-DIES

Used in MD6, MD7 and other similar 6 Ton compression tools.



U-DIES

Used in Y-35, Y-39, Y-750 and other similar 12 and 14 Ton compression tools.

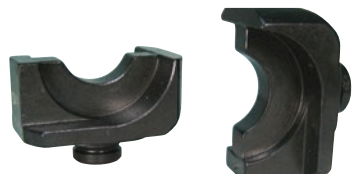

H-DIES

Used in the Kearney™ WH-2 & WH-3 compression tools.



P-DIES

Used in the Y-46 and other similar 15 Ton compression tools.



S-DIES

Used in the Y-45 and other similar 15 Ton compression tools.



CUTTING DIE

Fits MD6, MD7 and other similar 6 Ton compression tools. Capacity # 4 to 4/0 ACSR.



Y-46 U-DIE ADAPTER

Allows the use of U-Dies in the Y-46 and other similar 15 Ton compression tools.



Y-45 U-DIE ADAPTER

Allows the use of U-Dies in the Y-45 and other similar 15 Ton compression tools.

PART #
W28K

PART #
PUADP-1

PART #
PT6515



TE60-CASE



TE100-CASE

DIE CASE

Storage case with foam inserts for die storage.

PART #	CAPACITY
TE60-CASE	15 Compression dies
TE100-CASE	8 Compression dies

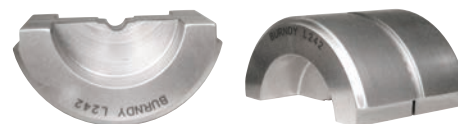

L-type dies

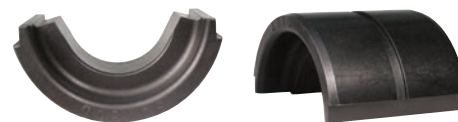

60 Ton die series

60 TON DIES

Used in TE60T and similar 60 Ton compression tools.



100 Ton die series

100 TON DIES

Used in TE100SDP and other similar 100 Ton compression tools.

BATTERY POWERED HYDRAULIC PUMP

The EHP700LU operates from a single 18 V Lithium-ion battery with on board storage for a second battery. Offers 3 in 1 program settings for crimping, cutting, and punching operations. Intelli-Crimp™ technology alerts the user by audible signal and visual alert if pressure of 10,000 PSI is not achieved. Includes shoulder strap, 6' corded remote, two 18 V Lithium-ion batteries, and 120V charger.



PART #
EHP700LU

BATTERY POWERED HYDRAULIC PUMP

Runs on two 14.4 Volt Huskie BP-80 series batteries. The REC-P1 is supplied with a push button remote control that allows the operator to advance, hold, and retract when needed. The user is never committed to a full cycle and can always back off at any time during the advance– even when the pump is under pressure. High pressure, non-conductive hose can be attached to a 360° moveable swivel port on the pump. This swivel port allows the user to position the hose to fit in confined aerial buckets and manholes. Can operate up to single acting 60 Ton press.



PART #
REC-P1

ELECTRIC POWERED HYDRAULIC PUMP

The R-14EF remote operated pump gives the operator complete control. Push buttons permit the user to advance and retract at will. The user is never committed to a full cycle, and can always back off at any time during the advance even under pressure. This feature allows cuts and crimps can be adjusted as necessary, simply by stopping the advance or retract mode. A 10 foot remote control cable provides both safety and convenience. The user can set up an operation and then move away from the work site before engaging the tool. An over-ride switch on the pump allows full control at the pump motor. The low amperage of this pump allows it to be used virtually anywhere.



PART #
R-14EF

ELECTRIC POWERED HYDRAULIC PUMP

A 115V 5/8 HP electric motor provides 10,000 PSI. It features a two-stage pump for rapid advance, a high-pressure safety relief valve, a 10' corded remote control and a factory filled oil reservoir. Storage case included.



PART #
PENUTC



SINGLE ACTING HYDRAULIC PUMP

This pump features a 6 HP Briggs & Stratton engine. The manual control valve is mounted directly onto the pump. This pump is used for single acting tools only.

PART #	PRESSURE	WEIGHT
PG1203-CP	10,000 PSI	154 lbs.

DOUBLE ACTING HYDRAULIC PUMP

This model has a 5.5 HP Honda OHV-type engine. This pump has a 10' corded remote control and can be set to run either single or double acting tools.

PART #	PRESSURE	WEIGHT
PG1203/45-CP	10,000 PSI	154 lbs.



DOUBLE ACTING HYDRAULIC PUMP

A self-contained high pressure pump, with manual operation. It is equipped with a 4 HP Briggs & Stratton engine. A four-way valve controls the hydraulic fluid direction for the advance and retract modes. One double acting tool can be operated or two single acting tools at one time. Connection to one port for single acting tools will work since the control valve will dump the fluid when shifted to the retract position. The pump is very compact and comes with carrying handles.

PART #	PRESSURE	WEIGHT
HPG-4	10,000 PSI	74 lbs.



DOUBLE ACTING HYDRAULIC PUMP

Self-contained high pressure pump, with manual operation. It is equipped with a 5.5 HP Honda engine. A four-way valve controls the hydraulic fluid direction for the advance and retract modes. One, double-acting tool can be operated or two, single-acting tools at one time. Connection to one port for single acting tools will work since the control valve will dump the fluid when shifted to the neutral position. The pump is very compact and comes with carrying cage.

PART #	PRESSURE	WEIGHT
HPM-P3	10,000 PSI	105 lbs.



HIGH-PRESSURE HYDRAULIC COUPLERS

Dirt caps Included.

PART #	THREAD	TYPE
TE3050-3-C	3/8" External	Female
TE3010-3-C	3/8" Internal	Male



HIGH-PRESSURE HYDRAULIC HOSE

10,000 PSI hose is used with high pressure cutting and compression tools. Standard sets include male couplers on both ends. Female couplers available.

PART #	DIAMETER	LENGTH
HP06-10-MM	3/8"	10'
HP06-25-MM	3/8"	25'
HP06-50-MM	3/8"	50'
HP06-100-MM	3/8"	100'

LOW-PRESSURE HYDRAULIC POWER UNITS



HYDRAULIC POWER UNIT

It's portable, lightweight and quiet. It comes standard with an 18 HP Briggs & Stratton engine. With an open-center system, this pump runs most low pressure tools.

PART #	FLOW RATE	PRESSURE	WEIGHT
GT18B02	5 or 8 GPM	2,000 PSI	330 lbs.



HYDRAULIC POWER UNIT

The 13 HP 4-stroke Honda engine has an easy-pull recoil start. Supplied with quick-release telescoping handles and low-oil alert and shutdown system. Open center system.

PART #	FLOW RATE	PRESSURE	WEIGHT
F13	5 or 8 GPM	2,000 PSI	168 lbs.



HYDRAULIC POWER UNIT

This twin circuit hydraulic power unit can operate two tools at 5 or 8 GPM simultaneously. Each of the two open center circuits is optimized to deliver ideal flows and pressures to both Type 1 and Type 2 hydraulic tools.

PART #	FLOW RATE	PRESSURE	WEIGHT
HP28B02	5 or 8 GPM	2,000 PSI	360 lbs.



HYDRAULIC POWER UNIT

This hydraulic power unit is optimized to deliver open center flows and pressures to both Type 2 and Type 3 hydraulic tools. Its powerful 23 HP Briggs & Stratton engine delivers the power to keep tools working uninterrupted all day.

PART #	FLOW RATE	PRESSURE	WEIGHT
GT23B02	8 or 12 GPM	2,000 PSI	340 lbs.

LOW-PRESSURE HYDRAULIC HOSE & COUPLERS

2,250 PSI hose is used with low pressure hydraulic tools. These hoses can be supplied with or without flat face couplers. Black hose is vulcanized, wire-braided reinforced, Red hose is non-conductive.



Shown with couplers.



Shown without couplers.

LOW-PRESSURE HYDRAULIC HOSE

Black hose is vulcanized, wire-braided reinforced.

PART #	DIAMETER	LENGTH	COLOR
TELPV08-25-MF	1/2"	25'	Black
TELPV08-50-MF	1/2"	50'	Black

Other lengths of hose are available.

LOW-PRESSURE HYDRAULIC HOSE

Red hose is non-conductive.

PART #	DIAMETER	LENGTH	COLOR
TELPNC06-08	3/8"	8'	Red
TELPNC06-10	3/8"	10'	Red

Other lengths of hose are available.



FF3716FP



FF3726FP



2066-6-8S



54923



54925

COUPLERS AND FITTINGS

PART #	TYPE	CONNECTION
FF3716FP	Female coupler	3/8" Internal thread
FF3718FP	Female coupler	1/2" Internal thread
FF3726FP	Male coupler	3/8" Internal thread
FF3728FP	Male coupler	1/2" Internal thread
2066-6-8S	Swivel fitting	3/8" NPT female to 3/4-16 o-ring
03-6900-6-6	Swivel fitting	3/8" NPT female to 9/16-18 o-ring
54923	Male coupler	3/4-16 SAE external o-ring thread
54925	Female coupler	3/4-16 SAE external o-ring thread



HYDRAULIC INTENSIFIER

Increases the pressure of the hydraulic system of a vehicle so that high-pressure tools can be operated without an additional power unit. It operates on either open or closed center systems and has an optimum operating pressure of 1,800 PSI at 6 GPM. Flow range is 4 - 7 GPM. Includes a 10' non-conductive, low-pressure twin-line hose and 8' of high-pressure hose.

PART #
TEHIS-810



PVA0021

HYDRAULIC FLOW CONTROL VALVE

4-way, 3-position valves can be connected directly to the tool or used remotely with hoses. Output side couplers included.

PART #	DESCRIPTION
PVA0021	For single acting tools
PVA0022	For double acting tools



HYDRAULIC FLOW CONTROL VALVE

Operates off of a vehicle's hydraulic circuit. It can accept a flow of up to 30 GPM and reduce it to a maximum of 10 GPM allowing the correct flow to the hydraulic tool.

PART #
HFC30



HYDRAULIC FLOW CONTROL VALVE

Used to control the direction of the flow to the tools, forward or reverse. Includes couplers.

PART #
49913



HYDRAULIC INTENSIFIER

Works on both open and closed center systems and produces 10,000 PSI. Input pressure is from 1,000 to 2,000 PSI and has a flow rate between 4 - 8 GPM. Couplers & hose sold separately.

PART #
HB10



HYDRAULIC FLOW & PRESSURE GAUGE

Used to test the hydraulic circuitry by measuring the back pressure, resistance and flow. Includes couplers.

PART #
04182

WEJTAP TOOLS

WEJTAP™ INSTALLATION TOOLS

The two interchangeable, color-coded heads accept all Wejtap™ connectors and stirrups. These tools react to the discharge of power boosters within the tool body. Each booster shell is color-coded for easy identification and provide the necessary force required to correctly drive the wedge of the different size taps. Both heads feature a universal spline for use with hotsticks.



SMALL WEJTAP™ TOOL

For red & blue connectors
#8 through 350 kcmil, ACSR and stirrups.

PART #
WTRB

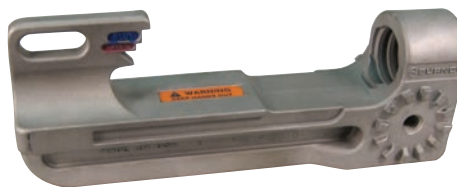

SMALL HEAD ONLY

Red & Blue coded connectors.

PART #
WTHRB1S

LARGE WEJTAP™ TOOL

For yellow connectors 336 through 1590 kcmil.

PART #
WTY

LARGE HEAD ONLY

Yellow coded connectors.

PART #
WTHY1S



COMPLETE WEJTAP™ TOOL KIT

PART #
WTRBYK



POWER UNIT

Fits both small & large heads.

PART #
WTB

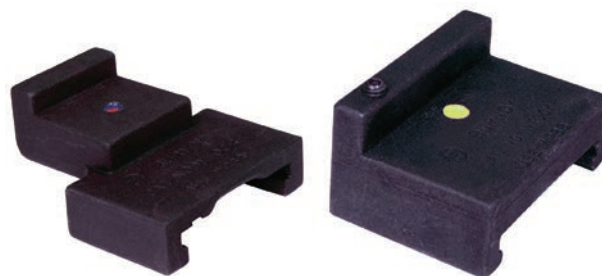

REMOVAL CLIPS

These clips are used with the Wejtap™ Tools to remove connectors and stirrups with minimal damage to the conductor.

PART #	TAP COLOR
WTOCBR	Blue & Red
WTOCY	Yellow

CONSISTS OF THE FOLLOWING IN A STORAGE CASE:

PART #	DESCRIPTION
WTHRB1S	Small head only
WTHY1S	Large head only
WTB	Power unit
WTOCBR	Blue & red removal clip
WTOCY	Yellow removal clip
WTCK	Cleaning kit



WHSTA



WHSWHADP



WHSWB



WHSCWH



WHSK1



WHSPBC



WHSGB

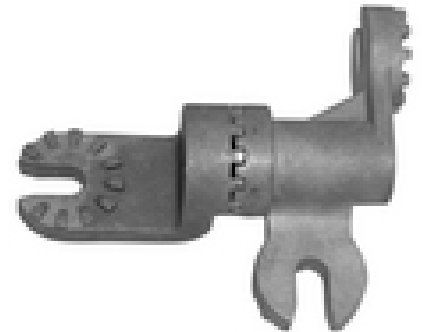

WHSSADP

WEJTAP™ HOTSTICK KIT

PART #	DESCRIPTION
WHSK1	Complete Wejtap™ hotstick kit

WEJTAP™ HOTSTICK ACCESSORIES (INCLUDED IN KIT)

WHSCWH	C-wedge holder clamp assembly
WHSWHADP	Wedge holder adapter link
WHSWB	Hotstick wire brush
WHSPBC	Piggyback clamp assembly
WHSGB	Geared breech drive
WHSSADP	90° Angle adapter
WHSTA	Tool activator
WHSCC	Carrying case

AMPACT POWDER ACTUATED WEDGE TOOLS

Precision designed tools for installing taps and stirrups to solid or stranded conductor, aluminum to aluminum, copper to aluminum or copper to copper. These tools are actuated by firing a special powder-loaded shell within the tool. The shells are color coded to indicate the powder charge and to correspond with the color coding of the taps & stirrups.

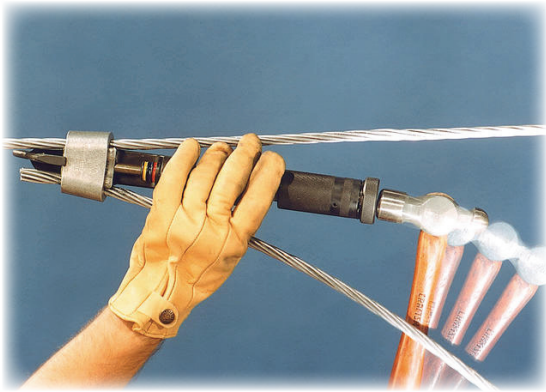

SMALL AMPACT TOOL: RED, WHITE & BLUE TAPS

#8 through 350 kcmil.

PART #
69437



LARGE AMPACT TOOL FOR YELLOW TAPS

336 through 1192 kcmil.

PART #
69611

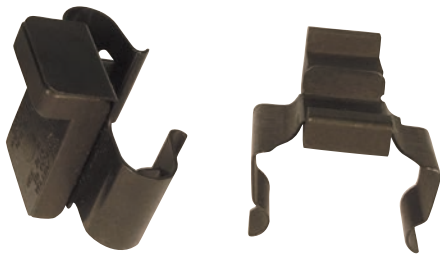

TAKE-OFF CLIPS

The four types of take-off clips are used with the Ampact Tools to remove terminated taps and stirrups from conductors.

PART #	TAP COLOR
69684	Red
69685-1	Blue
69947	White
69847	Yellow



AMPACT TOOL HEADS

PART #	DESCRIPTION
47667-8	Small head only
69633-2	Large head only
69612	Universal power unit fits both small & large heads

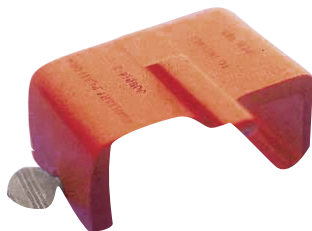

AUXILIARY PLATFORM

Required when installing AMP red-coded copper wedge connectors.

PART #
306814-3

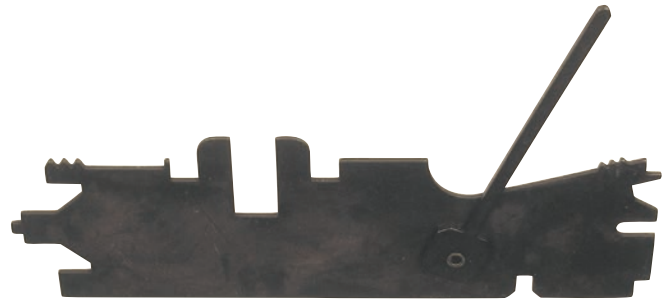

CLEANING TOOL

PART #
314199-1

AMPACT POWDER ACTUATED WEDGE TOOLS

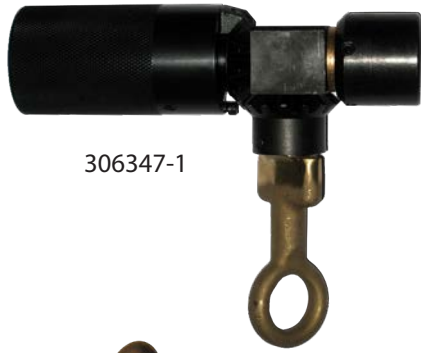

306347-1



69816



306348-1



306350-2

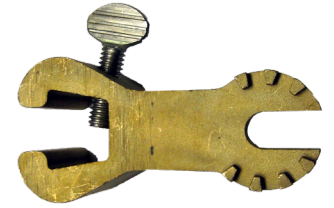

306349-1

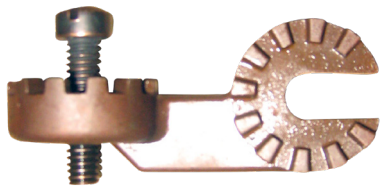

69833-1



69674
(Sold Separately)



306349-2

AMPACT ACCESSORIES HOTSTICK KIT (PART # 69610-1)

PART #	ITEMS INCLUDED IN KIT
306347-1	Geared breech
69816	Piggyback clamp for wire sizes #8 to 556.5 - 26/7 ACSR (990 Amps continuous service)
306348-1	Wedge holder
306350-2	"C" Holder
306349-1	AMPACT tool holder (for tool 69611)
69833-1	90° Adapter
306349-2	Tool holder (for tool 69437)

RELATED COMPONENTS (SOLD SEPARATELY)

PART #	DESCRIPTION
69674	Hammer head
69883	Piggyback clamp for wire sizes 795.0 to 1192.5 - 45/7 ACSR (not shown)
69900	Combination "C" wedge (not shown)

FIBERGLASS SHOTGUN STICKS

INTERNAL ROD SHOTGUN STICKS

The operating rod is inside the main pole and is available in the fixed length style only.



8204

FIXED LENGTH STYLE

Add "U" suffix for universal end.

PART #	LENGTH	STORAGE BAG
8204	4'6"	TE2605
8206	6'6"	TE2609
8208	8'6"	TE2611
8210	10'6"	TE2615
8212	12'6"	TE2619

EXTERNAL ROD SHOTGUN STICKS

The operating rod is outside of the main pole making all parts easily accessible for cleaning an inspection.

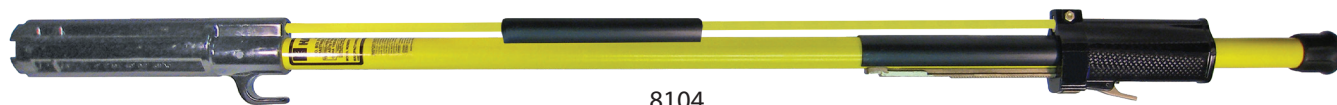

8104

FIXED LENGTH STYLE

Add "U" suffix for universal end.

PART #	LENGTH	STORAGE BAG
8104	4'6"	TE2605
8106	6'6"	TE2609
8108	8'6"	TE2611
8110	10'6"	TE2615
8112	12'6"	TE2619

HINGED STYLE

Add "U" suffix for universal end.

PART #	LENGTH	STORAGE BAG
13412	6'6"	TE2630
13413	8'6"	TE2631
13414	10'6"	TE2632
13415	12'6"	TE2633

TELESCOPING STYLE

Add "U" suffix for universal end.

PART #	RETRACTED	LENGTHS	STORAGE BAG
8158	5'1"	5'1", 6'6", 8'	TE2607
81611	6'6"	6'6", 8', 9'6", 11'	TE2609
81-814	8'	8', 10', 12', 14'	TE2610
81-1018	9'10"	9'10", 11'9", 13'6", 15'6", 17'6"	TE2614

FIBERGLASS SHOTGUN STICKS

EXTERNAL ROD SHOTGUNS

The operating rod is outside of the main pole making all parts easily accessible for cleaning an inspection.



C403-0292

FIXED LENGTH STYLE

Add "A" suffix for universal end fitting.

PART #	LENGTH	STORAGE BAG
C403-0291	4-1/2'	TE2605
C403-0292	6-1/2'	TE2609
C403-0293	8-1/2'	TE2611
C403-0294	10-1/2'	TE2615
C403-0295	12-1/2'	TE2619

TELESCOPING STYLE

PART #	RETRACTED	LENGTHS	STORAGE BAG
C403-1035	5'3"	5'7", 6' 9", 8'	TE2607
C403-1036	8'3"	8'7", 10'4", 12'2", 14'	TE2611

TELESCOPING STYLE WITH UNIVERSAL END

PART #	RETRACTED	LENGTHS	STORAGE BAG
C403-3060	5'6"	5'10", 7'1", 8'4"	TE2607
C403-3061	8'6"	8'10", 10'8", 12'6", 14'4"	TE2611



C403-0342

HINGED STYLE

Add "A" suffix for universal end fitting.

PART #	FOLDED	EXTENDED	STORAGE BAG
C403-0296	3'4"	6'9"	TE2630
C403-0297	4'4"	8'8"	TE2631
C403-0298	5'4"	10'8"	TE2632
C403-0299	6'4"	12'8"	TE2633
C403-0342	7'4"	14'8"	TE2634
C403-0343	8'4"	16'8"	TE2635

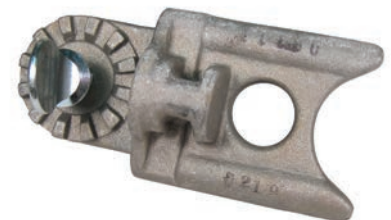

UNIVERSAL SHOTGUN ADAPTER

Converts any shotgun to use all universal tool attachments.

PART #
M1867

UNIVERSAL & DISCONNECT STICKS



4678-6



460-6

SINGLE SPLINE

PART #	LENGTH	STORAGE BAG
567-4	4'	TE2604
567-6	6'	TE2608
567-8	8'	TE2610
567-10	10'	TE2614
567-12	12'	TE2618

SWITCH STICKS

PART #	LENGTH	STORAGE BAG
460-4	4'	TE2604
460-6	6'	TE2608
460-8	8'	TE2610
460-10	10'	TE2614
460-12	12'	TE2618

DOUBLE SPLINE

PART #	LENGTH	STORAGE BAG
4678-4	4'	TE2604
4678-6	6'	TE2608
4678-8	8'	TE2610
4678-10	10'	TE2614
4678-12	12'	TE2618

DISCONNECT STICKS

PART #	LENGTH	STORAGE BAG
461-4	4'	TE2604
461-6	6'	TE2608
461-8	8'	TE2610
461-10	10'	TE2614
461-12	12'	TE2618

TELESCOPING, UNIVERSAL & DISCONNECT STICKS

A variety of lengths allows the lineman to perform many routine jobs from the ground. The universal end fitting accepts a wide range of attachments to complete many different jobs with one tool. See pages 332 - 336 for universal attachments.

The top section of the Tip Lock style retracts and locks into the next section giving it double wall strength.

TIP LOCK STYLE, 7/8" TIP

PART #	RETRACTED	MAX LENGTH	STORAGE BAG
ST-225	5'	25'6"	TE2606
ST-230	5'2"	30'	TE2607
ST-235	5'3"	35'	TE2607
ST-240	5'5"	40'	TE2607

HEAVY DUTY, 1-3/32" TIP

PART #	RETRACTED	MAX LENGTH	STORAGE BAG
SH-216	4'10"	17'	TE2606
SH-200	5'	21'6"	TE2606
SH-250	5'2"	26'	TE2607
SH-230	5'3"	30'	TE2607
SH-235	5'3"	35'	TE2607

TRIANGULAR "NO-TWIST"

* Bucket sticks and canister

PART #	RETRACTED	MAX LENGTH	STORAGE BAG
HV-208*	2'2"	8'	06-185 stick holder
HV-312*	3'1"	12'	06-186 stick holder
HV-212	4'10"	12'7"	TE2606
HV-216	5'	16'9"	TE2606
HV-220	5'2"	21'	TE2607
HV-225	5'4"	25'6"	TE2607
HV-230	5'6"	30'	TE2607
HV-235	5'8"	35'	TE2608
HV-240	5'9"	39'6"	TE2608

MEASURING STICKS

Measuring Sticks are marked in feet and inches and have a large plastic hook.

PART #	RETRACTED	MAX LENGTH	STORAGE BAG
E-25	5'6"	25'	TE2607
E-30	5'6"	30'	TE2607
E-35	5'6"	35'	TE2607
E-40	5'6"	40'	TE2607
E-50	5'9"	50'	C-40



HV-208

MEASURING STICKS

Safely measure vertical heights. Available in English or Metric graduations.

Used to measure overhead lines, telephone, cable-TV, highway clearances, and structures. Other models and lengths available.



TELESCOPING MEASURING & DISCONNECT TOOL

Easy to read english and metric scales for measuring pole heights and conductor clearances from the ground.

PART #	MINIMUM LENGTH	MAXIMUM LENGTH	STORAGE BAG
C403-1022EM	5'7"	35'	TE2608



E-30

ROUND SHAFT MEASURING STICKS

Eye-level reading, no calculations required, the read-height is shown at the top of the base section. Positive locking buttons, spring-loaded, fast accurate and easy to extend. Standardization parts for quick and easy repair and replacement.

PART #	EXTENDED	RETRACTED
E-25	25'	65-3/4"
E-30	30'	65-3/4"
E-35	35'	65-3/4"
E-40	40'	65-3/4"
E-50	50'	69-3/16"



EV-30

TRIANGULAR SHAFT COMBINATION HOT STICK & MEASURING STICK

Open and close switches, disconnects, line fuses, as well as measure elevated heights. Eye-level reading, no calculations required, the read-height is shown at the top of the base section. Markings are printed in large easy to read numbers in feet and inches.

PART #	EXTENDED	RETRACTED
EV-25	25'6"	64"
EV-30	30'	66"
EV-35	35'	68"
EV-40	39'6"	69"

TELESCOPING HOT STICKS

A variety of lengths allow the lineman to perform many routine jobs from the ground. The universal end fitting accepts a wide range of attachments to complete many different jobs with one tool.



STANDARD DUTY, 1-1/16" TIP

PART #	RETRACTED	MAX LENGTH	STORAGE BAG
T403-2205	2'4"	7'2"	TE2602
T403-3240	3'	11"	TE2603
C403-1739	4'	23'	TE2604
C403-1023	4'8"	8'	TE2606
C403-1017	4'9"	12'	TE2606
C403-1018	4'11"	16'	TE2606
C403-1019	5'1"	20'	TE2607
C403-1020	5'3"	25'	TE2607
C403-1021	5'5"	30'	TE2607
C403-1022	5'7"	35'	TE2608
T403-3349	6'3"	40'	TE2609

HEAVY DUTY, 1-1/4" TIP

PART #	RETRACTED	MAX LENGTH	STORAGE BAG
C403-1597	4'8"	8'	TE2606
C403-1598	4'9"	12'	TE2606
C403-1599	4'11"	16'	TE2606
C403-1600	5'1"	20'	TE2607
C403-1601	5'3"	25'	TE2607
C403-1602	5'5"	30'	TE2607

VINYL STORAGE BAG

Protect your sticks. Other sizes and options available.

PART #
TE2611



UNIVERSAL & DISCONNECT STICKS

Designed to accept the universal tools shown on pages 332 - 336 and more.
Double spline sticks have a universal fitting on both ends. Made of 1-1/4" diameter FRP.



SINGLE SPLINE

PART #	LENGTH	STORAGE BAG
H1760-1	6'1"	TE2609
H1760	8'2"	TE2611



DOUBLE SPLINE

PART #	LENGTH	STORAGE BAG
H1760-3	6'3"	TE2609
H1760-4	8'3"	TE2611
H1760-10	10'3"	TE2615
H1760-12	12'3"	TE2619



UNIVERSAL STORM TOOL

The two rubber insulator skirts provide extra leakage distance and disrupts water paths that would otherwise run down the pole.

PART #	SIZE	STORAGE BAG
H1761	1-1/4" x 8'2"	TE2611

DISCONNECT STICKS

Designed primarily for opening and closing disconnect switches and cut outs as well as installing and removing open-link fuse links.

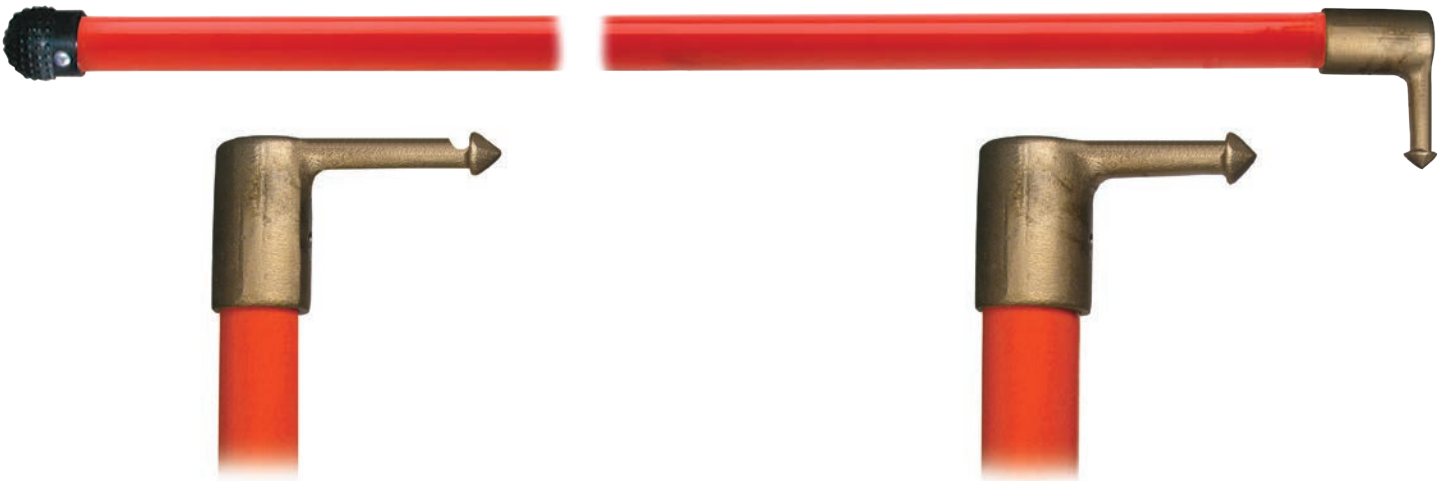

Switch stick head

Disconnect head

1-1/4" DIAMETER SWITCH STICKS

PART #	LENGTH	STORAGE BAG
H3046-12	6'	TE2608
H3046-13	8'	TE2610
H3046-14	10'	TE2614
H3046-17	12'	TE2618

1-1/2" DIAMETER DISCONNECT STICKS

PART #	LENGTH	STORAGE BAG
H3046-22	6'1"	TE2609
H3046-23	8'1"	TE2611
H3046-24	10'1"	TE2615
H3046-15	12'1"	TE2619

SPECIALTY HOT STICKS



TORQUE EXTENSION STICK FOR HYDRAULIC POWER TOOLS

This insulated stick permits hot-line work with hydraulic impact wrenches on bucket trucks. The 7/16" hex shank end connects to the wrench and the square end with detent-ball fitting accepts all 1/2" drive sockets, 75 ft. lb. rating.

PART #	SIZE
T403-3009	1-1/4" x 4'

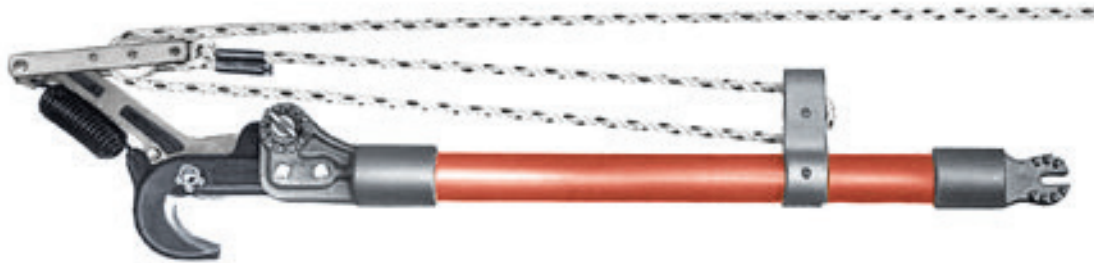

UNIVERSAL TREE TRIMMER

Designed to cut branches up to 1-1/2" in diameter, this trimmer is especially useful around energized conductors. The trimmer pole is 18" long and comes with 25 feet of rope.

PART #
H2106-4



Two-prong



Rotary prong



Rotary blade

TIE STICKS

Rotary Prong Tie Sticks are used for handling looped ties. Two-Prong Tie Sticks are used for handling hot ties with loops. Rotary Blade Tie Sticks have a swivel action for greater freedom of movement than fixed-blade sticks.

PART #	HEAD	END	LENGTH
H1855-19	Rotary prong	Universal	8'3"
H1855-20	Two-prong	Universal	8'4"
H1855-25	Rotary prong	Rotary blade	8'2"
H1855-26	Rotary blade	Universal	8'3"

SPECIALTY HOT STICKS



WIRE-HOLDING STICKS

These fiberglass tools can be used on or around energized conductors for forming, bending and positioning jumper wires and also for holding conductors during splicing operations. The gripper head has an eye so that other sticks can assist with heavy bending and has a capacity of #6 solid copper through 1590 ACSR. The head can be locked into three positions to engage and position conductors from almost any angle.

PART #	LENGTH
C403-3068	1-1/4" x 6'5"
C403-3069	1-1/4" x 8'5"



IMPACT ELBOW PULLER TOOLS

Used to remove elbow connectors from bushings of transformers. The integral hook on the tool head fits through the rubber eye of an elbow or the metal hook of a bushing cap adding extra control and pulling power to the grippers. Order grippers separately.



ELBOW PULLER TOOLS

PART #	LENGTH
C403-1851	4-1/2'
C403-1822	6'
C403-1850	8'



C403-0704

ELBOW GRIPPERS

PART #	RATING
C403-0704	15KV
C403-0613	25KV

34.5kV Grippers are available

ARC SNUFFER REMOVAL & REPLACEMENT TOOLS

These hot-line tools permit easy retrieval of broken arc snuffers and the installation of replacements without having to de-energize the URD bushings. The Removal Tool works like a bolt extractor. The damaged arc snuffer is removed by simply unscrewing the broken part. The Replacement Tool controls the alignment with a center post that snaps into the arc snuffer bore. The two steel lugs of the tool are inserted into the holes of the snuffer collar for tightening torque.



REMOVAL TOOL

PART #
C403-2037



REPLACEMENT TOOL

PART #
C403-2036

FIBERGLASS LADDERS & INSULATED PLATFORMS

SWIVEL HOOK LADDERS

Swivel Hook Ladders come standard with 8" hooks. 14" and 18" hooks can be special ordered. Standard Duty Ladders have 2" side rails and Heavy Duty Ladders have 2-1/2" side rails. Both styles have 14-1/2" between side rails.



REGULAR DUTY LADDERS

PART #	LENGTH	WEIGHT
H4904-8	8'	42 lbs.
H4904-10	10'	46 lbs.
H4904-12	12'	52 lbs.
H4904-14	14'	60 lbs.
H4904-16	16'	68 lbs.

HEAVY DUTY LADDERS

PART #	LENGTH	WEIGHT
H4905-8	8'	47 lbs.
H4905-10	10'	55 lbs.
H4905-12	12'	63 lbs.
H4905-14	14'	70 lbs.
H4905-16	16'	76 lbs.
H4905-18	18'	85 lbs.
H4905-20	20'	98 lbs.

SPLICED LADDERS

Spliced Ladders can be combined to reach lengths up to 32 feet. They have 2-1/2" rails and top sections are provided with 8" hooks complete with chains.



2 RAIL SPLICED LADDERS

PART #	DESCRIPTION	WEIGHT
C402-0482	10' Top section	44 lbs.
C402-0402	12' Top section	48 lbs.
C402-0404	14' Top section	52 lbs.
C402-0407	16' Top section	56 lbs.
C402-0411	20' Top section	64 lbs.
T402-0423	10' Middle section	44 lbs.
C402-0418	8' Bottom section	28 lbs.
C402-0421	10' Bottom section	32 lbs.
C402-0422	12' Bottom section	36 lbs.

3 RAIL SPLICED LADDERS

PART #	DESCRIPTION	WEIGHT
C402-0119	20' Straight ladder	100 lbs.
C402-0512	8' Bottom section	43 lbs.
C402-0513	12' Bottom section	52 lbs.
C402-0514	12' Top section	62 lbs.

EPOXIGLAS® INSULATED PLATFORMS

Insulated Platforms feature 12" of clear insulation provided by two 2" diameter poles connecting the platform to the mounting bracket. Order mounting brackets, tripods or railings separately.



Shown with optional pivot base and tripod.

TRIPODS & RAILINGS

PART #	DESCRIPTION	WEIGHT
H4964	Tripod for 4' insulated platform	9 lbs.
C402-1055	Railing for 4' insulated platform	13 lbs.
C402-0023	Railing for all 6' platforms	15 lbs.
C402-0024	Railing for all 8' platforms	17 lbs.
PSC402-1489	Personal fall restraint bracket	10 lbs.

INSULATED PLATFORM BOARDS

PART #	LENGTH	WEIGHT
C402-1042	4'	49 lbs.
C402-1043	6'	56 lbs.
C402-1079	8'	60 lbs.

PLATFORM MOUNTING BRACKETS

PART #	DESCRIPTION	WEIGHT
M4901-10W	Fixed pole mount	9 lbs.
M4901-21	Fixed tower mount	10 lbs.
C402-1164	Pivot base for 42" and 4' platforms	28 lbs.
C402-1173	Pivot base for 6' & 8' platforms	29 lbs.

FIBERGLASS EXTENSION ARMS



H4800-72

ROUND EPOXYGLAS® EXTENSION ARMS

Designed for use on voltages up to 15kV. They can also be used on voltages up to 34.5kV by fitting the wire holders with an insulator. The maximum vertical load is 150 per wire holder lbs. except the C400-1310 which has a 300 lbs. rating.

PART #	DIMENSIONS	WIRE HOLDERS	CROSSARM SIZE	WEIGHT
H4800-60	2-1/2" x 5'	1	3-3/4" x 4-3/4"	11.5 lbs.
H4800-72	2-1/2" x 6'	2	3-3/4" x 4-3/4"	13 lbs.
T403-2417	2-1/2" x 6'	2	3-3/4" x 4-3/4" & 6" x 6"	15 lbs.
C400-1310	3" x 6'	2	3-3/4" x 4-3/4" & 6" x 6"	24 lbs.



7545

SUPER "U" EXTENSION ARMS

The "U" shaped profile gives these arms a load rating of 200 lbs. per wire holder. These arms are furnished with an insulator on each wire holder giving them a 35kV rating.

PART #	WIRE HOLDERS	CROSSARM SIZE	WEIGHT
7545	2	4-1/4" x 6-3/4"	18.8 lbs.
7547	1	4-1/4" x 6-3/4"	15.4 lbs.

AB CHANCE HOT ARM INSULATOR

PART #
M4805-7



STEEL WIRE BASKETS

Ideal for storing and shipping all types of fiberglass hot arms or any other equipment. The front side of these stackable baskets folds down for easier loading and unloading of equipment.

*Order DNS-10 for 5' hot arms and DNS-11 for 6' hot arms

PART #	WIDTH	DEPTH	HEIGHT
DNS-7	47"	40"	36"
DNS-10*	67"	44"	41"
DNS-11*	79"	43"	36"
DNS-12	60"	38"	49"



7545 extension arms in TES10 wire basket

FIBERGLASS CONDUCTOR SUPPORTS & GINS

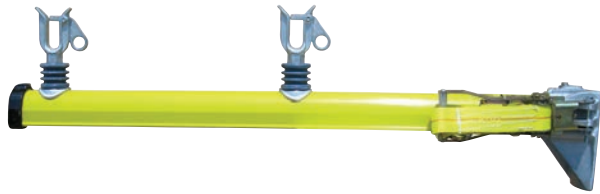

SUPER "U" SUPPORT ARMS

Designed for reconducting and maintenance of line voltages up to 34.5kV. They have a load rating of 200 lbs. per wire holder and a 44" long ratcheting nylon strap binder.

PART #	WIRE HOLDERS	LENGTH	WEIGHT
5045	1	34-3/4"	14.3 lbs.
5047	2	49-7/8"	18 lbs.



ROUND CONDUCTOR SUPPORT ARMS

Insulated temporary conductor supports to hold energized distribution conductors up to 15kV. For higher voltages, use M4805-7 insulator. The working load is 150 lbs. per wire holder on the T400-1939 and 200 lbs. on the T400-1940.

PART #	WIRE HOLDERS	LENGTH	WEIGHT
T400-1940	1	30"	14 lbs.
T400-1939	2	48"	18 lbs.



CROSSARM SLING

Made of 12 plies of nylon laminated together with neoprene. Resistant to oil, creosote and moisture. 23-1/4" long.

PART #
5607



TRANSFORMER GIN

The eye of this iron gin stands 10-5/8" off the pole. It comes with a ratcheting strap binder. WLL 1,900 lbs.

PART #
5800-5



TRANSFORMER GIN

Fits 3-1/2" x 4-1/2" up to 4-3/4" x 5-3/4" crossarms. 44" overall length.

PART #	LOAD RATING
H20	750 lbs.



TRANSFORMER GIN

Ratcheting strap type fits most structures and has a 5" extended base. 26" overall length.

PART #	LOAD RATING
T400-1938	2,000 lbs.

UNIVERSAL ATTACHMENTS



DISCONNECT HEAD

PART #

TEUD1



TREE & ROPE HOOK

PART #

M4455-80



SHOTGUN ADAPTER

PART #

M1867



DOUBLE HEADER

PART #

DH-1



HAMMER

PART #

M4455-85



BOLT HEAD WRENCH

PART #

M4455-88



COTTER KEY PULLER

PART #

M4455-96



COTTER KEY HOLDER

PART #

M4455-103



**FIXED PRONG
TIE STICK HEAD**

PART #

M4455-17



**FIXED BLADE
TIE STICK HEAD**

PART #

M4455-40



**ROTARY PRONG
TIE STICK HEAD**

PART #

M4455-69



**ROTARY BLADE
TIE STICK HEAD**

PART #

M4455-70



SPIRAL DISCONNECT

PART #

M4455-79

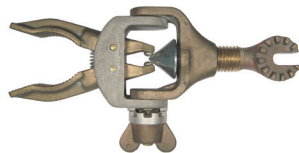

ALL-ANGLE PLIERS

PART #

C403-0177



TREE & ROPE HOOK

PART #

M4455-80



COTTER KEY TOOL

PART #

M4455-82

UNIVERSAL ATTACHMENTS



**COTTER KEY
REPLACER**

PART #
C403-0005



**COTTER KEY
TOOL**

PART #
C403-0006



**TIE WIRE
CLAW**

PART #
C403-1416



**UTILITY
HEAD**

PART #
C403-1417



**BALL SOCKET
ADJUSTER**

PART #
C403-0126



**PIN
HOLDER**

PART #
M4455-2



**RATCHET
WRENCH**

PART #
M4455-6



**COTTER KEY
REMOVER**

PART #
M4455-12



**LOCATING
PIN**

PART #
M4455-15



**FOLDING
RULE**

PART #
M4455-16



**COTTER KEY
PUSHER**

PART #
M4455-19



**BALL SOCKET
ADJUSTER**

PART #
M4455-22



**SCREW
DRIVER**

PART #
M4455-28



**CLEAR VISION
MIRROR**

PART #
M4455-38



**FLEX HEAD
WRENCH**

PART #
M4455-46



**SKINNING
KNIFE**

PART #
M4455-50

UNIVERSAL ATTACHMENTS



CUTOUT TOOL

This tool holds, installs and removes most brands of 100 amp fuse holders. The disconnect prong opens and closes cutouts.

PART #
PSC403-3484

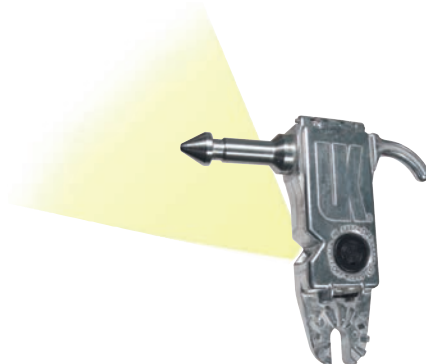

LIGHTED DISCONNECT HEAD

With a built-in LED light, this tool is perfect for dark or unlighted areas and night operations. Includes 3 AAA batteries.

PART #
LIT FINGER

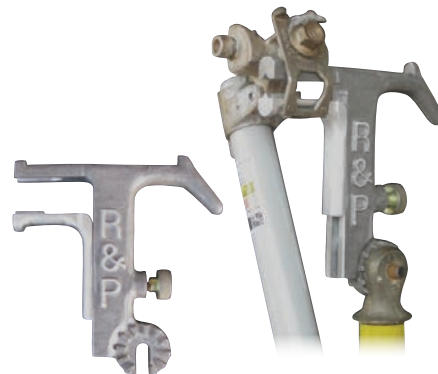

SAFETY FINGER

A safety device for installing and removing cutout fuse barrels. The spring-loaded design holds the fuse barrel in place and prevents it from falling. Fits standard 100 amp cutout fuse barrels.

PART #
TESF1



CUTOUT FUSE PULLER

Easily removes and installs the fuse tube from the cutout body.

PART #	AMPERAGE
GRAB-IT-1	100



HOT RODDER TOOL

PART #	LOOP
C403-1071	1-3/4"



FUSE PULLER

PART #	SIZE
M4455-77	1/2" - 1-1/2"



ARMOR ROD TOOL

PART #
10-096



ADJUSTABLE INSULATOR FORK

Designed to grasp 9" and 10" disk insulators.

PART #	OPENING
T4031101	2-1/4" to 3"
M4455-67	3" to 4-1/2"

UNIVERSAL ATTACHMENTS



BULB BITER & SUPER BULB BITER

These bulb changers are made of 100% rubber and will not scratch or shatter bulbs. They fit a variety of large utility bulbs.

PART #	DESCRIPTION
TEBB	Accepts 70 to 150 Watt sodium, 100 & 175 Watt mercury, and 175 & 250 Watt metal halide
TEBB-S	Accepts 400 Watt mercury and 400 Watt metal halide bulbs

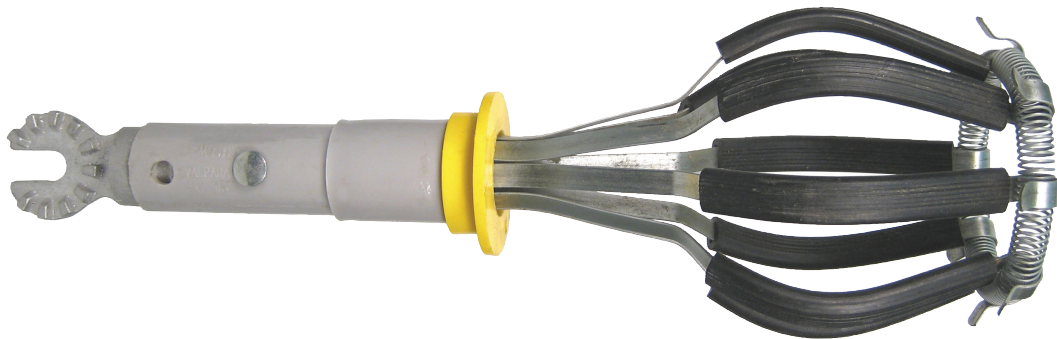

LAMP CHANGER

PART #	DESCRIPTION
151-ACA	100-200 Watt bulbs
152-C	300-500 Watt bulbs
153-C	750-1500 Watt bulbs

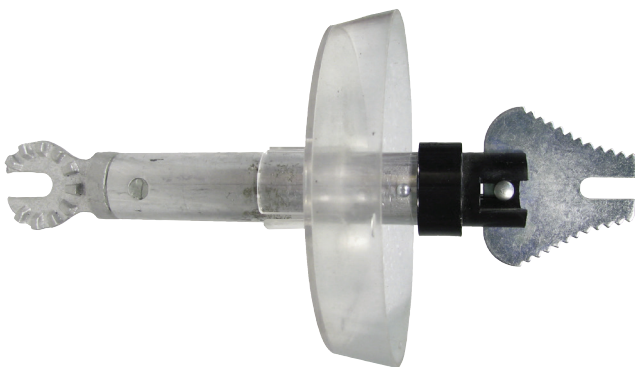

BROKEN LAMP BASE REMOVER

PART #
200-A



PHOTO CELL TESTER

PART #
UH-016

UNIVERSAL ATTACHMENTS



BOLT-THRU WRENCH

For 5/8" hardware.

PART #
M4455-89



INSULATED RATCHET WRENCH

This 9" polymer wrench provides protection against electrical shock up to 1,000 VAC.

PART #	DRIVE
TE06IRW-U	3/8"
TE08IRW-U	1/2"



FULL RANGE CONDUCTOR GAGE

This lightweight aluminum gauge measures conductors from #6 ACSR to 954 kcmil ACSR quickly and easily. Supplied with a protective storage case.

PART #
PSC4032956

CONDUCTOR RANGE		
CONDUCTOR	MINIMUM	MAXIMUM
Copper	#4	300 kcmil
ACSR	#6	954 kcmil
AAAC	20 mm ²	400 mm ²
AASC/ASC	#4	477 kcmil

METERS & TESTERS



REGULATOR NEUTRAL DETECTOR

The RND ensures that the operator has the regulator in its neutral position prior to disconnecting the regulator from the circuit to neutral. Works with step type and induction type regulators. 0 - 2000 volt range is shown in one volt increments. Works with all regulators up to and including 34.5kV systems.

PART #
6709-1



CABLE LENGTH METER

Push button selection of copper or aluminum measures both cable length and resistance without removing it from the spool. Measures cable length from 15 ft. to 100,000 ft.

PART #
CLM-1000



GROUND RESISTANCE TESTER

For a loop grounding system, the operator can measure the ground resistance and test for continuity without having to break down the grounding wire, or use auxiliary electrodes. (sometimes referred to as stakes)

PART #	DESCRIPTION
GRT-1000	1000 Ω tester



ROTATION METER

Can be used on 3-phase, 3 wire, circuits from 60V to 600V and on 25 to 60 cycle current.

PART #	DESCRIPTION
44030	Meter
44050	Carrying case



"WIGGY" SOLENOID TESTER

Locates blown fuses, grounds and system leaks. Works on voltages from 120V to 600V in both AC & DC current.

PART #
TE72-6790



ELECTRONIC VOLTAGE TESTER

Solid state design is safer than solenoid testers. Low impedance to reduce false readings. Indicates voltage without battery. Voltage indicated by lights, vibration and tone.

PART #
ET-100

METERS

V-WATCH PERSONAL VOLTAGE DETECTOR

Worn on the outside of clothing at mid-torso, this voltage detector alerts the user to the presence of electrical fields or energized equipment. Warning distance is about 7 feet from a 4kV AC conductor. Auto shut-off when the pouch is closed.



PART #	KIT INCLUDES
VW-20H-K	V-Watch with C-10 carry case, and VW-K-bag
VW-20HFR-K	V-Watch with C-10 flame resistant carry case, and VW-K-bag



4556

AV METER

2500 Shotgun adapter Included with meter.

PART #	VOLTAGE SETTINGS (PHASE TO PHASE)	
4556	240V, 4.2kV, 15kV, 25kV, 35kV, 69kV, 115kV, 230kV	
4667	240V, 4.2kV, 35kV, 69kV, 115kV, 230kV, 345kV, 500kV	
4769	OVERHEAD	4.2kV, 15kV, 25kV, 35kV, 46kV, 69kV
	UNDERGROUND	15kV, 25kV, 35kV

AV METER

Up to 12 available voltage settings that are completely customizable by the customer. Meter assembly is over voltage protected. Incidental direct contact will not damage the unit. Super bright LEDs and ultra loud horn guarantees operator seeing & hearing unit. Built in test position is standard for all units. May also be used as a direct contact voltage detector. Standard universal/grip all adapter is included with every unit.



PART #
AV METER

PROXIMITY VOLTAGE DETECTOR

A non-contact tester with nine standard voltage ranges from 120V to 500kV. It gives an audible and visual indication and can detect voltage on elbow test points at the 120V setting. Can be charged quickly from a 115 VAC or 12 VDC outlet.



PART #	DESCRIPTION
PRX-69D	For voltages to 69kV
PRX-500	For voltages to 500kV

DIGITAL VOLTAGE INDICATOR

Reads voltages from 0.1 to 500kV on overhead and underground systems. There are no switches or settings to be made. Kit includes 2" hook probe, 6" hook probe, underground bushing probe for 15kV, 25kV & 35kV, proof tester for voltage indicator and storage case.



PART #	DESCRIPTION
DVI-100/K02	For voltages to 100kV
DVI-500/K02	For voltages to 500kV

METERS



Digital model shown

SUPER BEAST

Capable of verifying the installation of new service connections to ensure proper voltage supply. Indicates problems on secondary service. Detects open neutral quickly and accurately. Isolates and identifies overhead or underground complaints on utility side. Verifies condition of secondary conductors and associated connections. Available in analog and digital models.

Kit includes meter base adapter and padded carrying bag.

PART #	DESCRIPTION
AISB-A-C	Analog model
AISB-D-C	Digital model



MEGA BEAST

3 Wire, 120 volt service conductor tester. The Mega Beast provides fused and circuit breaker safety. In 20 Amp increments you can apply a 80 Amp load to detect most elusive secondary problems. Detects open neutrals quickly and accurately.

PART #
AIMB

METERS



ST500

See page 421 for application notes.



ST800

SERVICE TESTER

Identify bad conductor(s) from the transformer to the meter base. Indicate integrity of neutral conductor to prevent excessive house ground currents. Locate both hot legs and neutral at the pedestal and/or transformer blocks. Locate bad connectors on overhead spans. Identify de-energized URD primary cable in a manhole or ditch.

PART #	DESCRIPTION
ST500	500A service tester
ST800	800A service tester

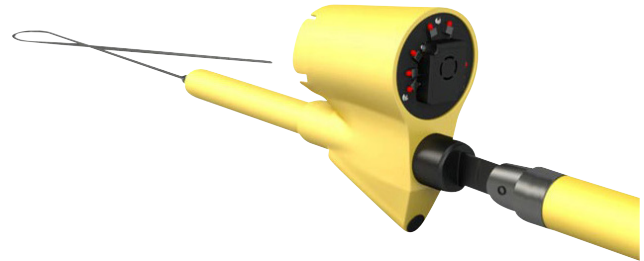

VOLTAGE BREAK INDICATOR

VBI-15 voltage break indicator is activated when voltage levels drop below 2.5kV line to ground (4kV phase to phase)
 The VBI-15 is used as a silent sentinel, the 112db horn and array of super bright led's are activated when the line becomes de-energized. The absence of voltage detector is designed to be used on single phase nominal 7.2kV - 20kV systems line to ground.
 Overload protected to 115kV.

PART #
VBI-15



QUICK CHECK LOAD DEVICE

Designed for safely applying a load to "non-registration" meters to determine if the disk turns. Features include resistance coil load with fan. Red and black probes on 42" leads. Usable on 120 V and 240 V. Provides 300 Watts at 120V and 1250 Watts at 240 V.
 Lightweight and rugged and is protected by a thermal overload switch.

PART #	DESCRIPTION
1000-SP2407	120 - 240 V unit
1000-SP3696	480 V unit

CLAMP METERS

All models have True RMS AC voltage and current measurements. Models with DC current capability can measure AC, DC, and AC/DC voltage and current. AmpTip™ design gives accurate current measurements on small wires carrying up to 60 amps.

All models include batteries, carrying case and test leads.



CMT-80

CMT-90

CM-660

CM-1360

CMI-600

CMI-1000

CLAMP METER MODEL

FEATURES	CMT-80	CMT-90	CM-660	CM-1360	CMI-600	CMI-1000
Jaw Opening	1.06"	1.34"	1.18"	2"	1.38"	2"
True RMS	AC	AC	AC	AC	AC+DC	AC+DC
Phase Sequence Test					✓	✓
Motor Rotation Test					✓	✓
AmpTip™			✓	✓	✓	✓
Backlight Display		✓		✓	✓	✓
Automatic Power Off	✓	✓	✓	✓	✓	✓
Flashlight				✓		✓

RANGE SPECIFICATIONS

AC Amps	400	600	600	1000	600	1000
DC Amps					600	1000
AC Volts	600	1000	600	1000	600	1000
DC Volts	600	1000	600	1000	600	1000
Resistance	10 kΩ	10 kΩ	60 kΩ	60 kΩ	60 kΩ	60 kΩ
Measurement Category	CAT IV 600V CATIII 1000V	CATIII 600V	CAT IV 300V CATIII 600V	CAT IV 600V CATIII 1000V	CAT IV 300V CATIII 600V	CAT IV 600V CATIII 1000V

MULTIMETERS

These digital multimeters have a backlit display, auto/manual ranging capabilities. Backed by a limited lifetime warranty, you can measure, AC/DC voltage and current, resistance, frequency and more. All models include batteries, test leads and a protective boot.



DM-45



DM-210A



DM-510A



DM-820A



DM-65



DM-810A

MULTIMETER MODEL

FEATURES	DM-45	DM-65	DM-210A	DM-510A	DM-810A	DM-820A
True RMS				✓	✓	✓
Auto Shut Off	✓	✓	✓	✓		✓
Temperature Measurement			✓	✓		
Non Contact Voltage Detection			✓	✓		✓

RANGE SPECIFICATIONS

AC Volts	600	1000	1000	1000	1000	1000
DC Volts	600	1000	1000	1000	1000	1000
AC Amps	10	10	8	8	10	10
DC Amps	10	10	8	8	10	10
Resistance	40 MΩ	60 MΩ	60 MΩ	60 MΩ	60 MΩ	60 MΩ
Measurement Category	CAT III 600V	CAT IV 600V CAT III 1000V	CAT IV 300V CAT III 600V CAT II 1000V	CAT IV 300V CAT III 600V CAT II 1000V	CAT IV 1000V	CAT IV 1000V

VOLTAGE TESTERS

DIGITAL VOLTAGE DETECTOR

This Digital Voltage Detector was designed for easily indicating voltages up to 999kV. Featuring a large LED display with black sunscreen, this unit can be read at distances of up to 50'. Universal Adapter included.

PART #	RANGE SETTINGS
VD1000	URD 0-99.9kV, OH 0-99.9kV and OHT 0-999kV



VD1000



VD1000 Kit

DISTRIBUTION ANALOG VOLTAGE DETECTOR

Detects 0-40kV line to ground (0-69kV phase to phase). Easy to read analog scale. Detect voltage from the ground on bare overhead lines when hand held. Test secondary voltage on bare or insulated cables. Test capacitive test points. The detector indicates line to ground values for nominal or induced voltages. The 5-position selector switch is calibrated for height above ground to compensate for a capacitive coupling effect. Shielded to minimize stray field interference. For your safety, the detector includes overload protection up to 500kV. Internal backlight available for night use. Kit includes meter, straight probe, shepherd hook, universal adapter and case.

PART #	DESCRIPTION
VDA040C	Capacitive test capability
VDA040P	Proximity test capability



VDA040C



VDA040C back



VDA040C kit

TRANSMISSION ANALOG VOLTAGE DETECTOR

Widest and highest voltage range available in a single voltage detector. 2.4kV - 450kV line to ground voltage range. For overhead and URD applications. Meter is passive, battery is only required for the test position. Meter is designed to read approximate nominal or induced voltage line to ground. Easy-to-use detector requires no voltage scale selectors or multipliers. Model with the "H" suffix comes with the hold and backlight feature. Kit includes meter, straight probe, shepherd hook, universal adapter and case.

PART #	DESCRIPTION
VDA0300	2.4kV - 300kV tester (4kV - 500kV phase to phase)
VDAH300	2.4kV - 300kV tester with hold and backlight (4kV - 500kV phase to phase)
VDA0450	2.4kV - 450kV tester (4kV - 765kV phase to phase)
VDAH450	2.4kV - 450kV tester with hold and backlight (4kV - 765kV phase to phase)



VDA300



VDA300 back



VDA300 kit

VOLTAGE TESTERS



AUTO-RANGING VOLTAGE INDICATOR

The C403-3374 begins detecting at 480 Volts and holds displays at 600V, 4kV, 15kV, 25kV, 35kV and 69kV. The C403-3375 begins detecting at 69kV and holds displays at 69kV, 11kV, 161kV, 230kV, 345kV, and 500kV. Kit includes the tester, shepherd hook and storage case. Order straight probe, bushing & elbow adapters separately for underground testing.

PART #	RANGE
C403-3374	600V - 69kV
C403-3375	69kV - 500kV



AUTO-RANGING VOLTAGE INDICATOR

When the probe is brought into contact with the conductor. It automatically begins detecting at approximately 100V and holds the display of one of these phase-to-phase voltage classes: 600 V, 4kV, 15kV, 25kV, 35kV, 69kV, 115kV, 161kV, 230kV, 345kV or 500kV. The audible signal begins as a slow beeping that becomes faster as the reading is increased.

Kit includes tester, shepherd hook and storage case.

PART #	RANGE
PSC403-2915	600V - 500kV



MULTI-RANGE VOLTAGE TESTER

This unit tests overhead systems from 1kV to 40kV and URD elbow test points. This kit includes the tester, shepherd hook, straight probe and storage case.

PART #	RANGE
C403-0979	1kV - 40kV
C403-1029	16kV - 161kV
C403-1140	69kV - 600kV



MULTI-RANGE VOLTAGE TESTER

This unit tests overhead & underground voltages from 5kV through 40kV. Kit includes tester, shepherd hook & straight probe, bushing adapter, elbow adapter and case.

PART #
T403-2271

SPECIALTY METERS



STEP AND TOUCH MONITOR KIT

This instrument monitors and alarms "Step and Touch" potential caused by ground potential rise. The SNT can enhance the safety of transmission line crews. The SNT kit includes two hot-stick compatible probe clamps.

PART #
SNT-A020



HIGH VOLTAGE DIGITAL AMMETER

Digital ammeter designed for taking AC current measurements up to 2000 amps, 25-500Hz. The HVA can be used on system voltages up to 500kV. The large, LED display allows real time monitoring of current from telescoping hotsticks.

The HVA-2000 will store the last 4 readings.

PART #	VOLTAGE	CURRENT	WEIGHT
HVA-2000	500kV	2000A	1.8 lbs.



8-020XT



8-020XT PLUS

AMPSTICK

PART #	8-020XT	8-022	8-024	8-020XT PLUS	8-022 PLUS	8-023 PLUS	8-024 PLUS
SPECIFICATIONS							
WEIGHT	2.15 lbs.	2.15 lbs.	2.15 lbs.	2.15 lbs.	3.78 lbs.	3.78 lbs.	3.78 lbs.
VOLTAGE	0-500kV	0-69kV	0-400kV	0-500kV	0-69kV	0-69kV	0-400kV
CURRENT	1-5000A	1-2000A	1-2000A	1-5000A	1-2000A	1-5000A	1-2000A
SENSOR OPENING	Standard	Wide Jaw	Wide Jaw	Standard	Wide Jaw	Wide Jaw	Wide Jaw
OPENING WIDTH	2.5"	3.86"	3.86"	2.5"	3.86"	3.86"	3.86"

PHASING STICKS



DIGITAL PHASING TESTER

This 0-40kV (up to 240kV with extension resistors) meter has a large easy to read display with Analog Bar Graph, Featuring 3 modes of operation and a lighted background display for low light conditions. The display automatically adjusts display if extension resistors are used. When in Hi-Pot mode for testing URD cables, the analog bar graph marks the peak voltage, 4kV while the cable is being charged. Kit includes meter, conductor hooks, batteries, case and instructions.

PART #	DESCRIPTION
6702	0 - 40kV digital volt meter



6702-1



6702-2



6702-3



6703

ACCESSORIES

PART #	DESCRIPTION
6703	Pair of extension resistors
6702-1	One 15/25kV load break bushing adapter
6702-2	One D.C. Hi-Pot adapter for up to 35kV
6702-3	One 35kV load break bushing adapter

PHASING STICKS



ANALOG PHASING TESTERS

Phasing Testers easily determine phase relationships and approximate voltage, line-to-line or line-to-ground. The probe fittings couple with a high-impedance component encased in each pole. To complete the test circuit, a 22 foot length of insulated flexible cable stores on the reel affixed to one pole and connects to the voltmeter on the other pole.

PART #	DESCRIPTION
H1876	16kV tester kit*
H1876-1	16kV tester, case, and manual
T403-2261	25kV tester kit*
H18767	40kV tester, case, and manual

* Kit includes: (2) 6' x 1-1/4" diameter epoxiglas® universal handles, storage bag, tester, hook probes, case and instruction manual.



T403-0856



C403-1762



T403-0857



H1876-4

ACCESSORIES

PART #	DESCRIPTION
T403-0857	15kV 25kV, & 35kV bushing adapter
T403-0856	Elbow adapter
C403-1762	Hi-Pot adapter
H1876-4	Pair of 48kV extension resistors
H1876-2	Pair of 80kV extension resistors

PHASING STICKS



ANALOG PHASING METER

Can be used as a stand-alone voltage detector without the second probe. A conventional phasing meter both overhead and URD applications. Phase capacitive test points. A large easy to read analog meter. Meter housing is completely shielded to minimize stray field indications. Each probe is impact and water resistant. Meter is stored in a highly durable padded carrying case. Kit includes tool, interconnect cable, universal adapters, straight probe & shepherd's hook.

PART #	RANGE
81280	0 - 25kV
83280	0 - 35kV



DIGITAL PHASING METER

Completely shielded interconnect cable (insulated 35kV to ground), that does not have to be held off of grounded or live objects for fear of shock or interfering with the reading. Multiple ranges 2kV through 50kV depending on model. Interconnect cable lengths up to 100 ft. The most accurate high voltage meter available, with accuracy to +/- 1%.

Extension resistors available for voltages up to 75kV. Kit includes tool, interconnect cable, universal adapters, straight probe & shepherd's hook.

PART #	RANGE
PD25	0 - 25kV
PD35	0 - 35kV
PD50	0 - 50kV



CORDLESS PHASING TESTER

The meter probe features a large easy-to-read digital display with backlight. Cordless phasing tool direct contact from 120V - 69kV, distribution systems. Cordless phasing tool (degree position only) non-contact from 69kV - 800kV, transmission/substation systems. Automatically alerts user of a delta/wye transformation by an indicator light blinking. Operating range of 100 ft. Kit includes tool, interconnect cable, universal adapters, straight probe & shepherd's hook.

PART #
PD800W



GPS PHASING TOOL

Features absolute phase identification, mapping & tagging, transmission phasing, distribution phasing, secondary phasing, mobile substation phasing, phase sequence cw/ccw, urd and overhead capacitive test point phasing, all general phasing, flags delta/wye, wye/delta transformations, simultaneous use of multiple field units, usable from 120V to 765kV.

PART #
PHASING RANGER

UNDERGROUND UTILITY LOCATORS



IMPULSE PHASING TESTER

This unit can identify single or three conductor cables in vaults or trenches regardless of the outer covering. It is also used to identify phases within a three phase circuit and the grounded section of faulted street light circuits. 5" clamps included.

PART #

541001-30

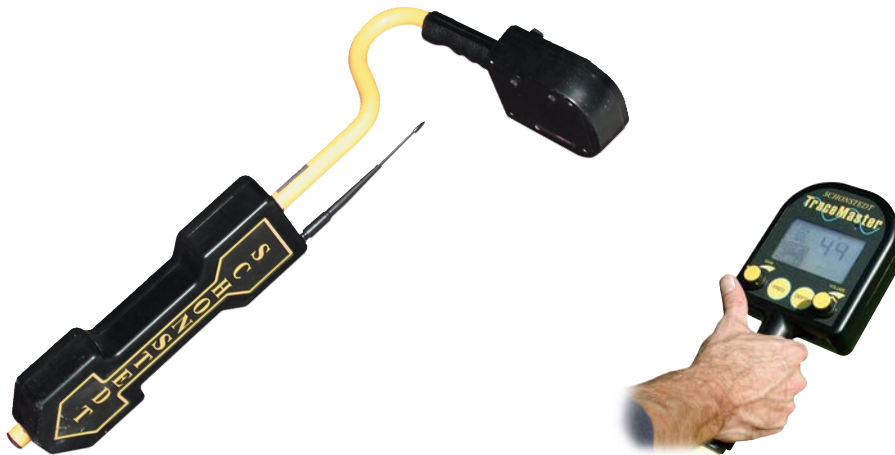

PIPE & CABLE LOCATOR

Easily locates buried telephone, cable TV, and fiber optic lines, AC power lines, water & gas pipes. Frequencies include: 575Hz, 8kHz, 82 kHz, and passive 50/60 cycle. The receiver operates on 8 AA batteries and the transmitter is rechargeable.

PART #

TMS-001-AF



PIPE & CABLE LOCATOR

This hand held locator is easy to use. The receiver extends from 17-1/2" to 27-3/4" inches for greater sensitivity. Operating Frequency: 512 Hz, 33 kHz and 82 kHz. Passive Detection: 50/60 Hz. Sonde Detection 512 Hz. Kit includes: XTPC-PLUS receiver, transmitter and accessories. Inductive Signal Clamp shown is optional.

PART #

XTPC-PLUS

UNDERGROUND UTILITY LOCATORS

The RYCOM 8869 & 8879 cable, pipe & fault locating kits offer advanced locating technology with simple operation. These locators provide any number of active frequency from 500Hz to 480kHz and multiple passive locate modes. Current measurement, current direction, and digital depth up to 30 feet help ensure accurate locates within congested environments. Transmitter features include automatic impedance matching, fault finding capability, multi frequency coupling induction modes and backlit digital displays.



UTILITY LOCATOR

Active Operating Frequencies: 815Hz, 8kHz, 33kHz, and 82kHz Passive operating 60Hz Signal application: Direct connection, coupler induction with optional coupler, transmitter induction. Peak/null, auto gain, left/right arrows. Manual gain control. Push-button depth. Multiple power settings up to 5 watts. Rechargeable or D-cell transmitter.

PART #	DESCRIPTION
8879V3-C	Line locator with coupler
8879V3-STAFF-C	Line locator with coupler & Rigid A Frame fault locator



UTILITY LOCATOR

Active Operating Frequencies: 815Hz, 8kHz, 33kHz, and 82kHz Passive operating 60Hz Signal application: Direct connection, coupler induction with optional coupler, transmitter induction. Peak/null, auto gain, left/right arrows. Manual gain control. Push button depth. Multiple power settings up to 3 watts. C-cell transmitter.

PART #	DESCRIPTION
8869V3-C	Line locator with coupler
8869V3-STAFF-C	Line locator with coupler & Rigid A Frame fault locator



CABLE & PIPE LOCATOR

Active Operating Frequencies: 815Hz, 8kHz, 33kHz, and 82kHz Passive operating 60Hz Signal Application: Direct connection, Coupler induction with optional coupler, Transmitter induction. Peak, left/right guidance modes. Manual gain control. Push-button depth. Multiple power settings up to 3 watts. C-cell transmitter.

PART #	DESCRIPTION
STICK	Line locator
STICK-STAFF	Line locator with Rigid A Frame fault locator



RIGID A FRAME FAULT LOCATOR

The Rigid A Frame is a fault finder that will work in coordination with the 8879, 8869 or the Stick transmitters. This A frame is equipped with a digital screen built into the handle that provides arrows and signal strength pointing in the direction of the fault. This feature eliminates plugging the fault finder into the receiver making the fault finder much more user friendly.

PART #
001-00487-00



COLLAPSIBLE A FRAME FAULT LOCATOR

This collapsible A Frame fault finder will work with the 8879 or the 8869 locator units. After plugging the fault finder into the receiver, the direction of the fault will be indicated on the screen of the receiver.

PART #
001-00214-00

UNDERGROUND UTILITY LOCATORS

Additional locators and accessories are available to locate almost any underground utility.



FAULT LOCATOR WITH TRANSMITTER

The "Staff" is a stand alone directional fault finder that can locate faults up to 2 megohms. The A Frame has an LCD display of directional arrow, current strength & reference indicators. It stands 30" high and weighs only 3 lbs.

PART #
STAFF



4" MULTI FREQUENCY INDUCTION COUPLER

Used with 8kHz and above.

PART #
100-00398-00



001-00281-02

SONDE

Sondes are used to trace the path of non-metallic pipes.

PART #	DESCRIPTION
001-00281-00	For 512Hz receivers
001-00281-02	For 33kHz receivers



7" FLEXI COUPLER

Multi frequency coupler 8kHz and above.

PART #
100-00245-00

STANDARD ANCHOR INSTALLING TOOLS

Standard duty tools are used for installing anchors at torques up to 10,000 ft-lbs. The Kelly bar adapters and locking dogs come complete with nuts, bolts and pull pins.



630013



C303-0069HD



C303-0020



T303-0166



639001



C102-1583 C303-1064

STANDARD DUTY 10K KELLY BAR ADAPTERS

PART #	KELLY BAR SHAPE	KELLY BAR SIZE	WEIGHT
630013	Hex	2"	10 lbs.
630011HD	Hex	2-1/2"	18 lbs.
630012HD	Hex	2-5/8"	18 lbs.

LOCKING DOG ASSEMBLY

PART #	DESCRIPTION
C303-0069HD	Complete standard assembly

REPLACEMENT PARTS KIT

Kit includes all parts to replace both locking dogs.

PART #
C303-0070

8" DRIVE TOOL

PART #	DESCRIPTION
C303-0020	SS5 / SS15 / RR drive tool

BOLT CIRCLE ADAPTER

PART #	DESCRIPTION
T303-0166	5-1/4" Bolt circle with 1/2" bolt holes 7-5/8" bolt circle with 5/8" bolt holes

INSTALLATION TOOL FOR SS5/SS150

Each tool comes with bolts, nuts and lock washers.

PART #
639001

7' DRIVE END WRENCH

PART #	DESCRIPTION
C102-1583	Standard duty for 1-3/8" anchors
C303-1064	Standard duty for 1-1/2" anchors

EXTENSION WRENCH

For standard and hybrid drive-end wrenches.

PART #	DESCRIPTION
630027	3-1/2' Extension
630028	7' Extension

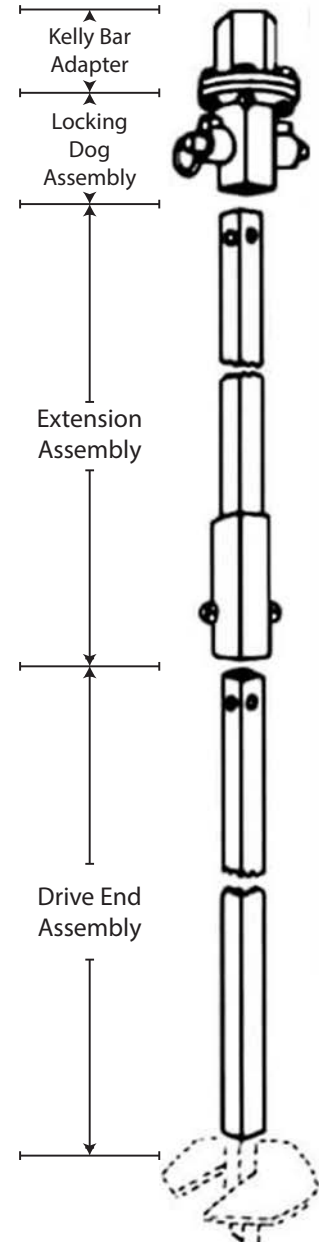

630028

TOUGH ONE® ANCHOR INSTALLING TOOLS

Tough One® series tools install anchors with up to 15,000 ft-lbs. of torque. The Kelly bar adapters and locking dogs come complete with nuts, bolts and pull pins.

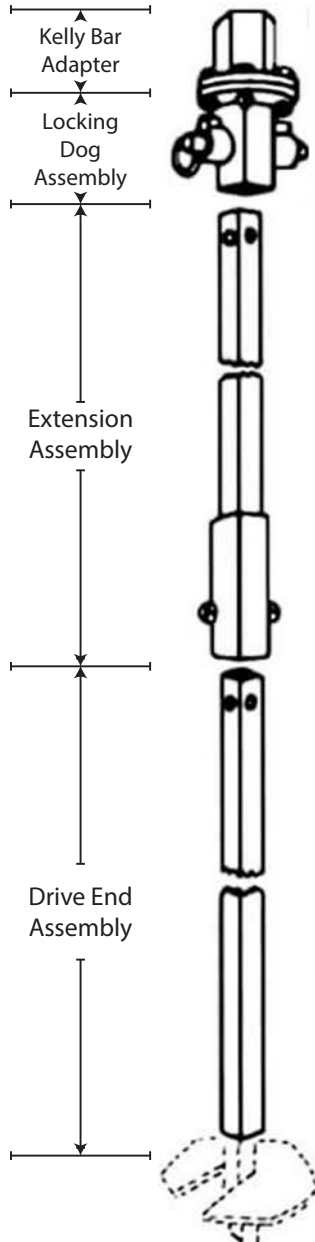

TOUGH ONE® 15K KELLY BAR ADAPTERS

PART #	KELLY BAR SHAPE	KELLY BAR SIZE	WEIGHT
C303-0936	Hex	2-1/2"	23 lbs.
C303-0937	Hex	2-5/8"	23 lbs.
C303-0940	Hex	3"	27 lbs.



C303-0936

TOUGH ONE® LOCKING DOG ASSEMBLY

PART #
C303-0981



C303-0981

REPLACEMENT PARTS KIT

Kit includes all parts to replace both locking dogs.

PART #
C303-1026

TOUGH ONE® 8" DRIVE TOOL

These tools slide into locking dog adapter and are retained by spring loaded dogs.

PART #	DESCRIPTION
C303-1035	SS5 / SS150 / RR drive tool
T303-1403	SS175 Drive tool
C303-1077	SS200 Drive tool



C303-1035

TOUGH ONE® SS ANCHOR INSTALLER

PART #	DESCRIPTION
C303-0195	SS175 Drive tool
C303-0201	SS200 Drive tool
C303-0202	SS225 Drive tool



C303-0195

TOUGH ONE® 7' DRIVE TOOL

PART #	DESCRIPTION
C303-0983	Tough one series for 1-1/2" anchors



C303-0983

TOUGH ONE® EXTENSION WRENCH

Extension attaches to drive-end wrench.

PART #	DESCRIPTION
C303-0987	3-1/2' Extension
C303-0988	7' Extension

ANCHOR TOOL ACCESSORIES



SHEAR PIN TORQUE LIMITER

PART #
C303-0044



**TORQUE INDICATOR
SHEAR PIN**

1 box has approximately 500 pins.

PART #
T303-1420



NO-WRENCH ANCHOR TOOL

PART #
E303-0255



DIGITAL WIRELESS TORQUE INDICATOR

Install screw anchors to a pre-determined torque value which gives a positive indication of anchor holding capacity. Also eliminates excessive torsional loading which can damage anchors and tooling during installation. Wireless display included.

PART #
C303-1689

Complete with U-Shaped bolt to secure SAT-85 in place.



The new SAT-85 allows you to fit the tool over the FH-205 pilot.



ANCHOR TOOL

This one-piece unit is used for installing anchors without having to remove the auger. This tool works in conjunction with any Pengo MD auger that is using the FH-205 pilot. Just slip the SAT-85 tool over the end of the FH-205 pilot and you are ready to install anchors.

PART #
SAT-85

MEDIUM DUTY CONSTRUCTION AUGERS

Made to the unique specifications of the different makes & models of pressure diggers & digger derricks. A variety of heads and teeth allow these augers to be used in different boring applications from dirt & gravel to frozen soil and hard rock.

SERIES MD-884

(OVERALL LENGTH 88" - FLIGHTING 40")

Standard Augers are available in diameters up to 48" and with flighting up to 60".

Custom size augers are also available.

PART #	POLE DIAMETER	C DIAMETER	# OF TEETH	WEIGHT
8MD-8840	8"	9-1/2"	2	140 lbs.
9MD-8840	9"	10-1/2"	2	154 lbs.
10MD-8840	10"	11-3/4"	2	166 lbs.
12MD-8840	12"	13-3/4"	4	197 lbs.
14MD-8840	14"	15-3/4"	4	215 lbs.
16MD-8840	16"	18"	4	244 lbs.
18MD-8840	18"	20"	6	287 lbs.
20MD-8840	20"	22"	6	294 lbs.
22MD-8840	22"	23-1/2"	6	327 lbs.
24MD-8840	24"	26"	7	369 lbs.

SERIES MD-10240

(OVERALL LENGTH 102" - FLIGHTING 40")

PART #	POLE DIAMETER	C DIAMETER	# OF TEETH	WEIGHT
8MD-10240	8"	9-1/2"	2	135 lbs.
9MD-10240	9"	10-1/2"	2	147 lbs.
10MD-10240	10"	11-3/4"	2	180 lbs.
12MD-10240	12"	13-3/4"	4	205 lbs.
14MD-10240	14"	15-3/4"	4	243 lbs.
16MD-10240	16"	18"	4	274 lbs.
18MD-10240	18"	20"	6	319 lbs.
20MD-10240	20"	22"	6	325 lbs.
22MD-10240	22"	23-1/2"	6	360 lbs.
24MD-10240	24"	26"	7	399 lbs.

AUGER TEETH

PART #	DESCRIPTION	APPLICATION
PG1650	Dirt	Ordinary digging
PG1652	Gage Tooth	Dirt
PG1656	Tungsten Carbide	High abrasion, frozen soil, low impact
PG1658	Carbide Gage	Highly abrasive soil, frozen ground
PG1650-HF	Hardfaced, 1 Side	Abrasive soil, impact
PG1650-HFF	Hardfaced, 2 Sides	Abrasive soil impact

Auger teeth for many other applications are available.

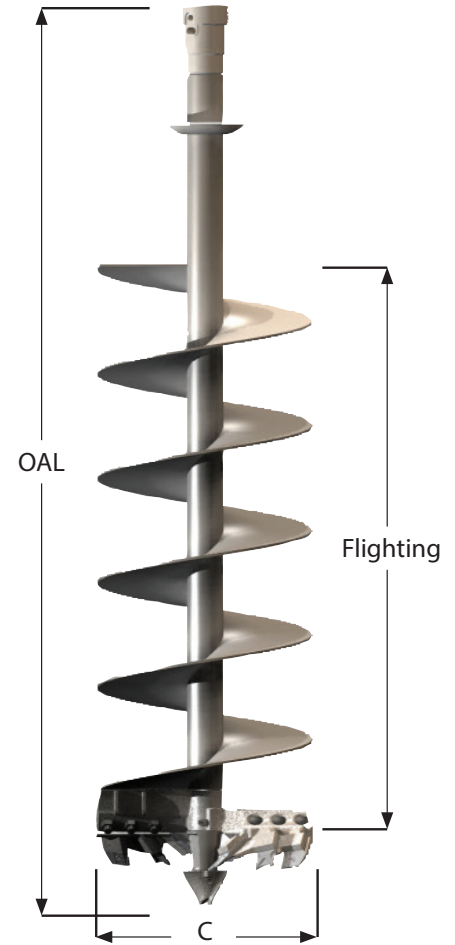

STANDARD HUB SIZES FOR MEDIUM DUTY AUGERS

2" Hex	2-1/4" Hex
2-1/4" Hex	2-5/8" Hex
2" Square	2-1/4" Square

Other sizes available upon request.



POLE PULLING & SETTING



CHAIN SLINGS

Made to order chain link slings.

With chain sizes from 7/32" to 1-1/4" and a variety of lengths and attachments, the combinations are virtually endless.

PART #	LENGTH	WLL	DESCRIPTION
CO06-4	4'	8,800 lbs.	3/8" grade 100
CO06-5	5'	8,800 lbs.	3/8" grade 100
CO06-6	6'	8,800 lbs.	3/8" grade 100
CO08-4	4'	15,000 lbs.	1/2" grade 100
CO08-5	5'	15,000 lbs.	1/2" grade 100
CO08-6	6'	15,000 lbs.	1/2" grade 100



CHAIN POLE SLINGS

Made with grade 100 chain and a sliding choker hook, these slings are ideal for handling large transmission poles.

PART #	LENGTH	WLL
CPS384	4'	7,100 lbs.
CPS385	5'	7,100 lbs.
CPS386	6'	7,100 lbs.



PULLING HOOK

PART #	OVERALL LENGTH
9055	10-1/2"
9062	15-1/2"



PULLING EYE

Adjusts from 1/2" to 1". WLL 6,000 lbs. Ultimate 30,000 lbs.

PART #
PE-1



HEAVY DUTY PULLING EYE

This pulling eye can be used for loads up to 15,000 lbs. Ultimate 60,000 lbs.

PART #	FITS ANCHOR ROD SIZE
HDPE-1000	1"
HDPE-1250	1-1/4"
HDPE-1500	1-1/2"
HDPE-1750	1-3/4"
HDPE-2000	2"
HDPE-2250	2-1/4"

POLE TONGS



40228



20

LIFTING TONGS

Proof-tested and certified for overhead lifting and are painted orange.

PART #	WEIGHT	AT 75° OPENING		AT 135° OPENING		AT 180° OPENING	
		OPENING	CAPACITY	OPENING	CAPACITY	OPENING	CAPACITY
40008	7.0 lbs.	3-1/2"	1,500 lbs.	12"	1,000 lbs.	16"	750 lbs.
40218	16.5 lbs.	6"	2,500 lbs.	17"	2,000 lbs.	20"	1,500 lbs.
40228	17.0 lbs.	7-1/2"	2,500 lbs.	20"	2,000 lbs.	25"	1,500 lbs.
40458	36.0 lbs.	8-1/2"	3,000 lbs.	27"	2,500 lbs.	32"	2,000 lbs.
40558	50.5 lbs.	12"	5,000 lbs.	32"	4,000 lbs.	36"	3,000 lbs.

HEAVY-DUTY LIFTING TONGS

Timbers or poles are held securely by the 1-1/4" triple saw tooth design and cannot slip under load.

PART #	WEIGHT	HEIGHT	OPENING	CAPACITY
20	20 lbs.	20-3/4"	11-1/2"	7,500 lbs.
30	30 lbs.	28-1/2"	16-3/4"	10,000 lbs.



THE MUD BUCKET

An easy to use tool that removes mud, gravel, water or other debris from deep holes. Great for cleaning holes prior to setting a pole. The bucket is made from 11 gauge cold rolled steel and can hold up to a gallon. The handles are made of durable, lightweight fiberglass that telescope from 6' to 12'.

PART #
TE683-H



818



818G

PIKE POLES

Used to help support utility poles during setting operations. The 2-1/2" handles are made of Fir wood and the points are made of malleable iron. Add "G" suffix for Point Guards.

PART #	LENGTH
818	12'
819	14'
820	16'
821	18'
822	20'

LONG HANDLE DIGGING TOOLS



LONG HANDLE DIGGING TOOLS

PEAVEY PART #	DESCRIPTION	OSHKOSH PART #
TE-015-096-0821	8' Heavy tamp bar	1055
TE-015-120-0823	10' Heavy tamp bar	1057
TE-015-144-0824	12' Heavy tamp bar	1058
TE-019-096-W801	8' Western pattern spoon	2024
TE-019-120-W803	10' Western pattern spoon	2026
TE-019-144-W804	12' Western pattern spoon	2027
TE-019-096-0811	8' Straight shovels 10" blade	2033
TE-019-120-0813	10' Straight shovels 10" blade	2035
TE-019-144-0814	12' Straight shovels 10" blade	2036
TE-015-096-OCED	8' Split handle post hole diggers	2050-8
TE-015-120-OCED	10' Split handle post hole diggers	2050-10
TE-015-144-OCED	12' Split handle post hole diggers	2050-12
TE-015-096-0903	8' Solid handle post hole digger	2051-8
TE-015-120-0905	10' Solid handle post hole digger	2051-10
TE-015-144-0907	12' Solid handle post hole digger	2051-12



FIBERGLASS DIGGING BAR

Round 1-1/4" x 8' bar with chisel and point.

PART #
TE795-HD-8



FROST BAR

1-1/8" x 8' Hex Bar with 2" chisel and pointed end.

PART #
280TE

POLE SETTING TOOLS



60" FIBERGLASS HANDLE CANT HOOK

These are non-rated tools favored by utility companies. 1-1/2" diameter handle. Grips 10" - 36" diameter logs.

PART #	HANDLE	HOOK SIZE
FCH-060	1-1/2" x 5'	10"



ALUMINUM HANDLE CANT HOOK

These cant hooks are built with a heavy-duty aluminum handle for extra strength in extreme applications.

PART #	HANDLE	HOOK SIZE
XCH-060	1-1/2" x 5'	10"
XMH-078	1-1/2" x 6-1/2'	13-1/2"



WOOD PEAVIES

PART #	HANDLE	HOOK #	HOOK SIZE
135	2-1/2" x 4-1/2'	479	8"
136	2-1/4" x 5'	479	8"
138	2-1/2" x 4-1/2'	480	9"
139	2-1/2" x 5'	480	9"



WOOD CANT HOOKS

PART #	HANDLE	HOOK #	HOOK SIZE
06250	2-1/2" x 4-1/2'	480	9"
206-4645	2-3/4" x 6'	4645	14-1/2"



FIBERGLASS HANDLE CANT HOOKS

Solid fiberglass handles and forged steel hooks for use on almost any size pole.

PART #	HANDLE	HOOK SIZE
HI48CHS-8	48"	8"
HI72CHS-8	72"	8"
HI48CHS-10	48"	10"
HI72CHS-10	72"	10"
HI48CHS-12	48"	12"
HI72CHS-12	72"	12"



POLE CRADLE

Provides an efficient way of lifting poles into position for framing. It measures 18" x 15" x 9" and weighs 23 lbs. It can handle poles with diameters up to 19".

PART #
4241

POLE SETTING TOOLS



Rubberized Non-Skid Grip

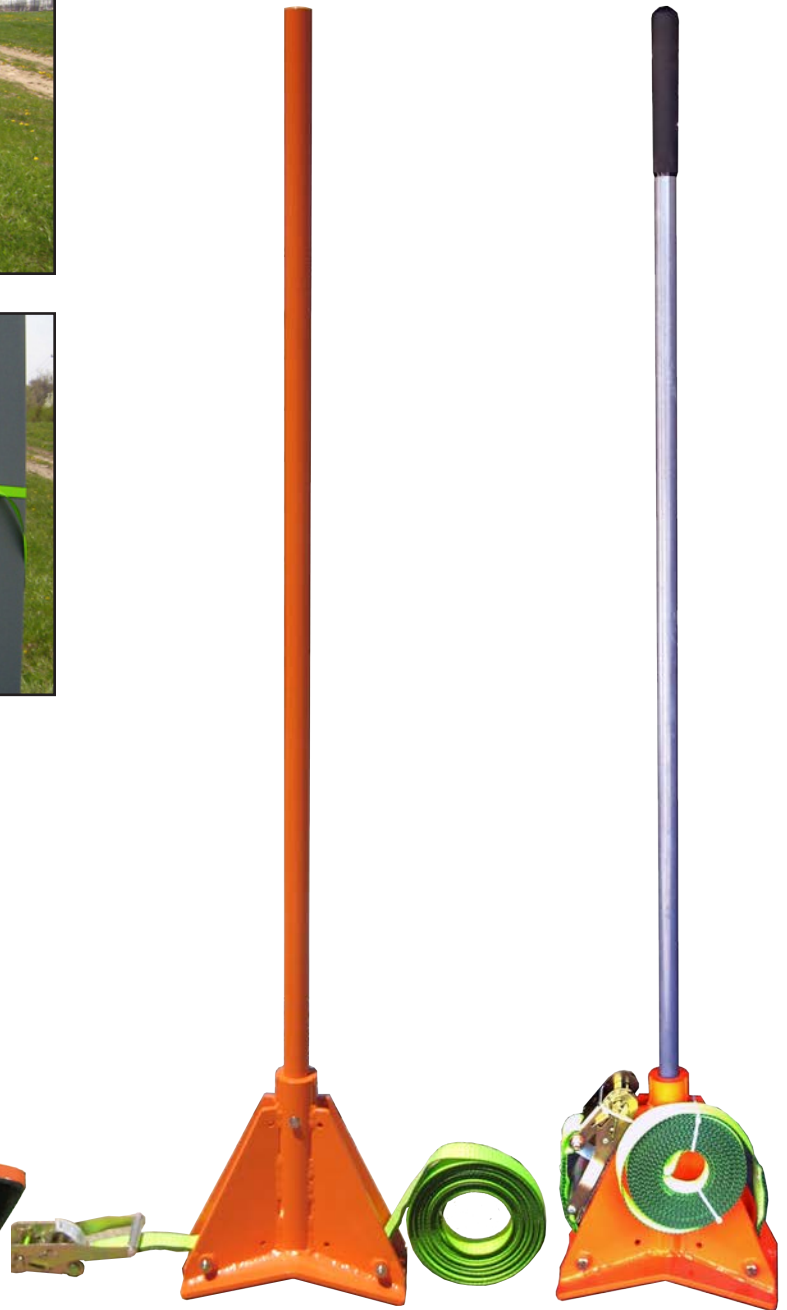

DNTPCH

DNTPCH-F

TRANSMISSION POLE CANT HOOK

The Transmission Pole Cant Hook with 30' Nylon Strap comes equipped with a 1-1/2" diameter handle. The lightweight aluminum head and the rubber texturized "V" face offer a superior grip that is designed to minimize any slip while operating.

Provides linemen with the extra torque and easy feel needed to get the job done efficiently and effectively.

PART #	HANDLE	LENGTH	WEIGHT
DNTPCH	Steel	75"	40 lbs.
DNTPCH-F	Fiberglass	75"	25 lbs.

FIBERGLASS SHOVELS & UTILITY PROBES



D-HANDLE FIBERGLASS SHOVELS

PART #	HANDLE LENGTH	BLADE
HISP2D	27"	Square point
HIRP14D	27"	Round point
HISS14D	27"	Drain spade

STRAIGHT HANDLE FIBERGLASS SHOVELS

PART #	HANDLE LENGTH	BLADE
HISP2L	47"	Square point
HIRP14L	47"	Round point
HISS14L	47"	Drain spade



MUD SHOVELS

Holes in the blade allow mud and clay to release effortlessly.

PART #	HANDLE LENGTH	BLADE
HIRPMSL	27"	Round point
HISPMSL	27"	Square point
HIRPMSD	27"	Round point
HISPMSD	27"	Square point

FIBERGLASS PROBES

PART #	LENGTH
HIUP-48	48"
HIUP-60	60"

POLE SETTING TOOLS



TWISTARP

Dirt sling used to hold the dirt removed from an auger to be used when backfilling around a newly installed pole. Also works well as a utility blanket keeping personnel and tools out of weeds, mud and snow or for transporting left over dirt, rock, sand, or wet cement.

PART #	SIZE	CAPACITY
6X6R	6' x 6'	4,000 lbs.
7X7R	7' x 7'	4,000 lbs.
8X8R	8' x 8'	5,000 lbs.
10X10R	10' x 10'	5,000 lbs.



THE DIRT SKIRT

10' x 10' dirt sling. The unique design of this tarp captures auger spoils and neatly fills the hole after setting a pole. It reduces time and labor and the risk of injury.

PART #
DIRT SKIRT



STAPLE STICKS

Keeps staples ready for use and helps prevent possible punctures to rubber gloves. Easy to use while wearing heavy gloves. Two loaded sticks hold enough staples to install a ground wire on most distribution poles.

PART #	SIZE
TESS2000	3/4" Wide slots
TESS2001	1" Wide slots



DRAW KNIVES

Used to shave and shape uneven areas of wooden poles. Handles are kiln dried Ash with a lacquer finish. The blades are cut from a solid bar of high carbon spring steel.

PART #	SIZE
49962	5"
49941	8"
49931	10"
49951	13"

POLE TAMPERS



H4802

H4802-3

HYDRAULIC POLE TAMPER

Makes quick work of setting poles, asphalt patching and general compacting. This model has the on/off valve on the whip hoses. The flow rate is 4-6 GPM with an operating pressure between 1,000 to 2,000 PSI and can provide 1,160 BPM at 5 GPM. The kidney shoe is standard.

PART #	LENGTH	WEIGHT
H4802	60"	23 lbs.

HYDRAULIC POLE TAMPER

Same as the H4802 but without the on/off valve on the hoses.

PART #	LENGTH	WEIGHT
H4802-6	60"	27 lbs.

HYDRAULIC POLE TAMPER

Similar to the above tools but with the on/off valve on the handle.

PART #	LENGTH	WEIGHT
H4802-3	72"	23 lbs.

HYDRAULIC POLE TAMPER

Ideal for soil compaction around utility poles. This model does not have an on/off valve, that function is controlled by the vehicle's hydraulic circuitry. It weighs 39 lbs. and is 66" long. The flow rate is 3-9 GPM and provides 1,600 BPM. The kidney shaped shoe is standard.

PART #	LENGTH	WEIGHT
TA54603	66"	39 lbs.

HYDRAULIC POLE TAMPER

Same as the TA54603 but with the on/off valve on the handle.

PART #	LENGTH	WEIGHT
TA54103	71"	39 lbs.

For hydraulic tampers that are field ready, complete with couplers and hose, add a "C" to the end of the part number.



TA54603-C



PNEUMATIC POLE TAMPERS

Used for compacting soil. These tools are 52" in length, weighs 37 lbs. and provides 670 BPM. The air inlet is 1/2" female NPT thread with pressure of 90 PSI.

PART #	DESCRIPTION
TE131-C	Kidney shaped shoe
TE131-R	3" Round shoe

POLE PULLERS



HYDRAULIC POLE PULLER

This unit has a maximum operating pressure of 2,800 PSI and a lifting force of 50,120 lbs. The kit comes complete with the cylinder, base plate, back plate, swivel chain hook assembly and 6' of 1/2" chain. Works great on concrete poles.

PART #
4001D

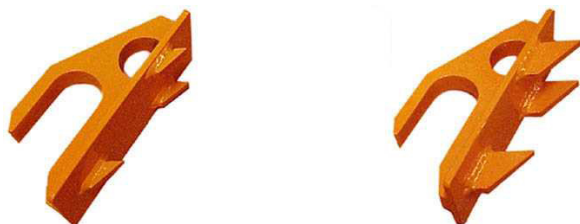

BACK PLATES FOR POLE PULLER

Sold separately.

Optional back plate prevents chain roll-up and slippage.

PART #	DESCRIPTION
4040B	Short tooth
4041B	Long tooth



POLE PULLER PAD

Engineered with the strength to take the full force of the pole-pulling, and the flexibility not to crack under soft ground conditions. 24" x 29".

PART #
HA0040



HYDRAULIC POLE PULLER

This puller operates on both open and closed-center systems with pressures from 300 - 2,800 PSI. It's lifting capacity is 56,000 lbs. with a 16.8" stroke. Two 5/8" x 6' proof-certified chain are included. The cylinder weighs 101 lbs. Combined weight with base & chain is 178 lbs. Required fittings are listed below.

PART #
H4910A

H4910A REQUIRED FITTINGS

PART #	DESCRIPTION
F011243	Nipple (2)
FF3718FP	Female coupler, 1/2" NPTF
FF3728FP	Male coupler, 1/2" NPTF



HYDRAULIC POWER UNIT

A completely portable gas powered hydraulic pump designed to compliment the 4001D Pole Puller. It produces 2,800 PSI and has a flow rate of 1.8 to 2.0 GPM. Weighs 92 lbs.

PART #
TC-1



TRANSFORMER DOLLY

Designed to maintain vertical positioning of the transformer preventing leakage. Equipped with low pressure turf tires, engineered with a standard trailer hub and sealed bearings and a third pilot wheel to allow 360° steering. The combination of the main wheel and third pilot wheel results in a extremely ergonomic design eliminating arm strain for the user.

MODEL	CAPACITY	SIZE (H x W x L)	WEIGHT
HA0075	950 lbs.	44-3/4" x 40" x 39"	365 lbs.



POLE DOLLY WITH ROLLER CRADLE

180 degree steering, Low-pressure turf tires. Supplied with a straight handle for easy movement. Constructed with high-yield strength steel in excess of 100,000 PSI. Assembled with wheel bearings and bronze steering bushings.

PART #	CAPACITY	SIZE (H X W X L)	WEIGHT
1025A	2,200 lbs.	27-1/4" x 32" x 23-1/4"	157 lbs.



ROLLER CRADLE ASSEMBLY

Attaches in just seconds. Provides ready transport for poles up to 2,200 pounds. Rollers are manufactured with ultra high molecular polyethylene.

PART #
1125A



TRANSFORMER LOAD DECK AND DOLLY

A safe and effective way to move equipment in tight areas. It measures 32" wide, 93" long and has a 3,000 lb capacity. Supplied with a "T" handle assembly and has (2) two-wheel steerable dollies with 180 degree steering load deck.

MODEL	CAPACITY	SIZE	LENGTH	WEIGHT
1030A	3,000 lbs.	24" x 32"	97"	365 lbs.



All pumps tools are pressure tested prior to shipment.

WATER PUMP

A submersible, centrifugal-type pump that requires no priming. The motor is a contaminant-tolerant gear motor uniquely designed for continuous high-speed operation. The motor drives the impeller directly, so there are no spindle bearings that require periodic lubrication or replacement.

PART #	OUTLET SIZE	CAPACITY	FLOW RANGE	WEIGHT
SM50	3" NPT / 3" Camlock	500 GPM	7-12 GPM	21 lbs.



WATER PUMP

The SM20 Water Pump is one of the lightest and most durable pumps available. Pumping 250 GPM at a 10 foot head and moving solids up to 5/16 of an inch makes it ideal for vaults and manholes.

PART #	OUTLET SIZE	CAPACITY	FLOW RANGE	WEIGHT
SM20	2-1/2" Discharge	250 GPM	4-9 GPM	13.7 lbs.



WATER PUMP

Ideal for vaults, manholes and more specifically in confined narrow openings. There is no recoil starting, priming or suction hose as with gas engine driven pumps. Pump can be run dry without damage.

PART #	OUTLET SIZE	CAPACITY	FLOW RANGE	WEIGHT
SM21	2-1/2" Discharge	300 GPM	4-9 GPM	20 lbs.



TRASH PUMP

The lightest, most efficient way to move large volumes of liquid with concentrations of solids up to 25% by volume. The urethane bowl is virtually indestructible tough, lightweight, abrasion-resistant, resilient and impervious to petrochemical solvents. The TP03 can run dry without damaging motor or impeller, reducing the possibility of downtime.

PART #	OUTLET SIZE	CAPACITY	FLOW RANGE	WEIGHT
TP03	3" Discharge	450 GPM	7-9 GPM	31 lbs.

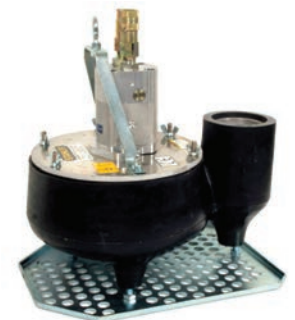

TRASH PUMP

A heavy-duty pump capable of pumping high volumes of water, sand slurries, gravel, sludge and solids up to 4" in diameter. The TP08 is submersible, self-priming and can run dry without damage to the motor, bearings or impeller.

PART #	OUTLET SIZE	CAPACITY	FLOW RANGE	WEIGHT
TP08	4" Camlock	800 GPM	7-9 GPM	59 lbs.



TENTS & VENTS



"A" STYLE GROUND TENT

"A" Model Tents include two screen windows with roll up flaps, three tie down cords through the hub, ground flaps, single-zippered front door, exterior roof line loops for tie-downs, carry case and three tent stakes.

PART #	SIZE	WEIGHT	FOLDED DIMENSIONS
6504A	48" x 48"	18 lbs.	6" x 46"
6506A	70" x 70"	20 lbs.	6" x 56"
6508A	94" x 94"	31 lbs.	7" x 66"
6510A	118" x 118"	34 lbs.	8" x 76"
6514A	166" x 166"	162 lbs.	10" x 124"



"D" STYLE GROUND TENT

"D" Model Tents include two screen windows with roll up flaps, three tie down cords through the hub, ground flaps, heavy-duty frame, wide open front, snap and D-rings with inter-connectable flaps (connect 2 tents together), ventilation hose entry sleeve interior and exterior roof line loops for tie-down, carry case and three tent stakes.

PART #	SIZE	WEIGHT	FOLDED DIMENSIONS
6506D	70" x 70"	21 lbs.	6" x 56"
6508D	94" x 94"	32 lbs.	7" x 66"
6510D	118" x 118"	36 lbs.	8" x 81"
6510C	118" x 118"	51 lbs.	8" x 88"
6512D	142" x 142"	94 lbs.	10" x 100"



VENT FAN

These axial steel constructed and powder painted models are our most popular. They are available in either 120 VAC (PART # 1325D) or 12 VDC (PART # 1400D). These units weigh only 19 pounds, and provide from 922 to 1075 cfm of fresh air. A suction adapter is also available (Model 3003P) for those special applications.

PART #	POWER	FREE AIR	DIMENSIONS (L x W x H)
1325D	Electric - 1/3 HP 120 VAC, 3 Amps	1075 cfm	14-1/2" x 13" x 14-1/2"
1400D	Electric - 1/4 HP 12 VDC, 15 Amps	922 cfm	14-1/2" x 13" x 14-1/2"



VENT FAN

The 1325P 120 VAC, electric blower is constructed of a durable, weather-resistant, high-impact polyethylene plastic. The unit also comes in 12 VDC (PART # 1400P). Weighing only 15 lbs., the units provide as much as 921 CFM.

PART #	POWER	FREE AIR	DIMENSIONS (L x W x H)
1325P	Electric - 1/3 HP 120 VAC, 3 Amps	921 cfm	18" x 14" x 15"
1400P	Electric - 1/4 HP 12 VDC, 15 Amps	814 cfm	18" x 14" x 15"



"AIRPAC" SERIES HOSE & CANISTER

Polyethylene canister and hose combination, which attaches to the 1325P & 1400P ventilators.

PART #	DESCRIPTION
Airpac 15	15' Hose & canister
Airpac 25	25' Hose & canister

CABLE PREPARATION



BANANA PEELER

An adjustable blade semi-con scoring tool.

PART #	RANGE
BP1A	.75" to 1.10"
BP2A	1.25" to 1.75"
34230	Replacement blade



SEMI-CON SCORER

This tool is adjustable and has a set screw to lock the depth.

PART #	RANGE
1700SS	1/2" to 2"
1800SS	1-3/4" to 3"
1678	Scoring blade



SPEED STRIPPER

Easily and quickly removes PE, XLP, EPR and other types of insulation from power cables. It has an O.D. Range of 1/2" to 1-3/4". This tool is supplied with the wedge blade installed and a spare straight blade.

PART #
1542-2CL

SPEED STRIPPER

Designed to strip insulation like the 1542-2CL but also scores the semi-con outer shield.

PART #
1542-2AS

SPEED STRIPPER REPLACEMENT BLADES

PART #	DESCRIPTION
1562	Wedge blade
1581	Straight blade

CABLE PREPARATION



CABLE STRIPPER

An adjustable cable end stripper that removes the outer jacket on primary power cable. A "Dual Position" jaw allows for cable diameters from 1/2" to 2-1/2".

PART #	DESCRIPTION
WS64UE	Complete unit
CB50K	Replacement blade



SECONDARY CABLE STRIPPER

An adjustable end stripper used to strip 600V cable without the use of bushings. Cable O.D. is .31" to 1-3/8".

PART #	DESCRIPTION
2750	Complete unit
2781	Replacement blade



CHAMFER TOOL

Creates a 45° bevel on XLPE insulations. Used for pre molded splices, elbows and terminators. Cable range from .650" to 1.260".

PART #
IC1



PROBE INSERTION TOOL

Fits all 15kV & 25kV & Elastimold 35kV elbows. The preset torque limiter takes the guesswork out of elbow probe & connector tightening.

PART #
LPW1525/TK120XN

CABLE PREPARATION

SQUARE CUT BUSHING FOR CONCENTRIC STRAND CONDUCTOR

CABLE SIZE	60 MIL INSULATION		80 MIL INSULATION		95 MIL INSULATION	
	MAX OD	PART #	MAX OD	PART #	MAX OD	PART #
#6	.315	10-32540			.390	10-40075
#4	.365	10-37540				
#2	.440	10-45040	.465	10-47560		
#1	.465	10-47540	.515	10-52560		
1/0	.515	10-52540	.565	10-57560	.590	10-60075
2/0	.565	10-57540	.590	10-60060	.640	10-65075
3/0	.615	10-62540	.665	10-67560	.690	10-70075
4/0	.665	10-67540	.715	10-72560	.740	10-75075
250			.765	11-77560	.790	11-80075
350			.865	11-87560	.890	11-90075
500			.990	11-100060	1.040	11-105075



4 X 4 PLUS CABLE END STRIPPER

Used for stripping 600 Volt cable.
4 Interchangeable cutting heads strip cables from # 6 AWG through 500 MCM.
Chamfer cut bushings also available.

PART #
36001H

SQUARE CUT BUSHINGS FOR COMPRESSED STRAND CONDUCTOR

CABLE SIZE	60 MIL INSULATION		80 MIL INSULATION		95 MIL INSULATION	
	MAX OD	PART #	MAX OD	PART #	MAX OD	PART #
#6	.315	10-32540			.390	10-40075
#4	.365	10-37540				
#2	.415	10-42540	.465	10-47560		
#1	.465	10-47540	.515	10-52560		
1/0	.490	10-50040	.540	10-55060	.590	10-60075
2/0	.540	10-55040	.590	10-60060	.615	10-62575
3/0	.590	10-60040	.640	10-65060	.665	10-67575
4/0	.665	10-67540	.690	10-70060	.740	10-75075
250			.740	10-75060	.765	11-77575
350			.840	11-85060	.890	11-90075
500			.965	11-97560	1.015	11-102575



2 X 2 PLUS CABLE END STRIPPER

2 Interchangeable cutting heads.
Chamfer cut bushings also available.

PART #
36101H

SQUARE CUT BUSHINGS FOR COMPACTED STRAND CONDUCTOR

CABLE SIZE	60 MIL INSULATION		80 MIL INSULATION		95 MIL INSULATION	
	MAX OD	PART #	MAX OD	PART #	MAX OD	PART #
#6	.315	10-32540			.390	10-40075
#4	.365	10-37540				
#2	.415	10-42540	.465	10-47560		
#1	.440	10-45040	.490	10-50060		
1/0	.465	10-47560	.515	10-52560	.565	10-57575
2/0	.515	10-52540	.565	10-57560	.590	10-60075
3/0	.565	10-57540	.615	10-62560	.640	10-65075
4/0	.615	10-62540	.665	10-67560	.690	10-70075
250			.715	11-72560	.740	11-75075
350			.790	11-80060	.840	11-85075
500			.915	11-92560	.965	11-97575

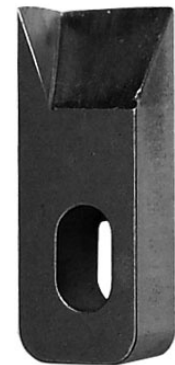

SQUARE CUT BLADE

For both the 2x2 and 4x4 bushings.
Chamfer cut bushings also available.

PART #
CB6667

DUCT RODDERS

All rodders are marked in 5' increments. Metric markings available upon request.



EASY BUDDY®

The flexible 1/4" rod has a 4" bending radius and a 400 lb. tensile strength. Designed to handle tight turns and long runs. 28-1/2" x 24" x 11".

PART #	DESCRIPTION
6-14-300M	300'
6-14-400M	400'



GOOD BUDDY®

3/8" OD fiberglass rod has a 7" bending radius and 1,000-lb pull/tensile strength. Reel detaches from frame and has a frame handle for easy transport. Features a friction brake and safety roller feed. Operates vertically or horizontally. Accessory kit, end ferrule and pulling eye included. Dimensions: 29" x 29" x 27".
Folds to 10" width.

PART #	DESCRIPTION
9-25-300M	300'
9-25-400M	400'



GOOD BUDDY II®

3/8" OD fiberglass rod has a 7" bending radius and 1,000 lb. pull/tensile strength. Oversized wheels to support weight of longer rod. Frame handle and wheels for transport. Friction brake and safety roller feed. Operates vertically or horizontally. Accessory kit, end ferrule and pulling eye included. Dimensions: 39" x 32" x 18".

PART #	DESCRIPTION
11A-25-400M	400'
11A-25-500M	500'
11A-25-600M	600'

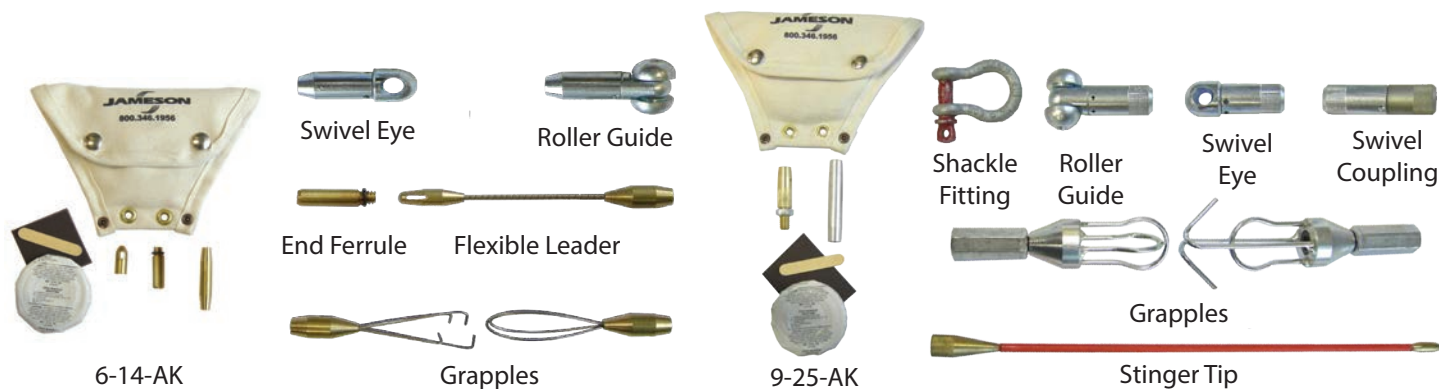

EASY BUDDY

GOOD BUDDY

ACCESSORIES

PART #	PART #	ITEM	DESCRIPTION
6-14-AK	9-25-AK	Accessory Kit	Splice, end ferrules, pulling eye, adhesive, emery cloth, pouch
6-139	9-139	Swivel Eye	A freely rotating eye for pull line or grip
6-140	9-140	Repair Kit	Splice ferrule, adhesive, emery cloth
6-141	9-141	Roller Guide	Guide through bends, sweeps and wires
6-148	9-148	Grapple Set	Connect 2 rodders from opposite directions
6-160	N/A	Pulling Eye	Attach to end fitting for pull line
6-162	N/A	Flexible Leader	Guide through bends, sweeps, misalignments
N/A	9-25-12ST	12" Stringer Tip	Guides rod through bends, sweeps, misalignments

DUCT RODDERS

All rodders are marked in 5' increments. Metric markings available upon request.

BIG BUDDY® DUCT RODDERS

A heavy duty rodder ideal for manhole-to-manhole work and long runs in 4" conduit and larger. Operates easily vertically or horizontally. The 1/2" rod has a 10" bending radius and a 1,400 lb. tensile strength. 47-1/2" x 44" x 20". Specify rod length when ordering.



PART #	AVAILABLE ROD LENGTHS
11-38M	400', 500', 600', 800' & 1,000'

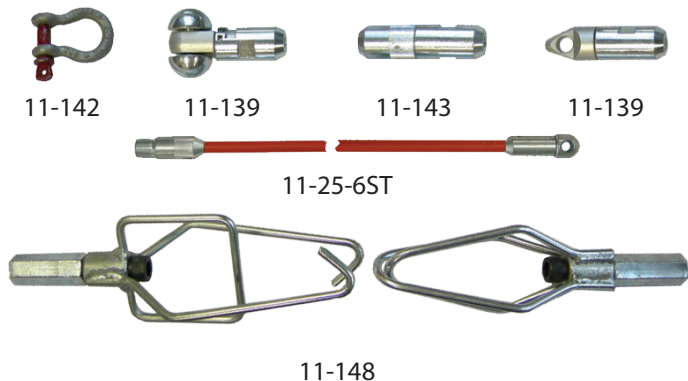

BIG BUDDY® ACCESSORIES

PART #	ITEM	DESCRIPTION
11-38-RK	Accessory Kit	2 Splice ferrules, end ferrule, emery cloth, adhesive & canvas pouch
11-139	Swivel Eye	Attaches pull line to rod
11-141	Roller Guide	Guides through bends, sweeps & wires
11-142	Shackle Fitting	Use with swivel eye for larger pulling loop
11-143	Swivel Coupling	Connects 2 rods & provides rotation to line
11-148	Grapple Set	Connects 2 rodders from opposite directions
11-25-6ST	6' Stinger Tip	Guides through bends, sweeps, misalignments
11-25-8ST	8' Stinger Tip	Guides through bends, sweeps, misalignments
11-140	Splice Repair Kit	Splice ferrule, adhesive & emery cloth
11-146	End Repair Kit	End ferrule, adhesive & emery cloth

DUCT HUNTER® DETECTABLE RODDERS

The Duct Hunter incorporates a copper trace wire in the rod to meet your locating and tracing requirements on the job. Trace or map up to 10' underground conduit or pipe without digging or trenching. Rigid frame and wheel construction. Rod's ferrule attaches to sonde, roller guide or pulling eye. Repair kit included.

PART #	ROD OUTSIDE DIAMETER	FIBERGLASS CORE DIAMETER	ROD LENGTH	MALE END FERRULE THREAD
12-516-300M	5/16"	3/16"	300'	3/8-16
12-516-400M	5/16"	3/16"	400'	3/8-16
13-716-500M	7/16"	5/16"	500'	3/8-16
13-716-600M	7/16"	5/16"	600'	3/8-16



DUCT RODDERS

WEE BUDDY® FISH TAPE

Designed for inside wiring in occupied conduit as small as 1/2", the Wee Buddy's round rod slides easily over existing wires, especially at bends, and has a smooth, non-binding payout and return to canister. The easy grip design allows for efficient pushing and pulling when fishing telecoms, voice and data or electrical conduit. Features: 1/8" O.D. fiberglass rod, 200 lb. pull/tensile strength. Available with our without accessory kit. Dimensions 12-1/2" x 2".



8-18-100K

PART #	DESCRIPTION
8-18-50	50' x 1/8" Wee Buddy
8-18-50K	50' x 1/8" Wee Buddy with accessory kit
8-18-100	100' x 1/8" Wee Buddy
8-18-100K	100' x 1/8" Wee Buddy with accessory kit
8-18-150	150' x 1/8" Wee Buddy
8-18-150K	150' x 1/8" Wee Buddy with kit

WEE BUDDY ACCESSORIES



8-18-AK

PART #	ITEM	DESCRIPTION
8-160	Pulling Eye	Attaches to end fitting of rod for pull line attachment to rod
8-162	Large Spring Leader	Guides rod through bends, sweeps and misalignments
8-163	Small Spring Leader	Guides rod through bends, sweeps and misalignments
8-140	Splice Repair Kit	Splice ferrule, adhesive, emery cloth, instructions
8-146	End Ferrule Repair Kit	End ferrule, adhesive, emery cloth, instructions
8-18-AK	Accessory Kit	Small leader, large leader, 2 pulling eyes, 2 splice ferrules, 2 End ferrules, adhesive, emery cloth, plastic case

LITTLE BUDDY

Lightweight, portable unit handles a variety of jobs, easily fishing conduit 3/4" to 1-1/2". Typically used for running inside and outside conduit drops as well as home drops from the hand-hole box to a building, some technicians use it for light pole and control wiring or walker ducts. 3/16" O.D. fiberglass rod, 2-1/2" bending radius, 200 lb. pull/tensile strength, accessory kit included. Dimensions: 22" x 17" x 7".



10-316-150

PART #	ROD LENGTH AND DIAMETER
10-316-150	150' x 3/16"
10-316-250	250' x 3/16"
10-316-300	300' x 3/16"

LITTLE BUDDY ACCESSORIES



10-316-AK

PART #	ITEM	DESCRIPTION
10-160	Pulling Eye	Attaches to end fitting of rod for pull line attachment to rod
10-162	Flexible Leader with Pull Eye	Guides rod through bends, sweeps and misalignments
10-163	Flexible Leader with Ball Tip	Guides rod through bends, sweeps and misalignments
10-140	Splice Repair Kit	Splice ferrule, adhesive, emery cloth, instructions
10-146	End Ferrule Repair Kit	End ferrule, adhesive, emery cloth, instructions
10-316-AK	Accessory Kit	2 Pulling eyes, 2 leaders, splice ferrule, 2 end ferrules, adhesive, emery cloth, pouch

DUCT RODDERS



BASKET COMBINATION

Used to connect two hand rods pushed into the conduit from opposite ends of the conduit run. Both rods can then be pulled out in one direction. Used instead of a swivel coupling when the full length of the rod is difficult to push from one end.

Does not negotiate tight bends.

PART #	SIZE
08031300	3/4" x 10'



FIBERGLASS HAND RODS

Screw together fiberglass duct rods for straight runs. All rods equipped with 3/4"-10 end fittings. 2,500 lbs. pull rating.

PART #	SIZE
08032026	5/8" x 5'
08032022	5/8" x 10'

"PYTHON" DUCT RODDERS

A heavy-duty outer plastic coating resists abrasions and reduce wear.

The 5/16" models come in a 30" cage. The 7/16" models come in a 45" cage.

Both styles have 3/8"-16 end fittings. Available in additional diameters and lengths.

5/16" PYTHON		7/16" PYTHON	
PART #	LENGTH	PART #	LENGTH
08084320	200'	08083920	200'
08084330	300'	08083930	300'
08084340	400'	08083940	400'
08084350	500'	08083950	500'
08084360	600'	08083960	600'
08084370	700'	08083970	700'
08084380	800'	08083980	800'
08083790	900'	08083990	900'
08084310	1,000'	08083910	1,000'
		08083911	1,100'
		08083912	1,200'



REPAIR KIT

PART #	SIZE
08035774	5/16"
08035776	7/16"



ACCESSORY KIT

PART #	SIZE
08033497	5/16"
08033494	7/16"



SPLICE KIT

PART #	SIZE
08035753	5/16"
08035751	7/16"

LINE BLOWING



08030003

POWER DART BLOWER

Includes 100V Power Dart Blower unit, hose, seal-off body & seal-offs for 1/2" - 6".

PART #	DESCRIPTION
08030003	Power dart blower kit
08030060	Accessory storage bag



INNERDUCT SEAL-OFFS

PART #	NOMINAL DUCT SIZE	INNER DUCT I.D. RANGE
08034315	1"	.93" - 1.19"
08034316	1-1/4"	1.18" - 1.44"
08034317	1-1/2"	1.31" - 1.69"
08034318	2"	1.93" - 2.31"



SINGLE CONDUIT SEAL-OFFS

PART #	NOMINAL DUCT SIZE	INNER DUCT I.D. RANGE
08032900	2"	1.93" - 2.36"
08032905	2.5"	2.40" - 2.76"
08032910	3"	2.87" - 3.31"
08032915	3.5"	3.50" - 3.75"
08032920	4"	3.54" - 4.25"
08032925	5"	4.72" - 5.37"
08032930	6"	5.50" - 6.29"
08032935	8"	7.83" - 8.27"

Double seal-offs are available.



SEAL-OFF VALVE BODY

For use with the inner duct seal-offs and single & double conduit seal-offs.

PART #
08032165



RUBBER DUCT PROJECTILES

PART #	DESCRIPTION
08031812	1-1/4" Duct projectile
08031814	1-3/8" Duct projectile
08031815	1-1/2" Duct projectile
08031816	1-5/8" Duct projectile
08031820	2" Duct projectile
08031822	2-1/4" Duct projectile
08031825	2-1/2" Duct projectile
08031830	3" Duct projectile
08031835	3-1/2" Duct projectile
08031840	4" Duct projectile
08031844	4-1/4" Duct projectile
08031846	4-1/4" Duct projectile
08031850	5" Duct projectile
08031860	6" Duct projectile
08031880	8" Duct projectile



FOAM CARRIERS

PART #	DESCRIPTION
08078200	1/2" Foam carrier
08078300	3/4" Foam carrier
08032200	1" Foam carrier
08032300	1-1/4" Foam carrier
08039800	1-1/2" Foam carrier
08032400	2" Foam carrier
08078400	2-1/2" Foam carrier
08032500	3" Foam carrier
08032100	3-1/2" Foam carrier
08032600	4" Foam carrier
08059100	5" Foam carrier
08059200	6" Foam carrier



LINE CARRIERS

PART #	DESCRIPTION
08067900	2" Line carrier
08030100	3" Line carrier
08030200	3-1/2" Line carrier
08030300	4" Line carrier
08030400	5" Line carrier
08030500	6" Line carrier

DUCT MANDRELS



SHORT RUBBER SLUG

For proving duct integrity and for spreading cable pulling lubricant especially in tight radius bends.
4,500 lbs. load capacity.

PART #	DUCT SIZE	BODY LENGTH	MAX O.D.
08082020	2"	3.25"	2"
08082025	2.5"	3.25"	2.5"
08082030	3"	3.25"	3"
08082035	3.5"	3.25"	3.5"
08082040	4"	3.25"	4"
08082050	5"	3.25"	5"
08082060	6"	3.25"	6"
08082080	8"	3.25"	8"



FLEXIBLE STEEL MANDREL

Steel discs in graduated sizes make this mandrel ideal for removing obstructions in ducts with extreme bends.
7,000 lbs. load capacity. * 2,000 lbs. load capacity.

PART #	DUCT SIZE	BODY LENGTH	MAX O.D.	LOAD
08021700*	2"	7.31"	1.75"	2,000 lbs.
08021925	2.5"	7.31"	1.75"	7,000 lbs.
08021800	3"	7.31"	1.75"	7,000 lbs.
08049400	3.5"	7.31"	1.75"	7,000 lbs.
08067400	4" Sch 80	7.31"	1.75"	7,000 lbs.
08021900	4"	7.31"	1.75"	7,000 lbs.
08067500	5" Sch 80	7.31"	1.75"	7,000 lbs.
08058900	5"	7.31"	1.75"	7,000 lbs.
08067600	6" Sch 80	7.31"	1.75"	7,000 lbs.
08059000	6"	7.31"	1.75"	7,000 lbs.
08079500	8"	7.31"	1.75"	7,000 lbs.



WIRE BRUSH MANDREL

Flat steel bristles with a pulling eye on one end and a loop on the other end. Easily removes sand, grit and other light obstructions from the duct. 800 lbs. load capacity.

PART #	DUCT SIZE	BODY LENGTH	OVERALL LENGTH	MAX O.D.
08028904	1.25"	4.25"	7.5"	1"
08028905	1.5"	4.25"	7.5"	1.25"
08028900	2"	4.25"	9.16"	1.75"
08046000	2.5"	4.25"	9.16"	2.25"
08067100	3"	5.50"	9.16"	2.75"
08067200	3.5"	5"	9.16"	3.25"
08029000	4"	6.75"	9.16"	3.75"
08029100	5"	6.5"	9.16"	4.75"
08068100	6"	6.75"	9.16"	5.75"
08029080	8"	4.75"	9.73"	7.75"



HEAVY-DUTY WIRE BRUSH MANDREL

Heavy-duty steel bristles with pulling eyes on each end for removing obstructions from the duct.

PART #	DUCT SIZE	BODY LENGTH	MAX O.D.	LOAD
08900546	2"	3.5"	1.75"	1,240 lbs.
08900547	2.5"	4.25"	2.25"	1,240 lbs.
08900548	3"	5.25"	2.75"	1,240 lbs.
08900549	3.5"	5.25"	3.25"	2,240 lbs.
08900550	4"	5.25"	3.75"	2,240 lbs.
08900551	5"	5"	4.75"	2,240 lbs.
08900552	6"	5"	5.75"	2,240 lbs.
08900553	8"	5"	7.75"	2,240 lbs.

DUCT MANDRELS

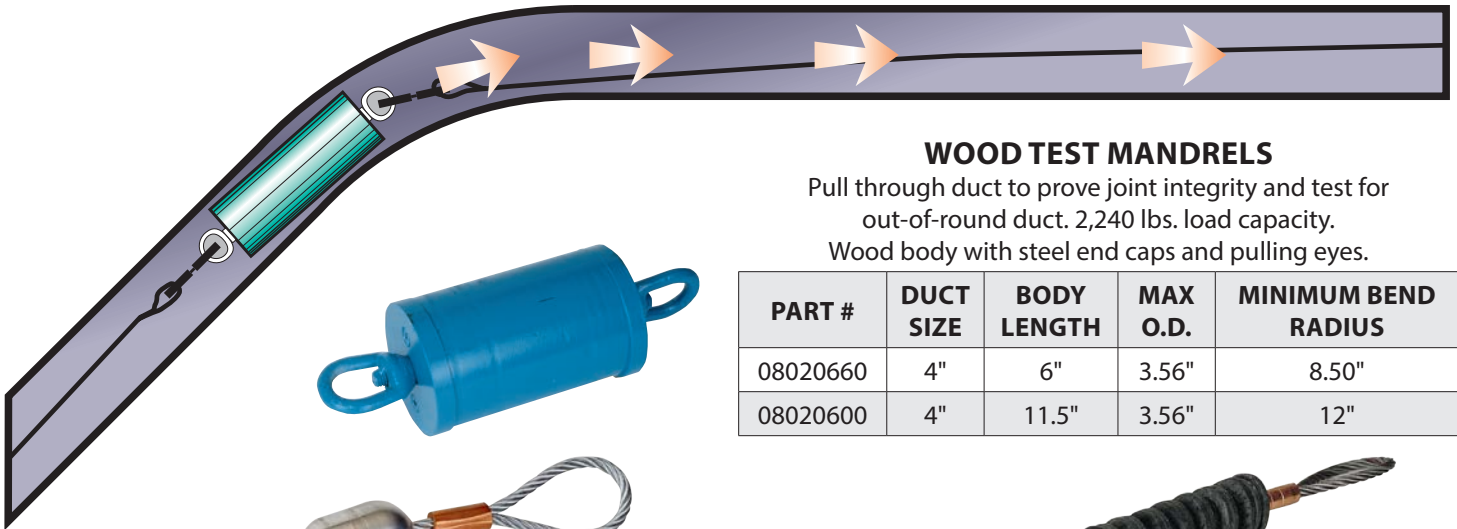

WOOD TEST MANDRELS

Pull through duct to prove joint integrity and test for out-of-round duct. 2,240 lbs. load capacity.
Wood body with steel end caps and pulling eyes.

PART #	DUCT SIZE	BODY LENGTH	MAX O.D.	MINIMUM BEND RADIUS
08020660	4"	6"	3.56"	8.50"
08020600	4"	11.5"	3.56"	12"

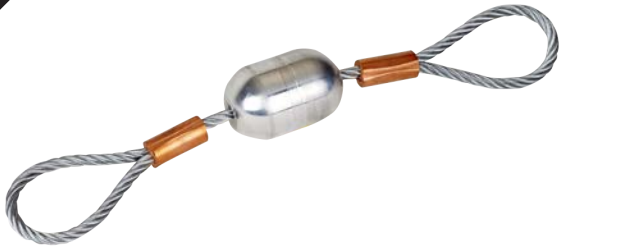

ALUMINUM TEST MANDRELS

Pull through duct to prove joint integrity and test for out-of-round duct. Provides an 80% fill in schedule 40 and telephone conduit.

PART #	DUCT SIZE	BODY LENGTH	MAX O.D.	LOAD CAPACITY
08059515	1.5"	1.74"	1.18"	2,200 lbs.
08059520	2"	2.40"	1.62"	2,200 lbs.
08059525	2.5"	2.98"	2"	2,200 lbs.
08059530	3"	3.5"	2.37"	2,200 lbs.
08059535	3.5"	4.10"	2.75"	4,500 lbs.
08059540	4"	4.84"	3.25"	4,500 lbs.
08059550	5"	5.98"	4"	4,500 lbs.
08059560	6"	7.08"	4.75"	4,500 lbs.
08059580	8"	9.44"	6.375"	4,500 lbs.

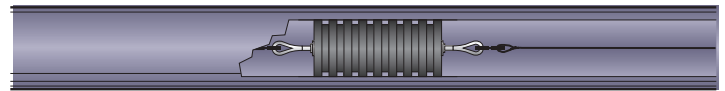

RUBBER DUCT SWAB

Ideal for cleaning and assisting in the spreading of lubricant throughout the duct.

PART #	DUCT SIZE	BODY LENGTH	MAX O.D.	LOAD CAPACITY
08028820	2"	10"	2"	4,500 lbs.
08028830	3"	10"	3"	7,000 lbs.
08028700	3.5"	10"	3.5"	7,000 lbs.
08028800	4"	10"	4"	7,000 lbs.
08058700	5"	10"	5"	7,000 lbs.
08058800	6"	10"	6"	7,000 lbs.
08022880	8"	10"	8"	7,000 lbs.



ALUMINUM TEST SLUGS

Pull through duct to prove joint integrity and test for out-of-round duct.
Provides an 80% fill in Schedule 40 and telephone conduit.

PART #	DUCT SIZE	BODY LENGTH	MAX O.D.	LOAD CAPACITY
08059005	1"	1.71"	.860"	2,200 lbs.
08059015	1.25"	2.17"	1.086"	2,200 lbs.
08059025	1.5"	2.49"	1.243"	2,200 lbs.

UNDERGROUND CABLE PULLING

Other sizes available.



MULTIPLE PULLING HARNESS

Allows staggered attachment to cable or innerduct when pulling through conduit systems or during directional drilling pull-back operations. Other harness combinations available upon request. Contact factory for details.

PART #	DESCRIPTION	WORKING LOAD PER LEG	WORKING LOAD COMBINED	MAXIMUM WIDTH A	SEPARATION BETWEEN LEGS		LEAD RING DIAMETER C
					B		
08549200	3 way .125" cable	550 lbs.	1,600 lbs.	2.25"	14"		.37"
08549230	3 way .25" cable	1,400 lbs.	2,900 lbs.	2"	14"		.37"
08549325	4 way .25" cable	1,400 lbs.	4,200 lbs.	2"	14"		.37"
08549333	3 way .375" cable	4,800 lbs.	9,000 lbs.	2.63"	10"		.62"
08549329	4 way .375" cable	4,800 lbs.	9,000 lbs.	2.63"	10"		.62"
08549331	2 way .5" cable	7,000 lbs.	10,000 lbs.	2.5"	12"		.50"
08549332	3 way .5" cable	7,000 lbs.	15,000 lbs.	3.75"	12"		.87"
08549340	1 way .5" cable	7,000 lbs.	15,000 lbs.	3.75"	12"		.87"

REUSABLE CABLE PULLING EYES

Reusable Cable Pulling Eyes waste virtually no cable and all components are completely reusable.

These eyes will remain firmly secured on the cable for a confident pull. No special tools or crimpers are required for installation.

Three designs of Reusable Power Pulling Eyes are available: Clevis Head, Standard Head, and Swivel Head.

Other sizes available.

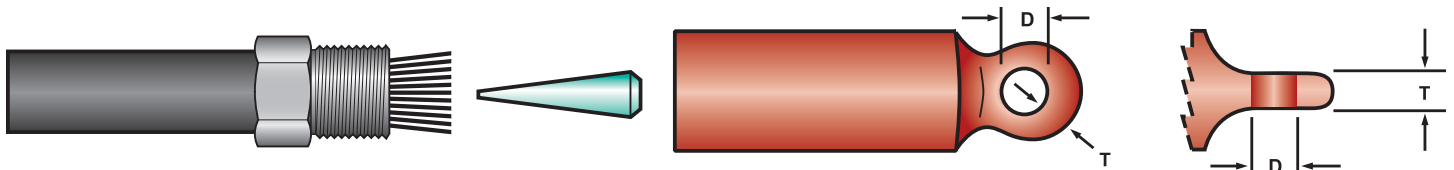

STANDARD HEAD PULLING EYES

PART #	CABLE SIZE (KCMIL)	COLOR	MAXIMUM CONDUCTOR DIAMETER	MAXIMUM EYE O.D.	HOLE DIAMETER D	EYE THICKNESS T	REPLACEMENT PLUG PART #
08960520	1/0 AWG	Red	.373"	.88"	.50"	.34"	08960523
08960820	2/0 AWG	Black	.419"	1"	.50"	.34"	08960823
08960420	4/0 AWG	Green	.528"	1"	.50"	.34"	08960423
08960320	250	Blue	.575"	1.13"	.63"	.50"	08960323
08917520	350	White	.681"	1.25"	.75"	.50"	08917523
08918320	400	Black	.7125"	1.44"	.81"	.50"	08918323
08917420	500	Yellow	.813"	1.5"	.81"	.50"	08917423
08918220	600	Green	.9367"	1.75"	.63"	.43"	08918223
08917320	700	Gray	.964"	1.75"	.60"	.43"	08917323
08917220	750	Brown	.998"	1.75"	.60"	.43"	08917223
08917120	1000	Orange	1.152"	2.06"	1"	.50"	08917123

UNDERGROUND CABLE PULLING

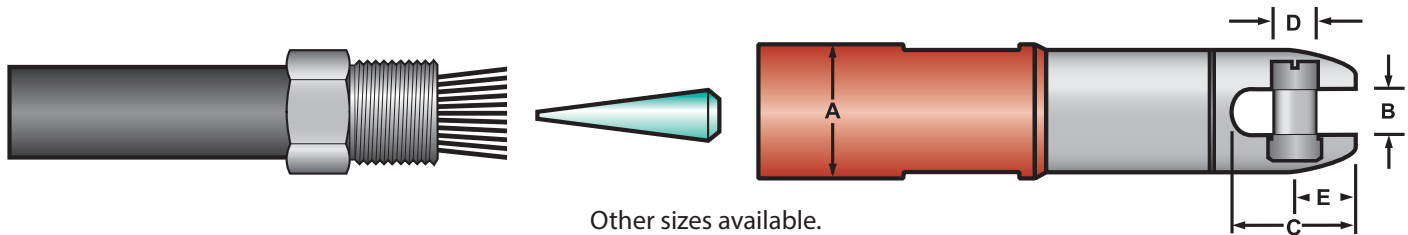

SWIVEL HEAD PULLING EYES

PART #	CABLE SIZE (KCMIL)	COLOR	MAXIMUM CONDUCTOR DIAMETER	MAX EYE O.D. A	SLOT WIDTH B	SLOT DEPTH C	PIN DIAMETER D	PIN CENTER E	REPLACEMENT PLUG PART #
08960575	1/0 AWG	Red	.373"	.88"	.38"	1.06"	.31"	.53"	08960523
08960875	2/0 AWG	Black	.419"	1"	.38"	1.06"	.31"	.53"	08960823
08960475	4/0 AWG	Green	.528"	1"	.38"	1.06"	.31"	.53"	08960423
08960375	250	Blue	.575"	1.13"	.38"	1.06"	.31"	.53"	08960323
08917575	350	White	.681"	1.25"	.56"	1.34"	.38"	.59"	08917523
08918375	400	Black	.7125"	1.44"	.43"	1.40"	.44"	.59"	08918323
08917475	500	Yellow	.813"	1.44"	.56"	1.31"	.44"	.59"	08917423
08918275	600	Green	.9367"	1.75"	.63"	1.59"	.56"	.78"	08918223
08917375	700	Gray	.964"	1.75"	.63"	1.59"	.56"	.78"	08917323
08917275	750	Brown	.998"	1.75"	.63"	1.59"	.56"	.78"	08917223
08917175	1000	Orange	1.152"	2.06"	.75"	1.78"	.63"	.72"	08917123



CLEVIS HEAD PULLING EYES

PART #	CABLE SIZE (KCMIL)	COLOR	MAXIMUM CONDUCTOR DIAMETER	MAX EYE O.D. A	SLOT WIDTH B	SLOT DEPTH C	PIN DIAMETER D	PIN CENTER E	REPLACEMENT PLUG PART #
08960550	1/0 AWG	Red	.373"	.88"	.38"	1.06"	.31"	.53"	08960523
08960850	2/0 AWG	Black	.419"	1"	.38"	1.06"	.31"	.53"	08960823
08960450	4/0 AWG	Green	.528"	1"	.38"	1.06"	.31"	.53"	08960423
08960350	250	Blue	.575"	1.13"	.38"	1.06"	.31"	.53"	08960323
08917550	350	White	.681"	1.25"	.56"	1.34"	.38"	.59"	08917523
08918350	400	Black	.713"	1.44"	.43"	1.40"	.44"	.59"	08918323
08917450	500	Yellow	.813"	1.44"	.59"	1.41"	.44"	.59"	08917423
08918250	600	Green	.9367"	1.75"	.63"	1.59"	.56"	.78"	08918223
08917350	700	Gray	.964"	1.75"	.63"	1.59"	.56"	.78"	08917323
08917250	750	Brown	.998"	1.75"	.63"	1.59"	.56"	.78"	08917223
08917150	1000	Orange	1.152"	2.06"	.75"	1.78"	.63"	.72"	08917123

CABLE FEEDING

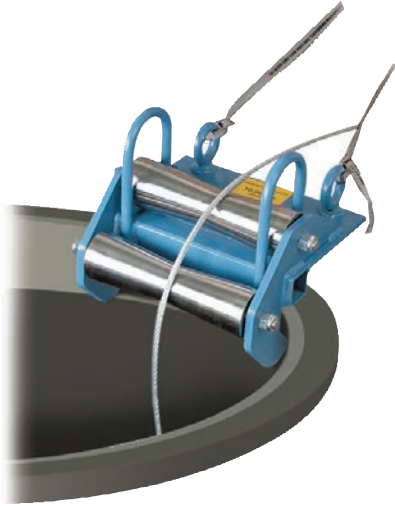

MINI CORNER CABLE GUIDE

Guides steel winch lines over sharp edges.

PART #
08045000



2 SHEAVE CORNER CABLE GUIDE

Aluminum sheaves for pulling cable into manholes. 5,000 lbs. cable tension load capacity.

PART #	SIZE
08040000	3"
08043100	4"
08043200	5"
08088600	6"
08088800	8"



CABLE FEEDING SHEAVES

PART #	SIZE	O.D.
08617215	1-1/2"	1.44"
08617220	2"	1.95"
08617225	2-1/2"	2.40"
08617230	3"	2.95"
08617235	3-1/2"	3.38"
08617200	4"	3.95"
08617250	5"	4.90"
08617260	6"	5.90"
08617280	8"	7.94"



NYLON CABLE PROTECTOR

Flanged, split tube to insert in duct end and protect cable from damage during installation. Also can be left in place for permanent protection.

PART #	DESCRIPTION
08042301	1" - 2-1/2" duct
08042300	3" - 6" duct



HOOKED HANGER SHEAVES

PART #	SIZE
08041400	3" x 11"
08042400	4" x 11"
08042420	4" x 20"
08042500	5" x 11"
08042520	5" x 20"
08042526	5" x 26-1/2"
08082600	6" x 11"
08082800	8" x 11"



3 SHEAVE CORNER CABLE GUIDE

The three sheaves allows a gradual 90° turn with a pulling radius of 24". It will sit on manhole edge, suspend in manhole or fit the jamb skid.

PART #	DESCRIPTION
08539600	6" Sheaves
08539800	8" Wide sheaves

MANHOLE EQUIPMENT



ALUMINUM SPLIT BELLS

Plugs into conduit in manhole wall, guiding cable safely into the conduit regardless of the pulling angle.

PART #	SIZE	TUBE LENGTH	TUBE I.D.	TUBE O.D.
08041520	2"	8"	1.625"	1.875"
08041530	3"	8"	2.625"	2.875"
08041535	3.5"	8"	3.125"	3.375"
08041540	4"	8"	3.625"	3.875"
08041550	5"	8"	4.625"	4.875"
08041560	6"	8"	5.625"	5.875"
08041564	6"	12"	5.625"	5.875"
08041570	8"	12"	7.875"	7.500"
08041515	4"	15"	3.625"	3.875"
08041518	4"	18"	3.625"	3.875"



STEEL DUCT ADAPTERS

PART #	DUCT ADAPTER DIAMETER	DUCT SIZE	STYLE	I.D.	O.D.
08040300	4"	3"	Round	2.93"	2.68"
08040400	4"	3.25"	Round	3.06"	2.81"
08040600	4"	3.5"	Round	3.43"	3.18"
08040800	4"	4"	Round	3.81"	3.62"
08087200	4"	5"	Round	4.81"	4.63"
08040900	5"	4"	Round	3.87"	3.69"
08041300	5"	5"	Round	4.81"	4.62"
08041200	5"	6"	Round	5.81"	4.62"
08087000	6"	5"	Round	4.81"	4.62"
08086800	6"	6"	Round	5.81"	5.62"
08040133	4"	3.25"	Square	-	2.81"
08040136	4"	3.5"	Square	-	3.25"
08040142	4"	4"	Square	-	3.62"



FLEXIBLE CABLE GUIDES WITH ALUMINUM ADAPTERS

Cable feeds through the Bell Adapter and exits through the Duct Adapter which fits into the duct.

PART #	DIA.	LENGTH	PART #	DIA.	LENGTH
08931009	2"	9'	08935012	5"	12'
08931012	2"	12'	08936009	6"	9'
08934009	4"	9'	08936012	6"	12'
08934012	4"	12'	08988009	8"	9'
08935009	5"	9'	08988012	8"	12'



SPLIT CABLE GUIDE

Ease of removal from cable being installed allows for "figure-eight" type installation, so cable remaining on reel can be pulled in a different direction without having to terminate and splice. Ideal for use with preconnectorized cables. Split feeder is hinged on one side and has a series of flexible latches on the other side to allow full closure. 4" split guide diameter, 7-1/2' split guide length.

PART #
08064700

MANHOLE EQUIPMENT

JAMB SKID

Used for supporting sheaves or quadrant blocks inside a manhole to pull cable into underground conduit.



PART #	SIZE	DESCRIPTION
08097000	58"	Base section with locking pins
08097001	43"	Extension
08097002	76"	Extension
08097003	109"	Extension

REPLACEMENT PINS

PART #	DESCRIPTION
08097040	1-1/4" Diameter pin
08097060	Locking pin kit

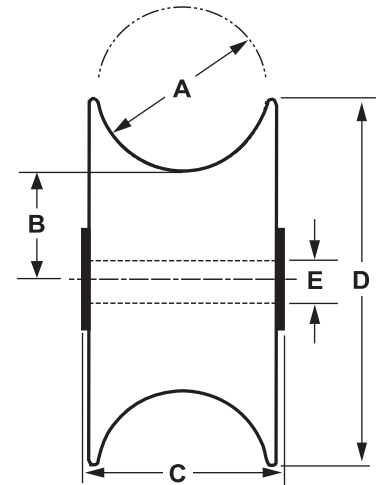
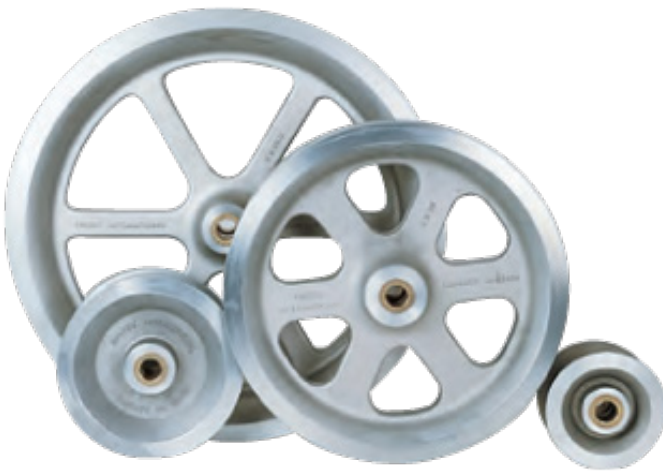

SHEAVES SPECIFICATIONS

Refer to this chart for specifications on sheave sizes for the Jamb Skid.

PART #	SHEAVE SIZE	MAXIMUM CABLE O.D. A	MINIMUM BENDING RADIUS B	MAXIMUM SHEAVE WIDTH C	MAXIMUM SHEAVE O.D. D	SHAFT DIAMETER E
08539308	1" x 3"	1.5"	.75"	3"	3"	.62"
08539036	3" x 7"	3"	2.25"	3.72"	7"	1.25"
08539136	4" x 7"	4"	2.25"	4.31"	7"	1.25"
08539236	5" x 7"	5"	2.25"	5.13"	7"	1.25"
08046811	3" x 11"	3"	4.25"	3.75"	11"	1.25"
08046711	4" x 11"	4"	3.75"	4.75"	11"	1.25"
08046811	5" x 11"	5"	3.25"	5.75"	11"	1.25"
08087811	6" x 11"	6"	3.12"	6.75"	11"	1.25"
08087911	8" x 11"	8.25"	2.75"	8.75"	11"	1.25"
08065411	4" x 20"	4.25"	8.5"	4.75"	20"	1.25"
08042911	5" x 20"	5"	8"	5.75"	20"	1.25"
08637743	3" x 24"	1.38"	11.12"	4"	24.12"	1"
08043011	5" x 26-1/2"	5"	11.31"	5.75"	26.5"	1.25"

INNERDUCT PULLING EYES

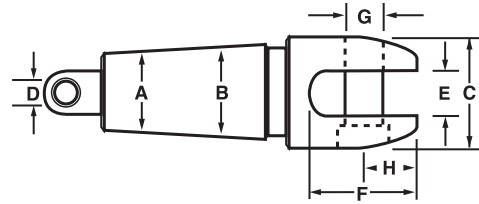

CLEVIS HEAD INNERDUCT PULLING EYE

PART #	NOMINAL SIZE	INNERDUCT I.D. RANGE	MAXIMUM O.D. C	HOLE DIAMETER D	SLOT WIDTH E	SLOT DEPTH F	PIN DIAMETER G	PIN CENTER H
08914310	.75"	.71" - .87"	1.25"	.25"	.56"	1.34"	.38"	.59"
08914320	1"	.93" - 1.06"	1.38"	.25"	.56"	1.34"	.44"	.56"
08914330	1.25"	1.06" - 1.43"	1.75"	.38"	.75"	1.78"	.63"	.81"
08914340	1.5"	1.37" - 1.68"	2"	.38"	.75"	1.78"	.63"	.72"
08914350	1.75"	1.68" - 1.81"	2.25"	.38"	.75"	1.78"	.63"	.72"
08914360	2"	1.93" - 2.12"	2.5"	.38"	.75"	2.5"	.88"	1.23"

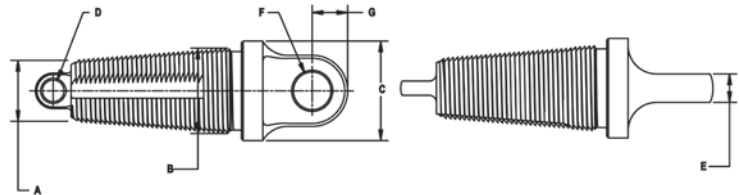

CLEVIS HEAD INNERDUCT PULLING EYE

PART #	NOMINAL SIZE	INNERDUCT I.D. RANGE	MAX O.D. C	HOLE DIAMETER D	TANG THICKNESS E	TANG HOLE DIAMETER F	TANG HOLE LOCATION G
08914110	.75"	.71" - .87"	1.25"	.25"	.38"	.5"	.5"
08914120	1"	.93" - 1.06"	1.38"	.25"	.38"	.5"	.5"
08914130	1.25"	1.06" - 1.43"	1.75"	.38"	.5"	.66"	.63"
08914140	1.50"	1.37" - 1.68"	2"	.38"	.5"	.66"	.63"
08914150	1.75"	1.68" - 1.81"	2.25"	.38"	.5"	.66"	.75"
08914160	2"	1.93" - 2.12"	2.5"	.38"	.5"	.81"	.75"

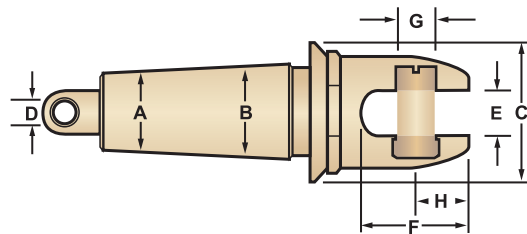

SWIVEL HEAD INNERDUCT PULLING EYE

PART #	NOMINAL SIZE	INNERDUCT I.D. RANGE	MAX O.D. C	HOLE DIAMETER D	SLOT WIDTH E	SLOT DEPTH F	PIN DIAMETER G	PIN CENTER H
08960712	1-1.25"	1.06" - 1.43"	1.75"	.44"	.56"	1.31"	.44"	.56"
08960715	1.5"	1.37" - 1.68"	2"	.44"	.56"	1.31"	.44"	.56"
08960720	2"	1.93" - 2.12"	2.44"	.44"	.56"	1.31"	.44"	.56"

UNDERGROUND EQUIPMENT

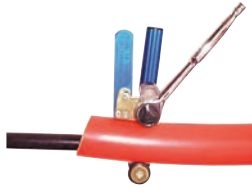

INNERDUCT SLITTER

Mechanical Innerduct Slitter is designed to reduce the effort required to longitudinally slit long sections of both high density Polyethylene (HDPE) and medium density Polyethylene (MDPE) innerduct and conduit that have an outside diameter ranging from 1.25" to 2". Kit includes: slitter, double-sided replacement blade, blue leather storage bag, allen key that fits all screws, set of instructions.

PART #	DESCRIPTION
08012925	Innerduct slitter
08013101	Replacement blade



CABLE JACKET AND INNERDUCT SLITTER

Makes quick, safe work of slitting Innerduct or removing sheath and turnplate from communication cables. Minimum cable diameter 1". Slits 1" - 2" Innerduct.

PART #	DESCRIPTION
08012900	Cable jacket and innerduct slitter
08012901	Replacement blade



MANHOLE COVER LIFTING HOOKS

PART #	LENGTH
08023001	18"
08023000	26-1/2"
08023002	36"
08023003	36" - 90° hook
08023005	30" - 90° hook



INNERDUCT JACKET SLITTER

Designed for fast, safe cutting of innerducts from 1" to 2".

PART #	DESCRIPTION
08013100	Innerduct jacket slitter
08013101	Replacement blade



PVC & POLYETHYLENE CUTTER

Razor sharp cutting blade makes a fast, clean, burr-free cut in PVC and polyethylene. Ratcheting handle provides for sure, steady cutting action. Reduces cutting and preparation time.

PART #	DESCRIPTION
08948050	Up to 1-1/4" conduit with 1.5" O.D.
08948060	Up to 2" conduit with 2.375" O.D.
08948051	Replacement blade for 08948050
08048061	Replacement blade for 08948060



HIGH IMPACT POLYMER MANHOLE SHIELD

Constructed of rugged lightweight polyethylene with bright yellow material that resists fading. Will fit 27", 30" and 32" diameter manholes with an inflatable seal that ensures a watertight seal. Designed with four (4) outrigger support gussets that stabilize the shield and is 12" tall to keep water and mud out of the manhole as you work.

Can be used with guardrail.

PART #	DESCRIPTION
08043400	Manhole shield
08043410	Watertight seal (sold separately)

MANHOLE GUARD RAIL

Furnished with two steel chains and wing bow locking brace to assure sturdy protection. Painted safety yellow. Freestanding.

PART #	DESCRIPTION	HEIGHT	LENGTH	WIDTH	WEIGHT
08043300	Manhole guard rail	42"	32"	32-1/4"	32 lbs.
08043301	Manhole guard rail with shield clamps	42"	32"	32-1/4"	32 lbs.



176-A-78 REPAIR PARTS

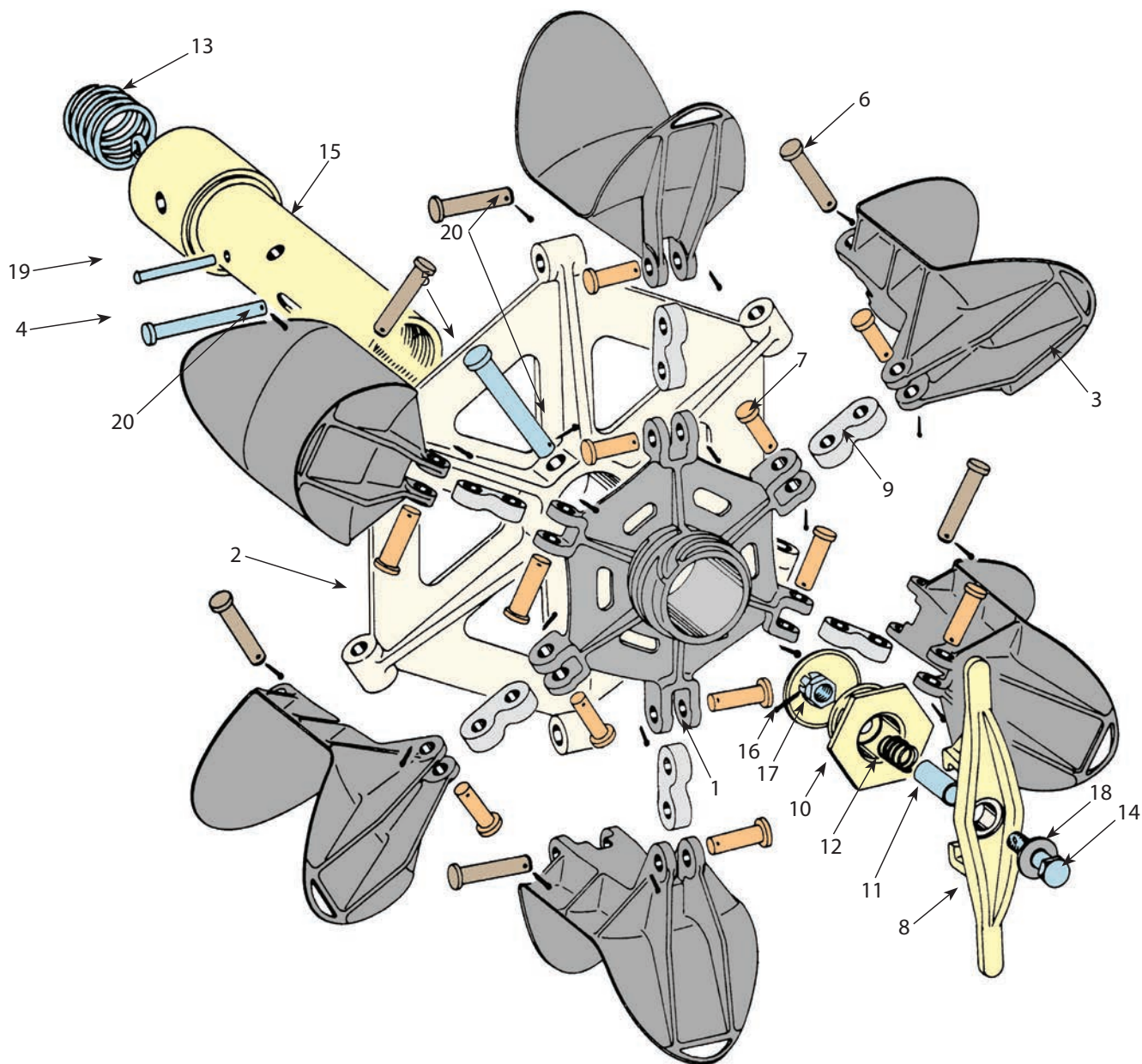

ITEM #	PART #	QTY.	DESCRIPTION
1	MV-3H043	1	Sliding Spider (Steel)
2	MV-3H044	1	Fixed Spider (Aluminum)
3	MV-3H053	6	Rim Segments (Saddles)
4	MV-3H069	1	Sliding Pin, 4-11/16"
5	MV-3H070	1	Pin, 4-11/16"
6	MV-3H072	6	Pivot Pin, 2-7/8"
7	MV-3H073	12	Reel Arm Pin, 2"
8	MV-3H138	1	Handle
9	MV-3H177	6	Link (Aluminum)
10	MV-3H180	1	Spindle Plug
11	MV-3H192	1	Spacer

ITEM #	PART #	QTY.	DESCRIPTION
12	MV-3H255	1	Spring
13	MV-3H258	1	Spindle Spring
14	MV-3H274	1	Handle Bolt, 5/8" x 3-1/4"
15	MV3H283	1	Spindle Assembly
16	MV-3H291	1	Spindle Shim
17	CN-10	1	Castle Nut, 5/8"
18	PW-10	1	Plain Washer, 5/8"
19	SP-3	1	Pin, 3/8" x 3-1/8"
20	CP-18	20	Cotter Pin, 1/8" x 1"
21	118745	1	Handle & Plug Assembly *

* Consisting of Parts 8, 10, 11, 12, 14, & 18

6990FS REPAIR PARTS

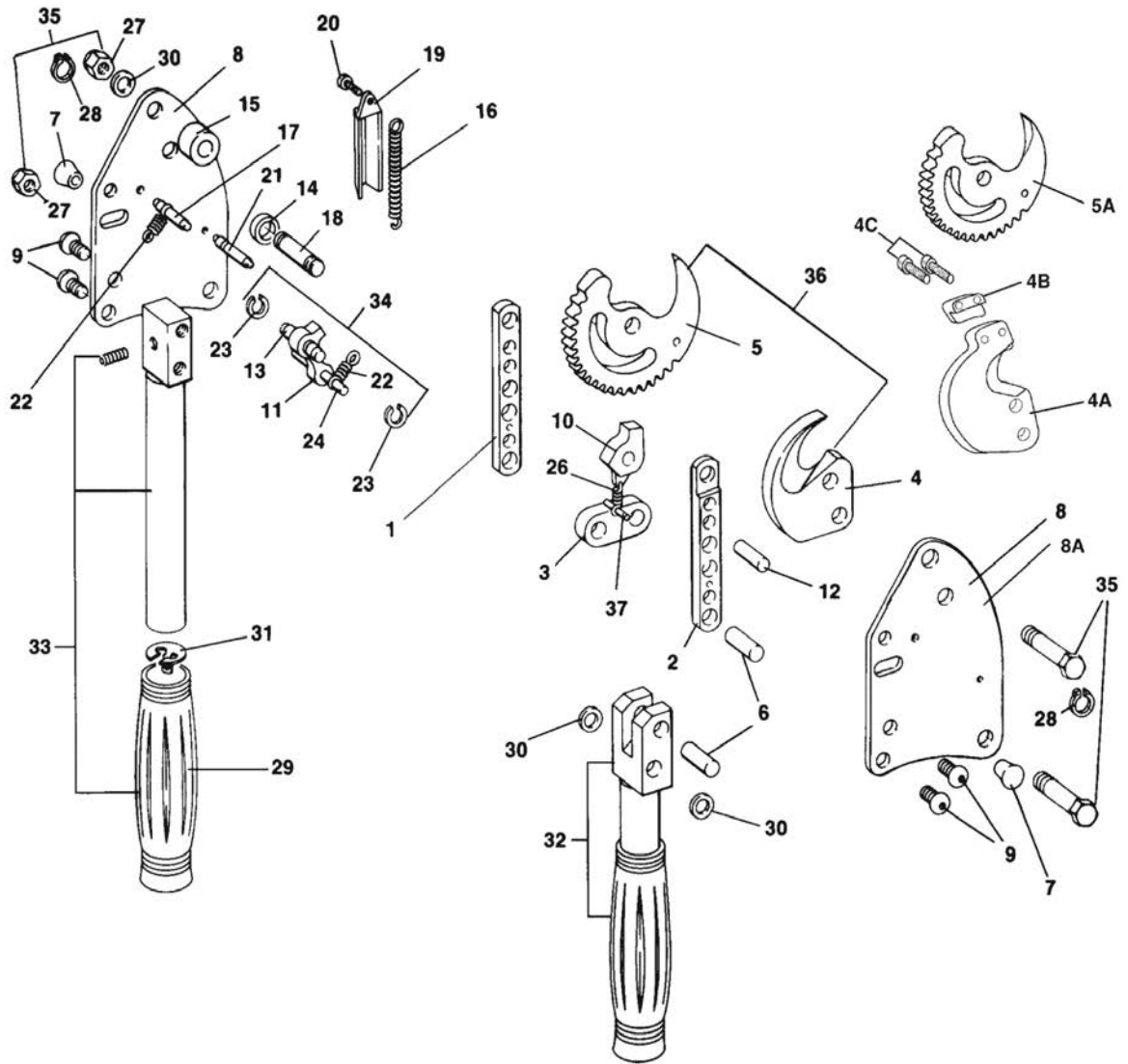

ITEM #	PART #	DESCRIPTION	ITEM #	PART #	DESCRIPTION	ITEM #	PART #	DESCRIPTION
1	6903FS	Link, R.H.	10	6936FS	Pawl	24	6985FS	Pin, Pivot
2	6904FS	Link, L.H.	11	6937FS	Detent	25	6992FS	Pin, Detent
3	6907FS	Link, Drive	12	6941FS	Pin, Pivot	26	6953FS	Spacer
4	6910FS	Blade, Stationary	13	6942FS	Pin, Detent	27	6993FS	Spacer
4A	6910FH	Blade, Stationary (#6990FHL Only)	14	6944FS	Spacer	28	9437	Spring
4B	6954FH	Keeper (#6990FHL Only)	15	6945FS	Spacer	29	0180SC	Pin, Stop
4C	69624FHA	Bolt (#6990FHL Only)	16	6958FS	Spring	30	6943FS	Pin, Pivot
5	6911FS	Blade, Ratchet	17	6962FS	Pin, Stop	31	6979FS	Guard, Spring
5A	6911FH	Blade, Ratchet (#6990FHL Only)	18	6966FS	Pin, Pivot	32	6905FSA*	Screw
6	6919FS	Pin, Pivot	19	697-FS	Guard, Spring	33	6906FSA*	Pin, Spring
7	6981FS	Knob, Release	20	6972FS	Screw	34	6937FSA	Guard, Spring
8	6921FS	Plate, Side	21	6973FS	Pin, Spring	35	6992FSS	Screw
8A	6921FH	Plate, Side (#6990FHL Only)	22	6977FS	Spring, Extension	36	6912FS	Pin, Spring
9	6927FS	Screw, Handle	23	6983FS	Ring	37	1487WM	Pin, Connecting

* Note: 6990TS ratchet cutter is the same as 6990FS in all respects except that it has tubular steel handles #6905TSA (32) and #6906TSA (33).
 6990FSL ratchet cutter is 19" long and has handles designated #6905FSL (32) and #6906FSL (33).
 6990FHL ratchet cutter is 19" long and has handles designated #6905FSLA (32) and #6906FSLA (33).

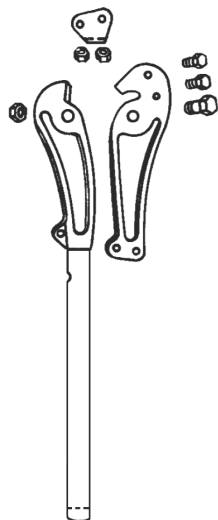

CUTTERHEAD ASSEMBLY
PART #
8613CK

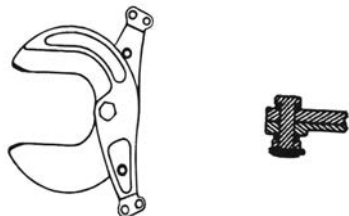
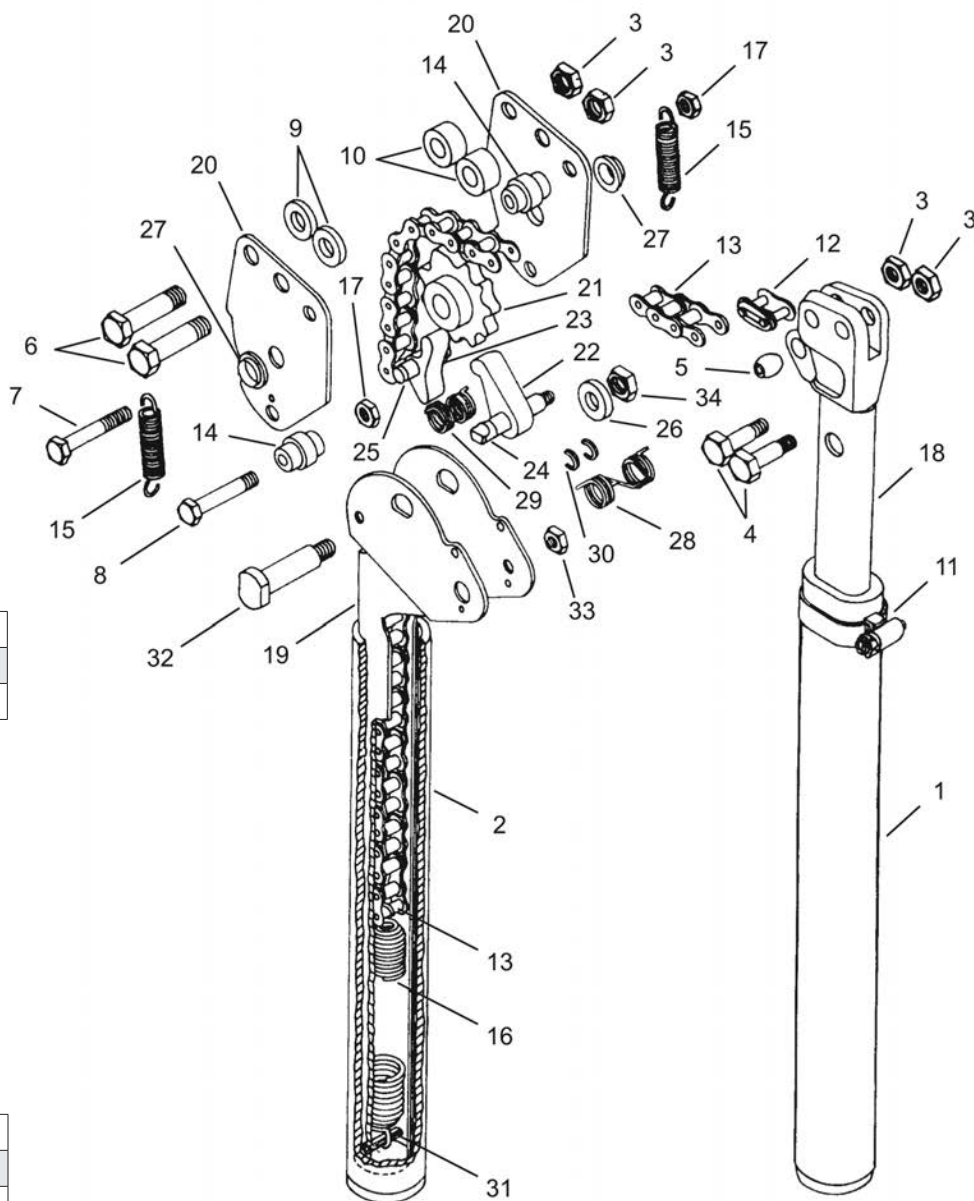

CUTTERHEAD ASSEMBLY
PART #
8613CS

Continued on page 389.

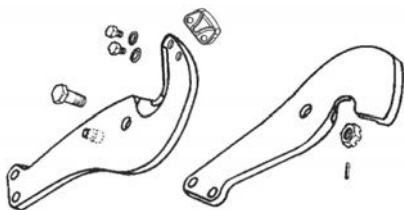

CUTTERHEAD ASSEMBLY
PART #
8613FH



CUTTERHEAD ASSEMBLY
PART #
8613FSK

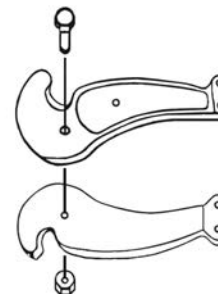

CUTTERHEAD ASSEMBLY
PART #
8613TN

8690 REPAIR PARTS

REF	QTY	MODEL NUMBER					DESCRIPTION
		8690CK	8690CS	8690FH	8690FSK	8690TN	
		OVERALL LENGTH					
		28" (711 MM)	29.75" (756 MM)	29.25" (748 MM)	27.5" (699 MM)	36" (914 MM)	
PART NUMBER							
1	1	P8681FH	P8681FH	P8681FH	P8681FH	P0380M	Handle Grip
2	1	P8680CK	P8680CK	P8680CK	P8680CK	P0380M	Handle Grip
3	4	P2666K	P2666K	P2666K	P2666K	P2666K	Nut (8690Ck: Qty. = 2)
4	2	-----	P0135SK	P0135SK	P0135SK	P0135SK	Bolt (Hex Head)
5	1	P8719CS	P8719CS	P8719CS	P8719CS	P8719CS	Bushing
6	2	P8628FS	P8628FS	P8628FS	P8628FS	P8628FS	Bolt (Hex Head)
7	1	P8634FS	P8634FS	P8634FS	P8634FS	P8634FS	Bolt
8	1	P8635FS	P8635FS	P8635FS	P8635FS	P8635FS	Bolt
9	2	-----	P8644FS	P8644FS	P8644FS	P8644FS	Spacer
10	2	-----	P8645FS	P8645FS	P8645FS	P8645FS	Spacer
11	1	P8648FS	-----	-----	-----	-----	Clamp
12	1	P8652FS	P8652FS	P8652FS	P8652FS	P8652FS	Chain Link
13	1	P8653FS	P8653FS	P8653FS	P8653FS	P8653TN	Chain
14	2	P8654FS	P8654FS	P8654FS	P8654FS	P8654FS	Snubber
15	2	P8658FH	P8658FH	P8658FH	P8658FH	P8658FH	Spring
16	1	P8678FS	P8678FS	P8678FS	P8678FS	P8678FS	Spring
17	2	T3171	T3171	T3171	T3171	T3171	Nut
18	1	8610CK	P8605F	P8605F	P8605F	P8605TN	Handle (Right)
--	--	P8661FH	P8661FH	P8661FH	P8661FH	P8661TN	Handle Assembly (Includes 18-33)
19	1	P8606FH	P8606FH	P8606FH	P8606FH	P8606TN	Handle (Left)
20	2	P8621FS	P8621FS	P8621FS	P8621FS	P8621FS	Side Plate
21	1	P8624FS	P8624FS	P8624FS	P8624FS	P8624FS	Sprocket
22	1	P8636FS	P8636FS	P8636FS	P8636FS	P8636FS	Pawl
23	1	P8637FS	P8637FS	P8637FS	P8637FS	P8637FS	Pawl
24	1	P8641FH	P8641FH	P8641FH	P8641FH	P8641FH	Pin
25	1	P8642FS	P8642FS	P8642FS	P8642FS	P8642FS	Bushing
26	1	P8644FS	P8644FS	P8644FS	P8644FS	P8644FS	Spacer
27	2	P8646FS	P8646FS	P8646FS	P8646FS	P8646FS	Bushing
28	1	P8674FS	P8674FS	P8674FS	P8674FS	P8674FS	Spring
29	1	P8677FS	P8677FS	P8677FS	P8677FS	P8677FS	Spring
30	2	P8683FH	P8683FH	P8683FH	P8683FH	P8683FH	Retainer
31	1	P8685FH	P8685FH	P8685FH	P8685FH	P8685FH	Pin
32	1	P8692FS	P8685FH	P8685FH	P8685FH	P8685FH	Bolt
33	1	T3171	T3171	T3171	T3171	T3171	Nut
34	1	P2666K	P2666K	P2666K	P2666K	P2666K	Nut

EDR-210 REPAIR PARTS

Continued on pages 391 - 393.

FIGURE 1		
ITEM #	PART #	DESCRIPTION
1	SB1065	Block (Parts 2-17)
2	A130000430	Cylinder
3	90016205022	Bolt 5 x 22
4	V100000080	Cylinder Gasket
5	P021001101	Piston Kit (Parts 6-9)
6	A101000000	Piston Ring
7	10001311520	Piston Pin
8	10001504630	Piston Pin Circlip
9	10001411520	Piston Pin Spacer
10	A011000101	Crankshaft (Includes 11)
11	V553000010	Needle Bearing
12	10020452130	Crankcase Kit (Parts 13-17)
13	10021242031	Oil Seal
14	10021503930	Dowel Pin
15	9403536201	Ball Bearing 6201
16	10024242030	Crankcase Gasket
17	90016205028	Bolt 5 x 28
18	10151421360	Cylinder Cover
19	90024204012	Screw 4 x 12
20	89016006361	Caution Label - HOT
21	X503003680	Model Label EDR-210
22	P021004810	Gasket Kit

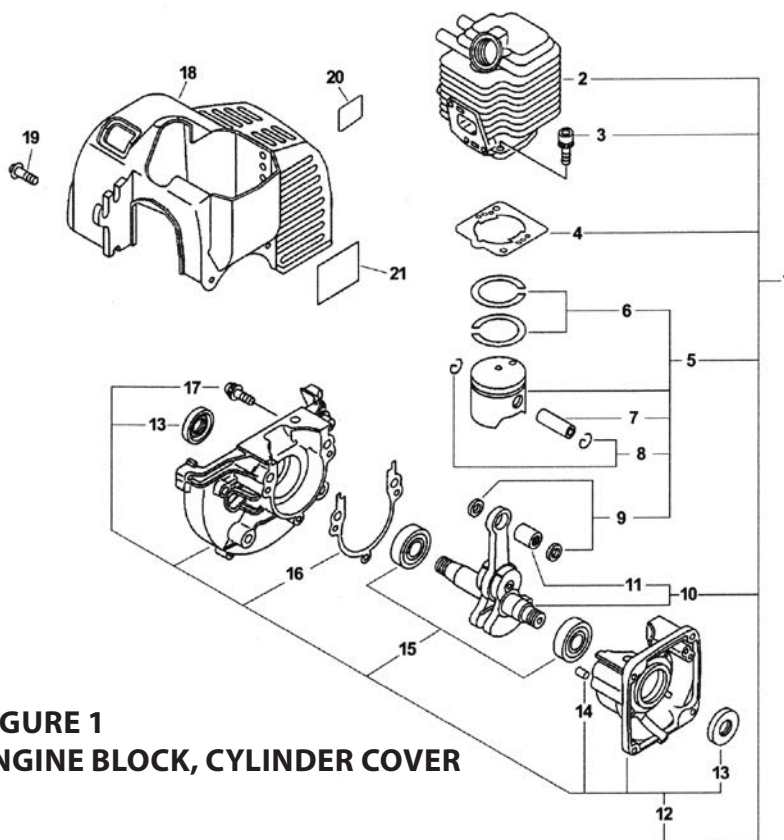

**FIGURE 1
ENGINE BLOCK, CYLINDER COVER**

**FIGURE 2
AIR FILTER, MUFFLER**

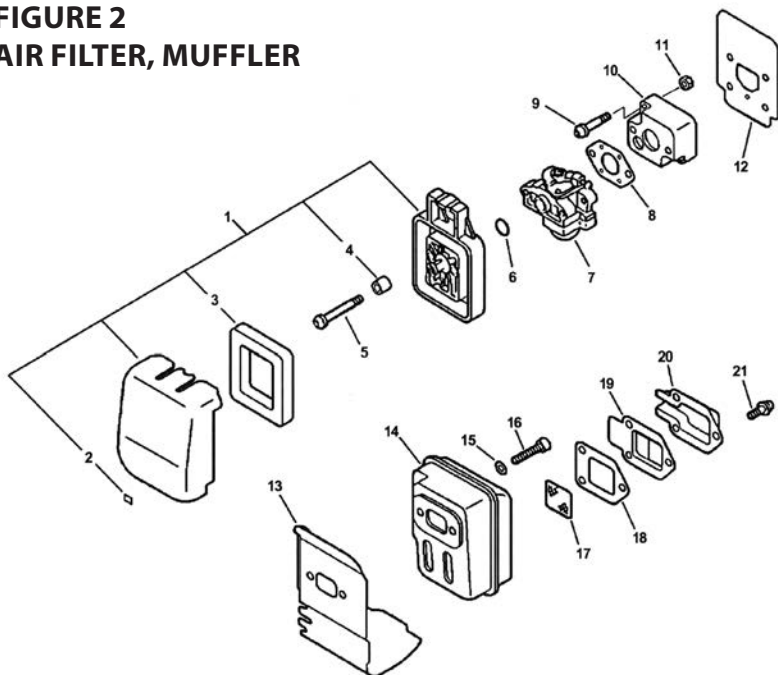
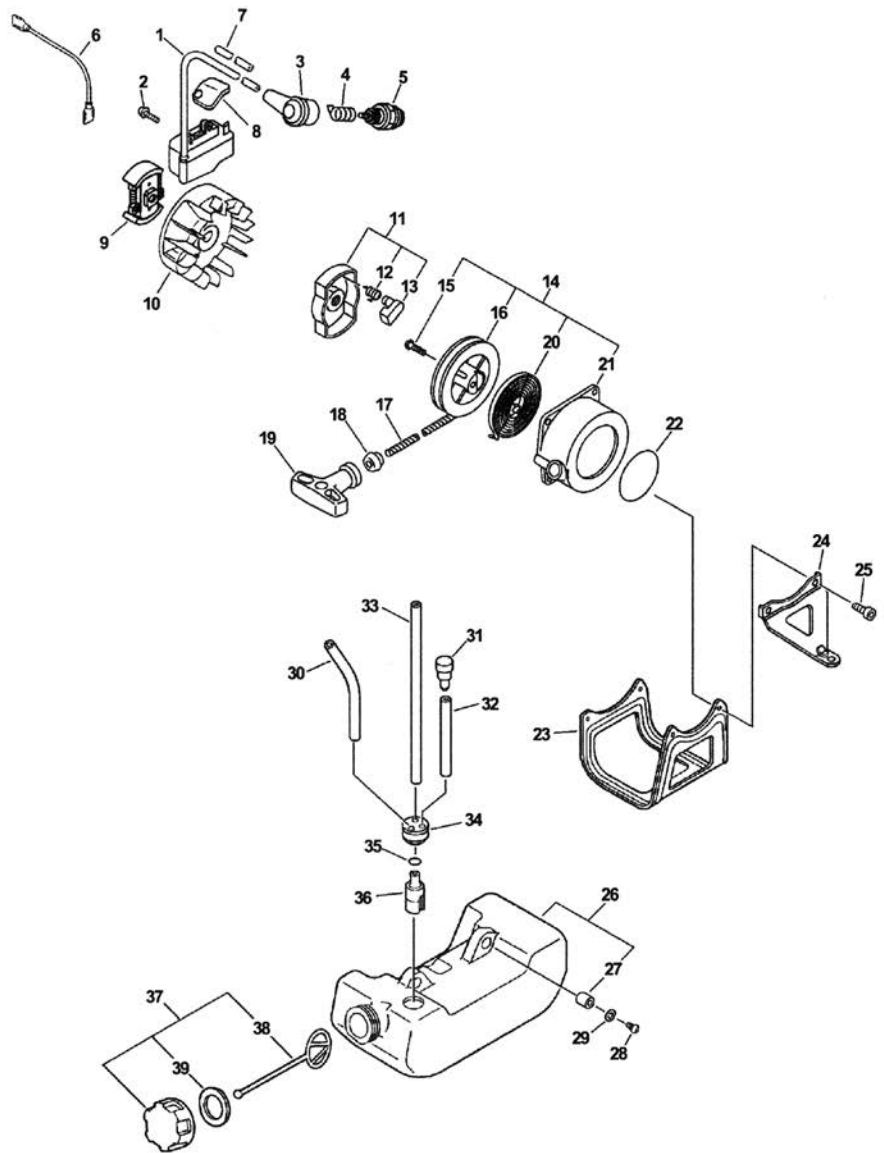

FIGURE 2		
ITEM #	PART #	DESCRIPTION
1	13030020960	Air Cleaner Assembly (Parts 2-4)
2	89099120960	Label
3	13031044330	Air Filter
4	13032744330	Sleeve
5	90024205064	Screw 5 x 64
6	90072000015	O-Ring 15
7	A021000541	Carburetor WYL-180A
8	13001044431	Intake Gasket
9	90024205020	Screw 5 x 20
10	13001744330	Insulator
11	90050000005	Nut 5
12	13001042032	Muffler Shield
13	14551044331	Cylinder Shield
14	14585805560	Muffler
15	90060000005	Washer 5
16	90010505055	Bolt 5 x 55
17	14586240630	Muffler Screen
18	V104000003	Exhaust Gasket
19	14587642030	Inner Exhaust Guide
20	A313000041	Outer Exhaust Guide
21	90024204010	Screw 4 x 10
22	P021004810	Gasket Kit

Continued on pages 392 & 393.

FIGURE 3 IGNITION, STARTER, CLUTCH, FUEL SYSTEM

FIGURE 3		
ITEM #	PART #	DESCRIPTION
1	A411000130	Ignition Coil
2	90016204020	Bolt 2 x 20
3	15901201620	Spark Plug Cap
4	15901103432	Spark Plug Cap Coil
5	15901019830	Spark Plug BPM-8Y
6	16201052830	Lead
7	15611054930	Tube
8	15011242030	Bushing
9	17500052130	Clutch Assembly
10	A409000160	Flywheel
11	17720244330	Starter Pawl Assembly (12-13)
12	17723442030	Return Spring
13	17721844331	Starter Pawl
14	17720042033	Starter Assembly (Parts 15-21)
15	17723644330	Screw
16	17721544430	Starter Drum
17	17622610120	Starter Rope
18	17722742030	Rope Guide
19	17722806530	Starter Grip
20	17722042030	Rewind Spring
21	17723242032	Starter Label
22	89011849130	Label ECHO
23	30511042030	Stand
24	35101105560	Rear Handle Support
25	90016204016	Bolt 4 x 16
26	13100544332	Fuel Tank (Includes 27)
27	13104528230	Collar
28	90024305016	Screw 5 x 16
29	90060300005	Washer 5
30	13201256030	Return Pipe
31	13130056430	Check Valve
32	13131205560	Vent Pipe
33	13201005560	Fuel Pipe
34	13211546730	Fuel Grommet
35	13201309820	Clip
36	13120507320	Fuel Strainer
37	13100455530	Fuel Cap Assembly (38-39)
38	13105152430	Fuel Cap Connector
39	13101655830	Fuel Cap Gasket



EDR-210 REPAIR PARTS

Continued on page 393.

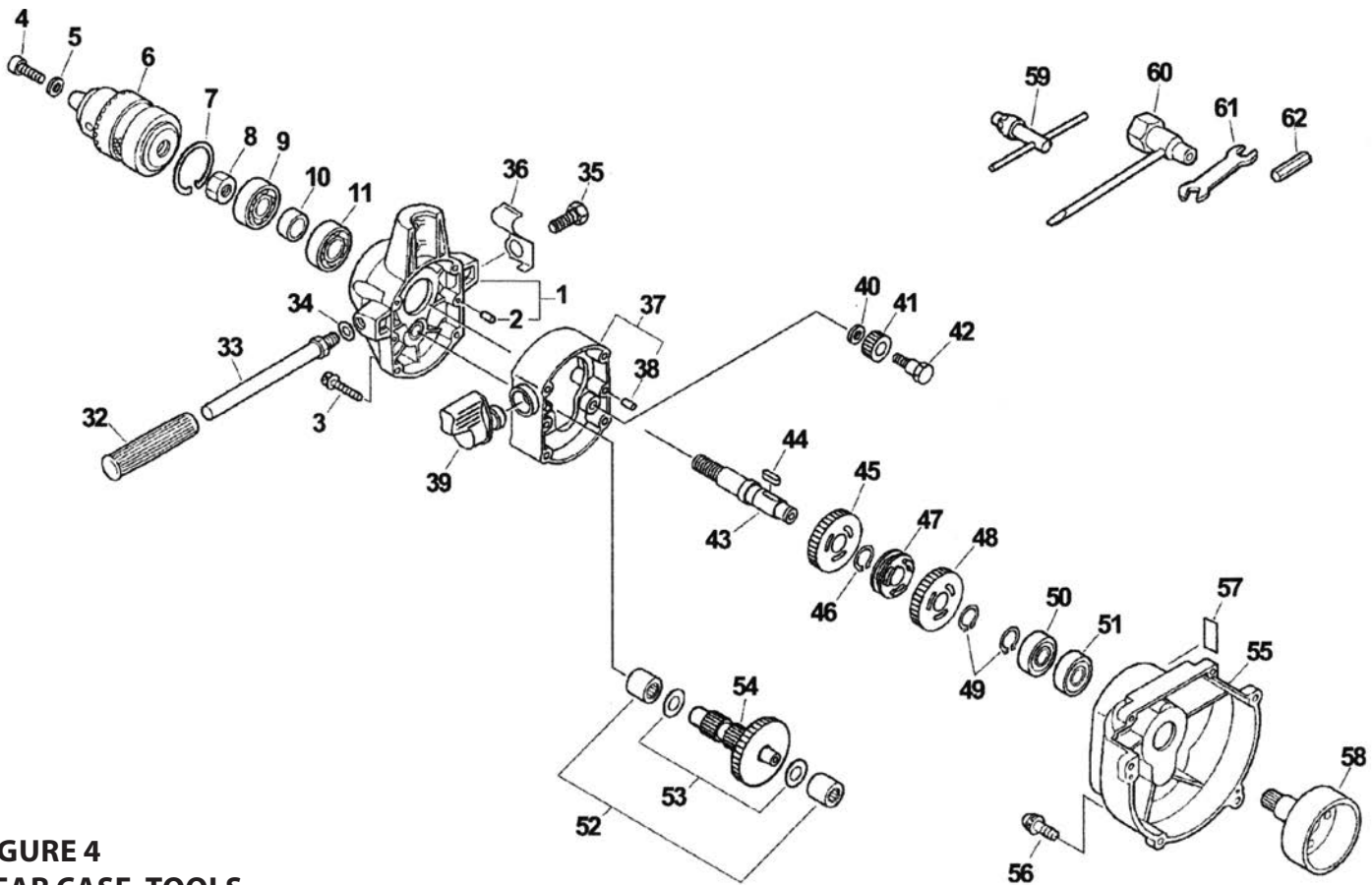
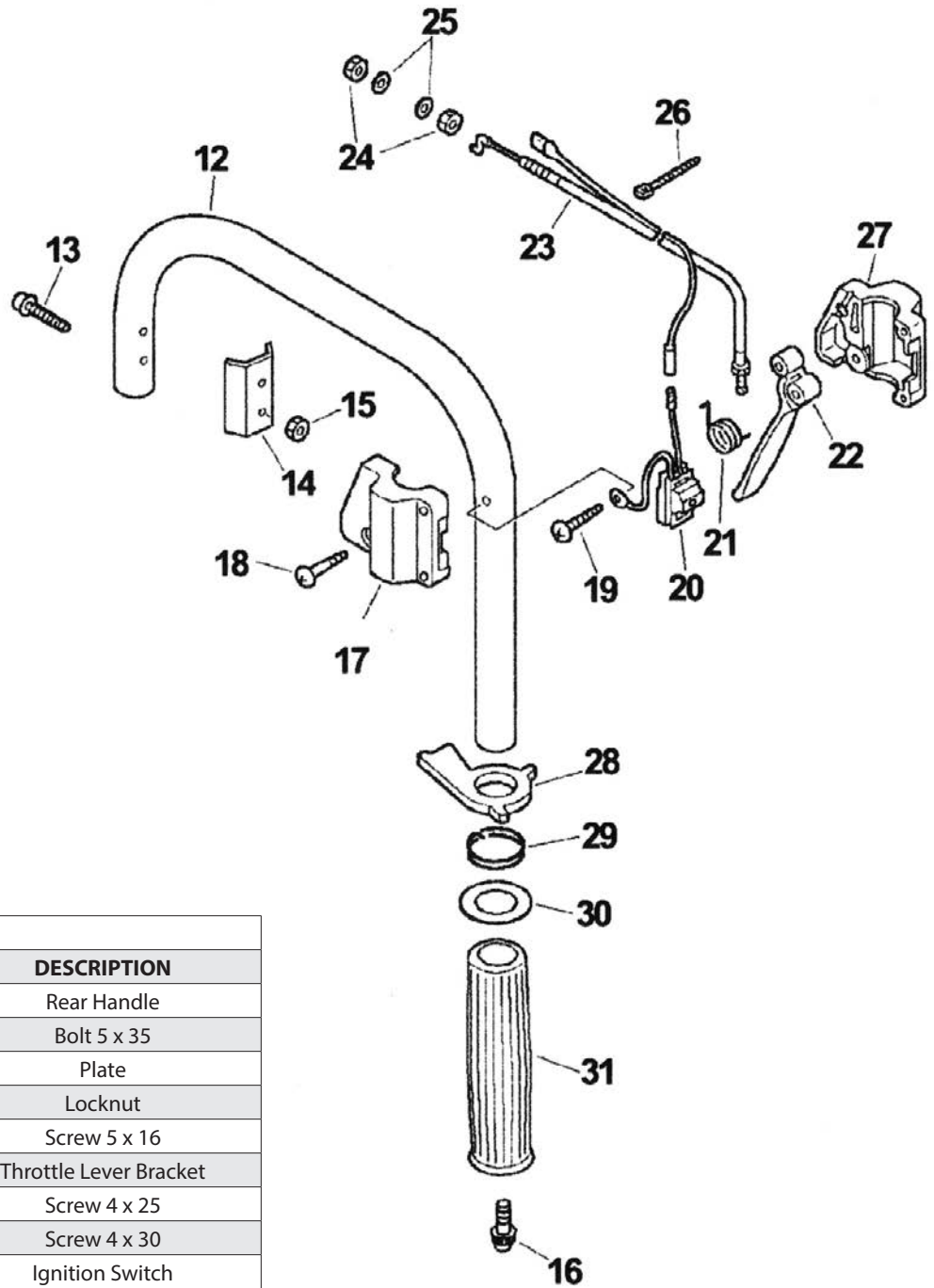

FIGURE 4
GEAR CASE, TOOLS

FIGURE 4

ITEM #	PART #	DESCRIPTION	ITEM #	PART #	DESCRIPTION
1	60430520960	Gear Housing (Includes 2)	42	17504622332	Clutch Bolt
2	10021503930	Dowel Pin	43	60602120960	Axle Shaft
3	90016205050	Bolt 5 x 50	44	90032504016	Woodruff Key
4	90010506020	Bolt 6 x 20	45	60421320960	Spur Gear
5	17501404630	Washer	46	90070100015	Circlip 15
6	60405105560	Chuck	47	60423520960	Clutch Dog
7	90070200032	Circlip 32	48	60422420960	Spur Gear
8	22431920960	Nut 12	49	90070100012	Circlip 12
9	90080206002	Ball Bearing 6002	50	90080006001	Ball Bearing 6001
10	60404405560	Collar	51	90080106001	Ball Bearing 6001
11	90080036002	Ball Bearing 6002	52	60422105560	Bearing
32	35151522330	Grip	53	60422305560	Washer
33	35121005560	Side Handle	54	60420620961	Gear with Shaft
34	90060000010	Washer 10	55	10151120960	Fan Cover
35	90010010015	Bolt 10 x 15	56	90024204016	Screw 4 x 16
36	89757505560	Chuck Key Holder	57	89019405560	Caution Label-HOT
37	60430620960	Gear Case (Includes 38)	58	17500505560	Clutch Drum
38	10021503930	Dowel Pin	59	89757005560	Chuck Key
39	70300520960	Clutch Lever	60	89541039130	Wrench / Screwdriver
40	17501404630	Washer	61	8912220960	Spanner
41	60531120960	Spur Gear	62	89541220960	Tool Bar



**FIGURE 5
HANDLE, THROTTLE CONTROL**

FIGURE 5		
ITEM #	PART #	DESCRIPTION
12	35130520960	Rear Handle
13	90016205035	Bolt 5 x 35
14	35164105560	Plate
15	90026000005	Locknut
16	90024205016	Screw 5 x 16
17	17805201260	Throttle Lever Bracket
18	90024504025	Screw 4 x 25
19	90024504030	Screw 4 x 30
20	16340004460	Ignition Switch
21	17804301260	Throttle Return Spring
22	17801007660	Throttle Trigger
23	17810009060	Control Cable Assembly
24	90050200006	Nut 6
25	90060000006	Washer 6
26	17812156030	Band
27	17802401260	Throttle Bracket
28	17801202061	Throttle Lockout
29	17801302060	Throttle Lockout Spring
30	17807002061	Spacer
31	35131527930	Handle Grip

Continued on pages 395 - 397.

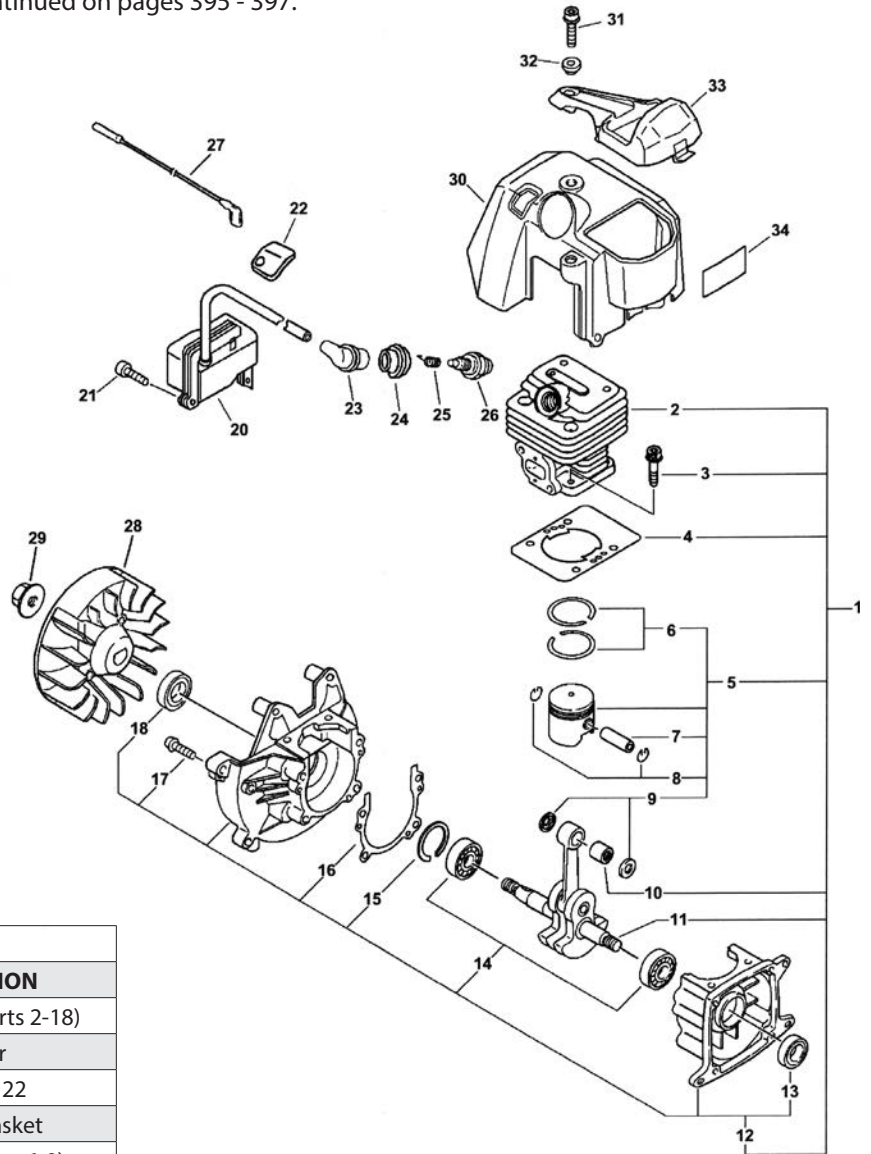

FIGURE 1
ENGINE BLOCK,
IGNITION, CYLINDER COVER

FIGURE 1		
ITEM #	PART #	DESCRIPTION
1	SB1060	Short Block (Parts 2-18)
2	A130000371	Cylinder
3	90016205022	Screw 5 x 22
4	V100000070	Cylinder Gasket
5	P021004740	Piston Kit (Parts 6-9)
6	A101000010	Piston Ring
7	V606000000	Piston Pin
8	10001504630	Piston Clip Circlip
9	10001455930	Piston Pin Spacer
10	V553000020	Needle Bearing
11	A011000030	Crankshaft Assembly
12	P021000940	Crankcase Kit (Parts 13-18)
13	10021305530	Oil Seal
14	90080036001	Ball Bearing
15	90070200028	Circlip 28
16	10024255930	Crankcase Gasket
17	90016205025	Screw 5 x 25
18	10021228230	Oil Seal
19	P021003970	Gasket Kit
20	A411000110	Ignition Coil
21	90016205016	Bolt 5 x 16
22	15011242030	Grommet

FIGURE 1 CONTINUED		
ITEM #	PART #	DESCRIPTION
23	A427000010	Spark Plug Cap
24	A4290000000	Spark Plug Cap Cover
25	A426000010	Spark Plug Cap Terminal
26	15901019830	Spark Plug BPM-8Y
27	16201056430	Ground Lead
28	A409000130	Flywheel
29	90051500008	Flange Nut 8
30	A160000471	Cylinder Cover
31	9111005016	Screw 5 x 16
32	V3530000020	Collar 5
33	A161000060	Air Duct
34	X503004600	Label EDR-260

FIGURE 2

ITEM #	PART #	DESCRIPTION
1	21041752370	Wing Bolt
2	13031306563	Air Cleaner Lid
3	89012152730	Label Choke
4	13031054130	Air Filter
5	90024205060	Screw 5 x 60
6	12901152730	Plate Prevent
7	P021000991	Air Cleaner Case
8	A021000670	Carburetor WYJ-330
9	13001013410	Intake Gasket
10	90016205025	Screw 5 x 25
11	13001756431	Insulator
12	13001055930	Intake Gasket
13	V104000061	Exhaust Shield
14	14585805560	Muffler
15	90060300005	Washer
16	90010505055	Screw 5 x 55
17	14586240630	Muffler Screen
18	V1040000003	Exhaust Gasket
19	14587642030	Inner Exhaust Guide
20	A313000041	Outer Exhaust Guide
21	90024204010	Screw 4 x 10
22	A320000220	Muffler Cover
23	90010605012	Screw 5 x 12
24	89016006361	Label Caution Hot
25	P021003970	Gasket Kit

**FIGURE 2
AIR FILTER, MUFFLER**

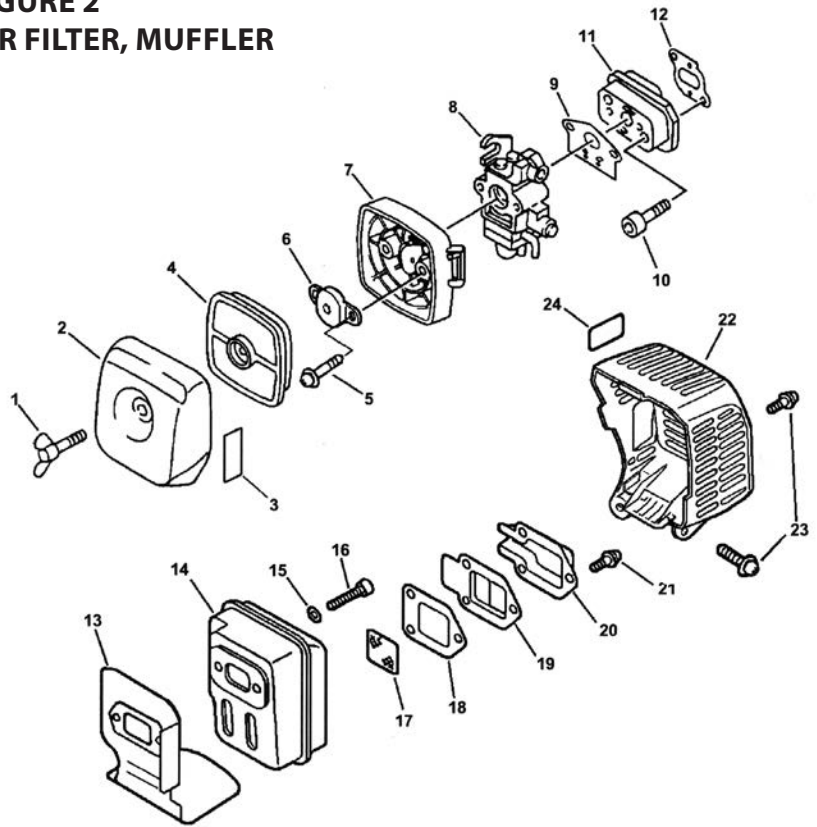
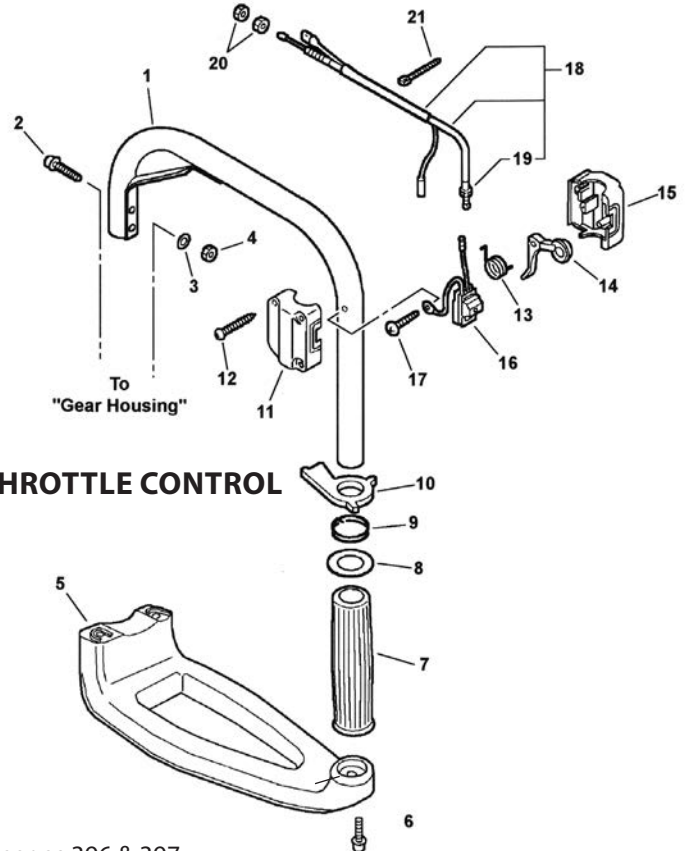

FIGURE 3

Item #	PART #	Description
1	C410000160	Rear Handle
2	90016205035	Screw 5 x 35
3	90060200005	Washer
4	90056000005	Locknut
5	A175000021	Stand
6	9111005016	Screw 5 x 16
7	35131527930	Rear Handle Grip
8	17807002061	Spacer
9	17801302060	Throttle Lock Spring
10	17801202061	Throttle Lockout
11	17805201261	Left Throttle Lever Bracket
12	90024504025	Screw 4 x 25
13	17804301260	Throttle Return Spring
14	C450000150	Throttle Trigger
15	17802401261	Right Throttle Lever Bracket
16	16340004460	Ignition Switch
17	90024504030	Screw 4 x 30
18	V043000010	Throttle Cable Assembly
19	90050200006	Nut 6
20	90050200006	Nut 6
21	17812156030	Band

**FIGURE 3
HANDLE, THROTTLE CONTROL**



Continued on pages 396 & 397.

EDR-260 REPAIR PARTS

**FIGURE 4
CLUTCH, STARTER, FUEL SYSTEM, TOOLS**

Item #	PART #	Description
1	17504656030	Clutch Shaft
2	17504956030	Washer
3	A553000010	Clutch Shoe
4	V451000090	Tension Spring
5	17504805530	Washer
6	17720240630	Starter Pawl Assembly (Parts 7-9)
7	90070000004	E-Ring 4
8	17723440630	Return Spring
9	17721840630	Starter Pawl
10	90050200008	Nut 8
11	17720055931	Starter Assembly (Parts 12-18)
12	17723644330	Screw
13	17721540630	Starter Drum
14	17722603930	Starter Rope
15	17722742030	Rope Guide
16	17722827030	Starter Grip
17	17722040630	Rewind Spring
18	90056500005	Nut
19	90016204014	Screw 4 x 14
20	89011849130	Label ECHO
21	A350000111	Fuel Tank (Includes 22)
22	13104528230	Spacer
23	90060300005	Washer 5
24	90023905016	Bolt 5 x 16
25	13201256030	Return Pip
26	V471000110	Vent Pipe
27	13201326630	Clip
28	A356000030	Vent Assembly
29	13201052030	Fuel Pipe
30	13211555930	Fuel Grommet
31	13120519830	Fuel Filter
32	13100455530	Tank Cap (Includes 33, 34)
33	13101655830	Fuel Cap Gasket
34	13105156030	Fuel Cap Connector
35	89541039130	Wrench / Screwdriver
36	89512220960	Spanner
37	89541220960	Tool Bar

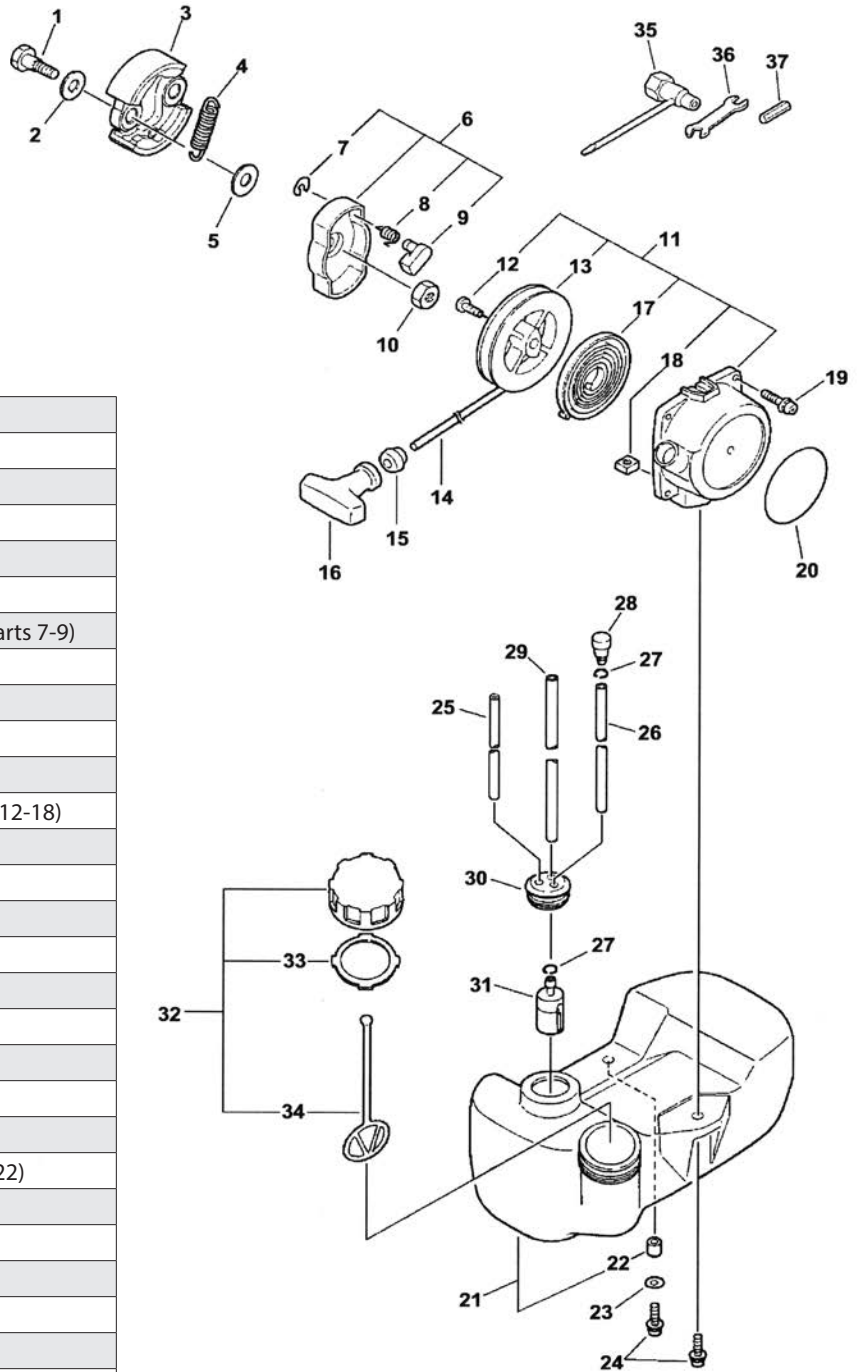

Continued on page 397.

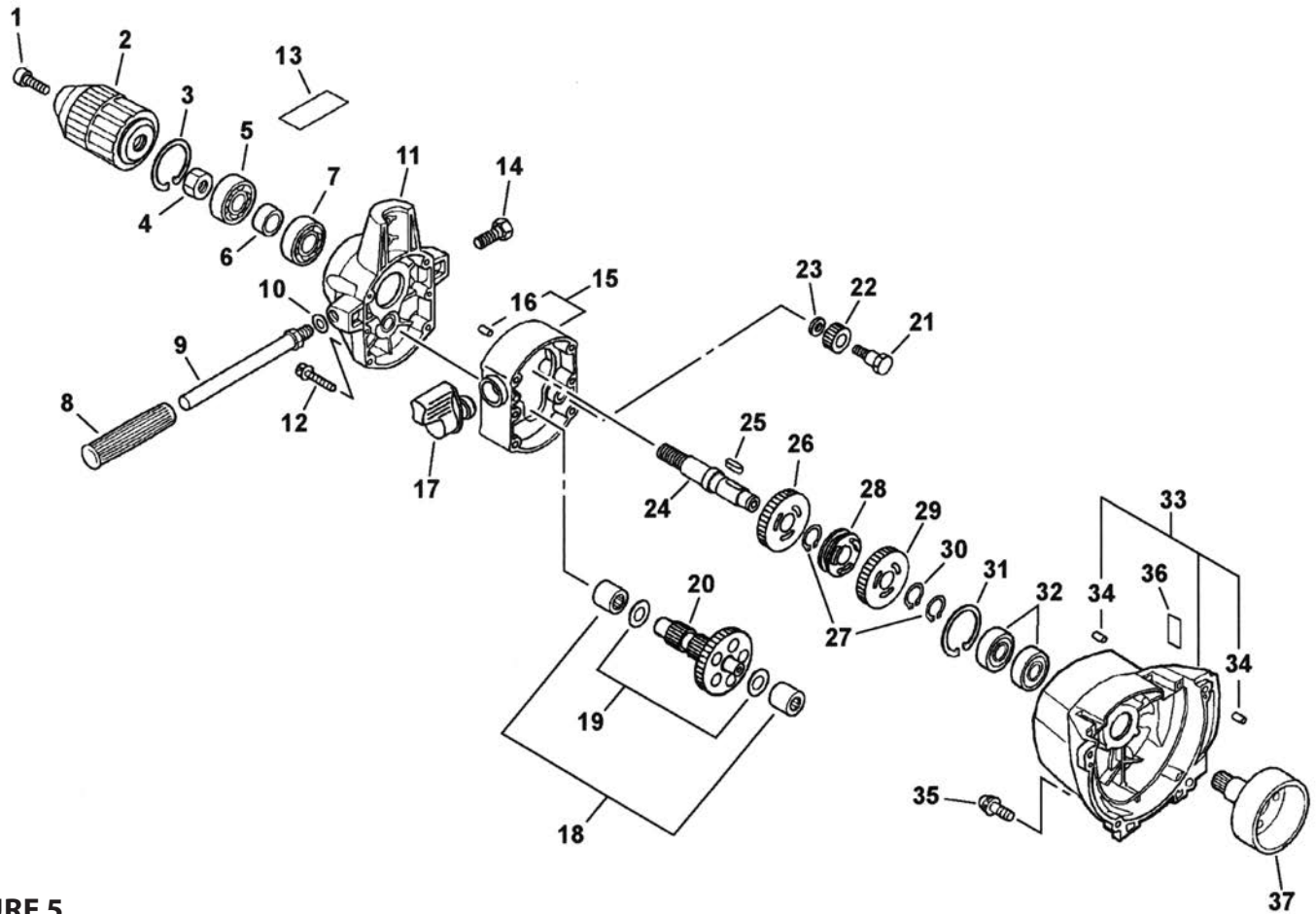
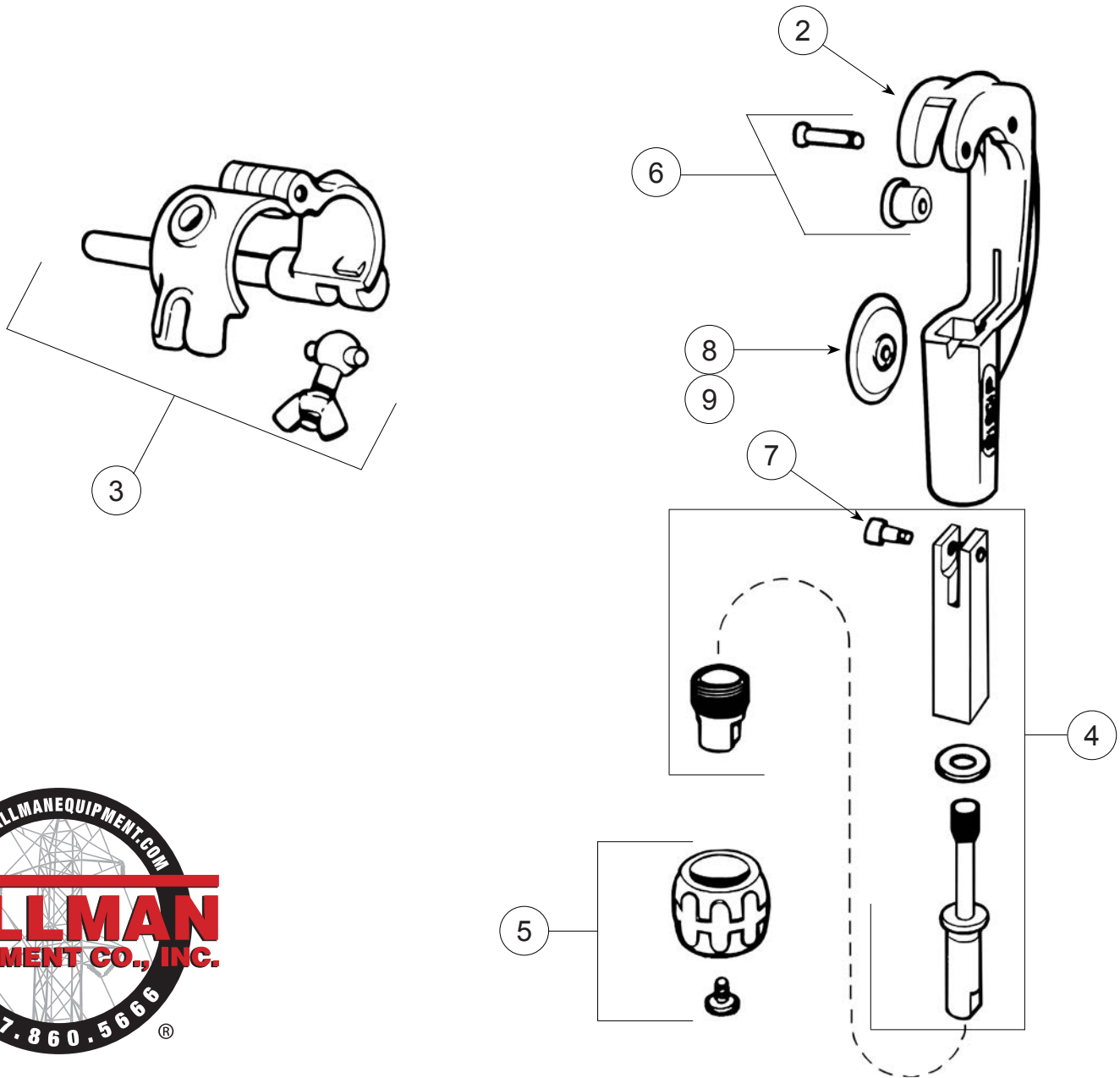

FIGURE 5
GEAR CASE, CLUTCH DRUM

ITEM #	PART #	DESCRIPTION	ITEM	PART #	DESCRIPTION
1	9110306020	Bolt 6 x 20	20	P021005820	Gear with Shaft
2	99944900320	Keyless Chuck	21	V204000070	Clutch Bolt
3	90070200032	Circlip 32	22	V650000150	Spur Gear
4	22431920960	Nut 12	23	V305000020	Washer
5	90080206002	Ball Bearing	24	60602120960	Axle Shaft
6	60404405560	Collar	25	90032504016	Feather Key 4 x 16
7	90080036002	Ball Bearing	26	V650000130	Spur Gear
8	35151522330	Grip	27	90070100015	Circlip 15
9	P021002700	Left Handle	28	P021005840	Clutch Adjuster Cam
10	90060000010	Washer 10	29	V650000140	Spur Gear
11	C531000181	Gear Housing	30	90070100012	Circlip 12
12	90016205050	Screw 5 x 50	31	90070200032	Circlip 32
13	89016006361	Label CAUTION-HOT	32	90080106002	Ball Bearing
14	90010010015	Bolt 10 x 15	33	P021005831	Fan Cover
15	P021005801	Gear Case Assembly (Includes 16)	34	10021503930	Dowel Pin
16	V622000020	Dowel Pin	35	90024205018	Screw 5 x 18
17	70300520960	Clutch Lever	36	89019405560	Label CAUTION
18	60422105560	Bearing	37	A556000250	Clutch Drum
19	60422305560	Washer			

PSC-1 REPAIR PARTS



ITEM #	PART #	DESCRIPTION	QTY
1	DN54140	Plastic Carrying Case (Not Shown)	1
2	DN54145	Cutter Frame	1
3	DN54160	Bushing Holder Assembly	1
4	DN54165	Bar & Feed Screw Assembly	1
5	DN34625	Knob Assembly	1
6	DN54285	Roller & Roll Pin Set, 1 Each	2
7	DN54305	Cutter Wheel Axle	1
8	DN54270	Cutter Wheel	1

TE200 REPAIR PARTS

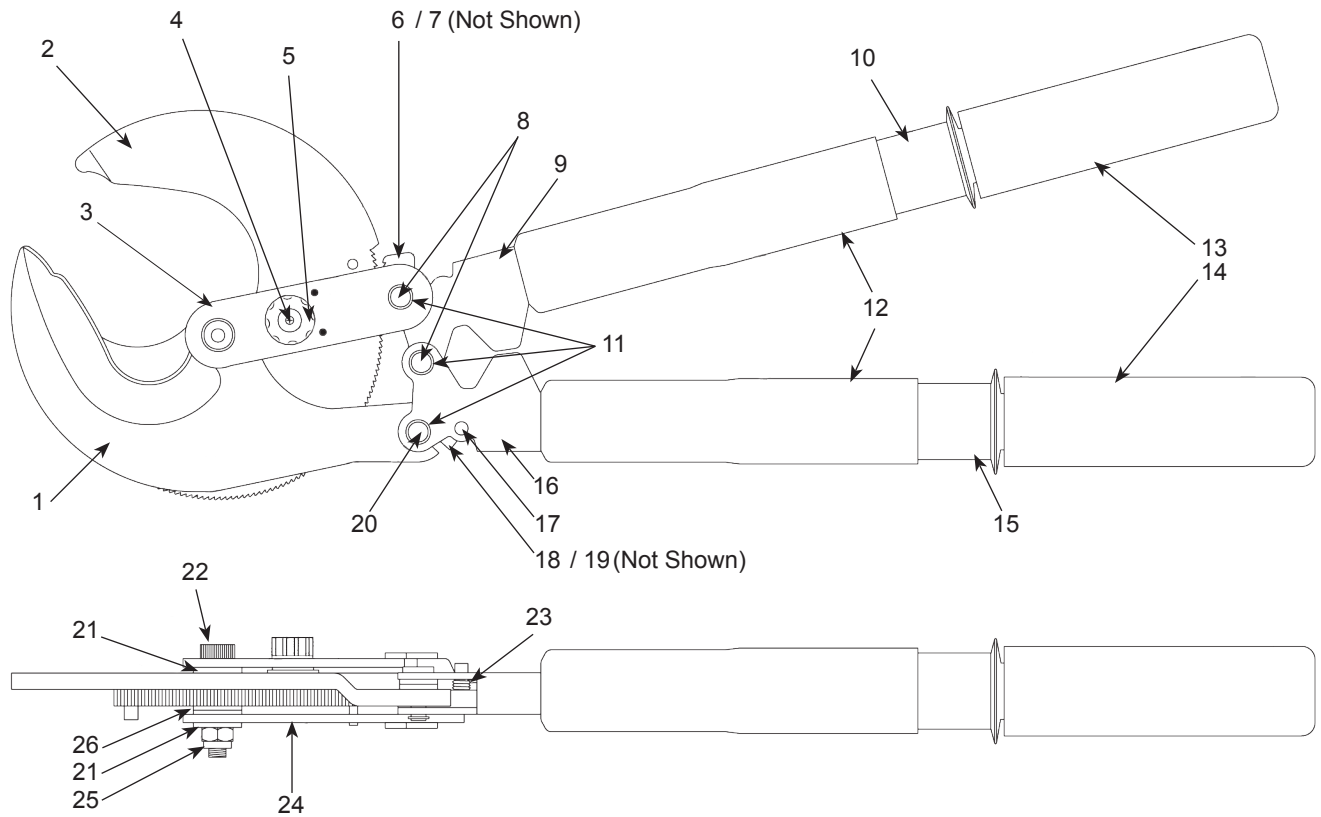

* Torque locknut A007601 to 180 - 220 In-lbs.

ITEM #	PART #	DESCRIPTION
1	C701302	Fixed Jaw
2	C701402	Moveable Jaw
3	C710102	Top Link Assembly
4	A701301	Switch Screw
5	C706101	Direction Knob Assembly
6	C804401	Pawl
7	C804201	Pawl Bracket
8	A015101	Pin, 5/16 x 1.10
9	C711001	Right Handle Assembly
10	C704801	Right Cuff
11	A015301	Retaining Ring (6)
12	A027515	Cover (2)
13	A025001	Inner Grip

ITEM #	PART #	DESCRIPTION
14	A025201	Outer Grip
15	C704901	Left Cuff
16	C710301	Left Handle Assembly
17	A703501	Latch Pin
18	C703401	Latch
19	C703601	Latch Rod
20	A015103	Pin, 5/16 x .825
21	B703201	Shoulder Washer (2)
22	A004701	Socket Shoulder Screw
23	A710901	Latch Spring
24	C711501	Bottom Link
25	A007601	Locknut, 5/16
26	A711401	Washer

TE556 REPAIR PARTS

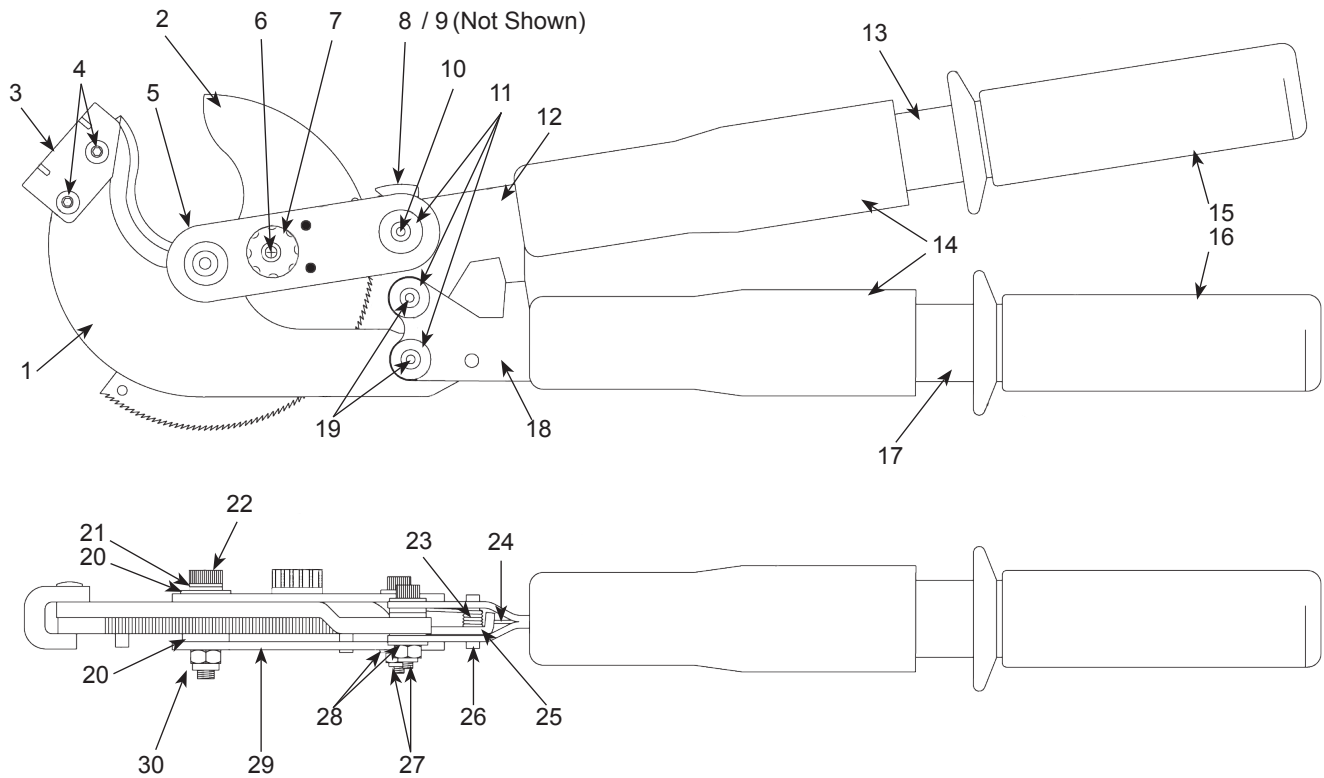

* Torque locknut A007601 to 180 - 220 In-lbs.

* Torque all 3 locknuts A008201 to 20 - 30 In-lbs.

ITEM #	PART #	DESCRIPTION
1	C705501	Fixed Jaw
2	C705601	Moveable Jaw
3	C705701	Stiffener
4	A700701	Stiffener Screw (2)
5	C702302	Top Link Assembly
6	A701301	Switch Screw
7	C706101	Direction Knob
8	C704401	Pawl
9	C704201	Pawl Bracket
10	A006801	Socket Shoulder Screw, 1/4 x 1
11	A000401	Washer, 1/4 x .05 (4)
12	C705301	Right Handle Assembly

ITEM #	PART #	DESCRIPTION
16	A025201	Outer Grip
17	C704901	Left Cuff
18	C705201	Left Handle Assembly
19	A006901	Socket Shoulder Screw, 1/4 x 3/4
20	B703201	Shoulder Washer (2)
21	A000601	Washer, 3/8 x .05 (2)
22	A004701	Socket Shoulder Screw, 3/8 x 1
23	A703701	Latch Spring
24	C703601	Latch Rod
25	C703401	Latch
26	A703501	Latch Pin
27	A008201	Locknut, 10-24 (3)
28	A001901	Washer, .260 x .08 (4)
29	C702201	Bottom Link
30	A007601	Locknut, 5/16

DNAB-1 REPAIR PARTS

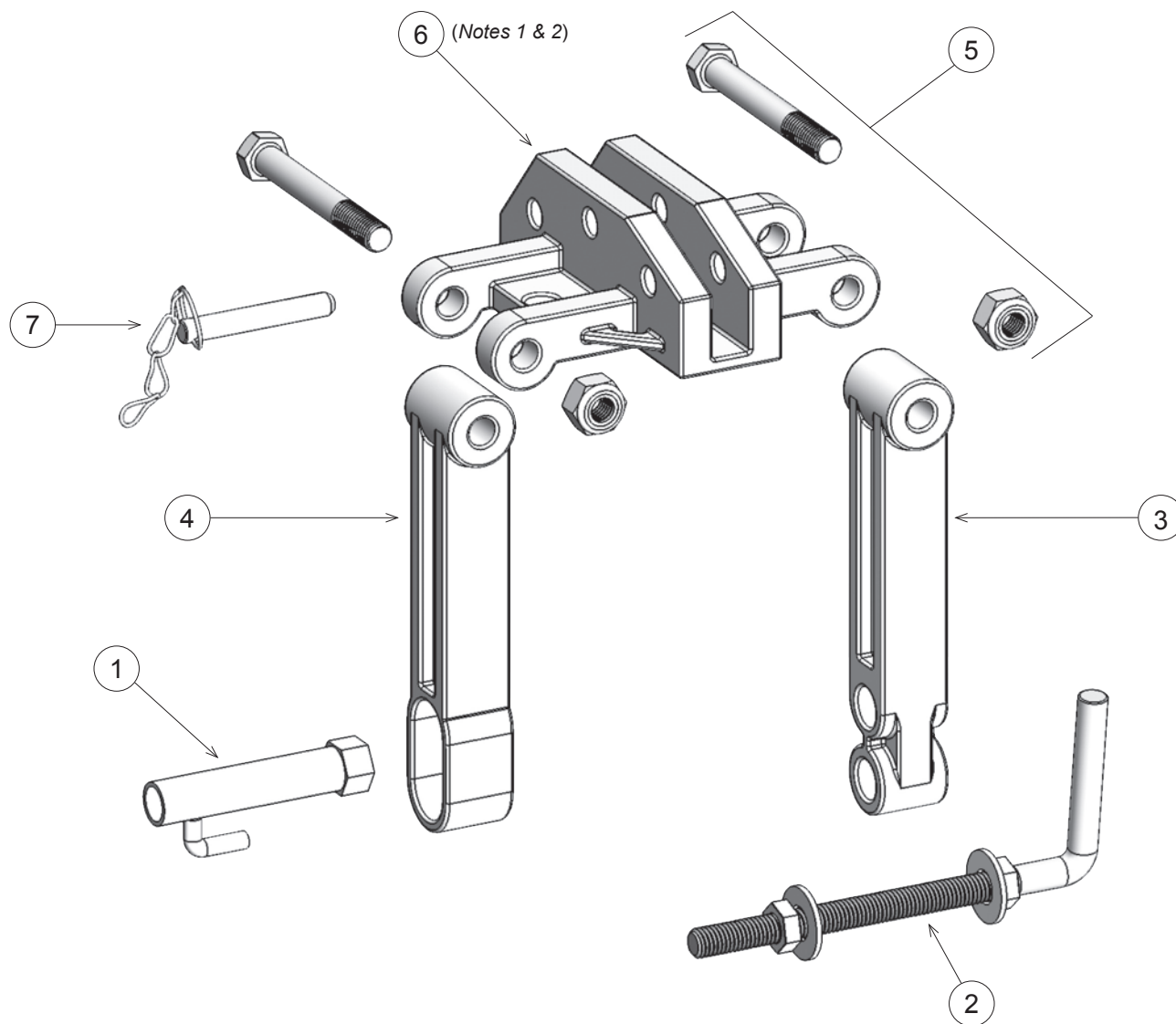

ITEM:	DNAB-1
DESCRIPTION	CROSSARM BRACKET
DATE:	APRIL, 2011

ITEM #	PART #	DESCRIPTION	QTY.
1	DN6AK-1	Hook Nut	1
2	DN6AK-2	L-Screw, Washers & Nut	1
3	DN6AK-3	Male Arm	1
4	DN6AK-4	Female Arm	1
5	DN6AK-5	Arm Bolt & Nut	2
6	DN6AK-6	Bracket Base	1
7	DN6AK-7	Detent Pin, Chain & Ring	1

DNAB-2 REPAIR PARTS

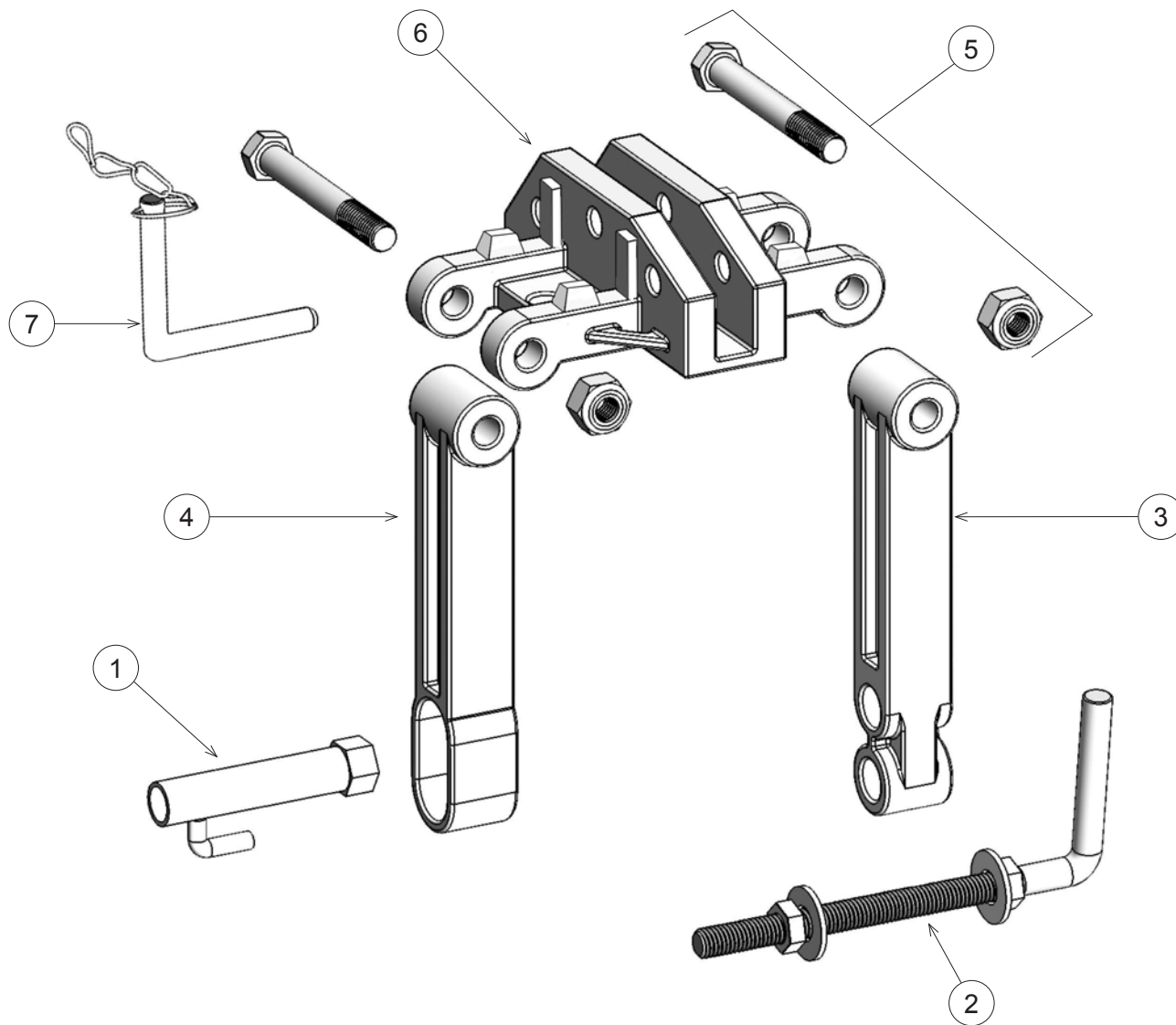

ITEM:	DNAB-2
DESCRIPTION:	CROSSARM BRACKET
DATE:	JUNE, 2012

ITEM #	PART #	DESCRIPTION	QTY.
1	DN6AK-1	Hook Nut	1
2	DN6AK-2	L-Screw, Washers & Nut	1
3	DN6AK-3	Male Arm	1
4	DN6AK-4	Female Arm	1
5	DN6AK-5	Arm Bolt & Nut	2
6	DN6AK-6-2	Bracket Base	1
7	DN6AK-7-2	Detent Pin, Chain & Ring	1

DNCB-1 7" REPAIR PARTS

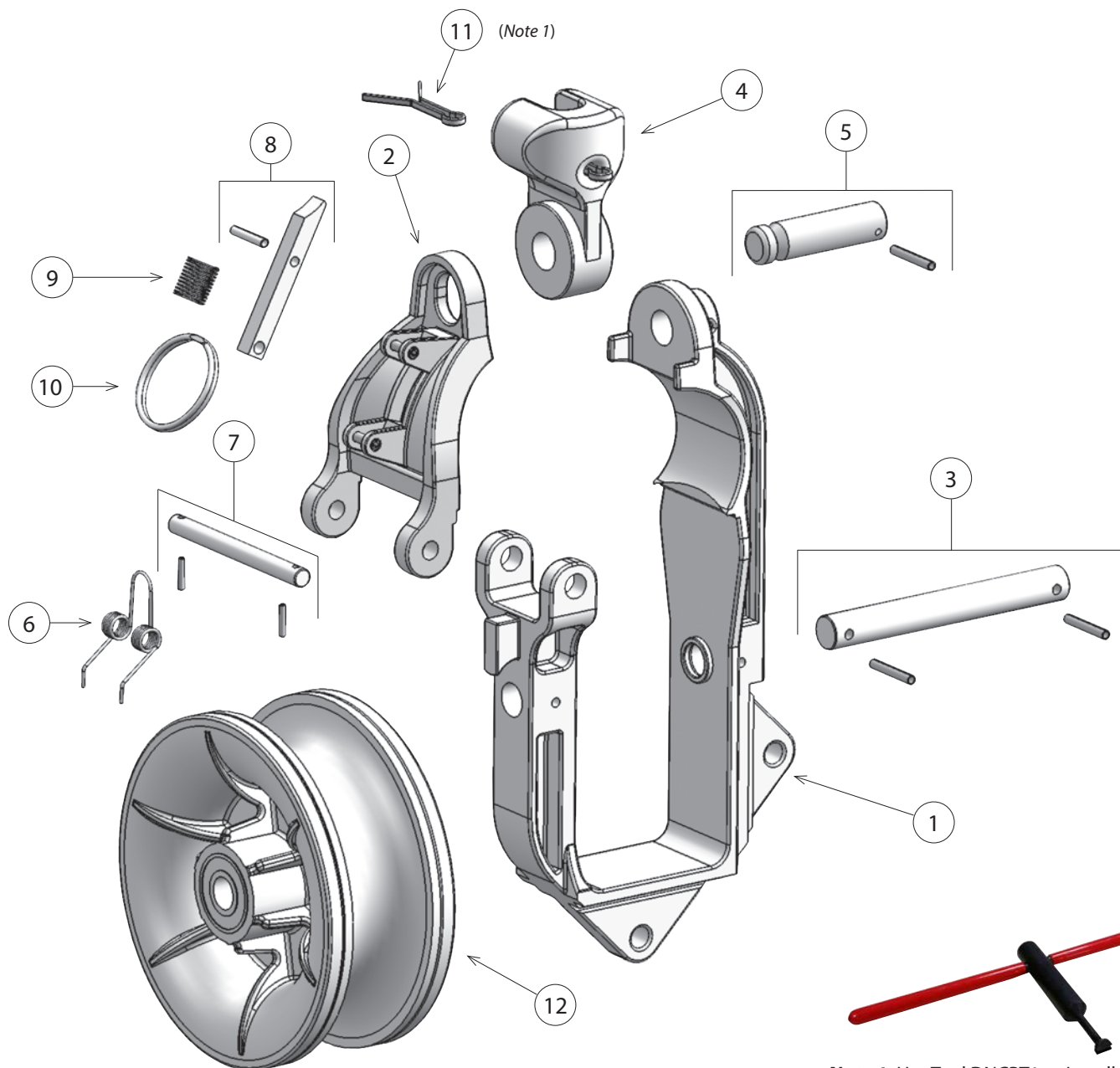

Note 1: Use Tool DNCPT1 to Install Cotter Pin

ITEM #	PART #	DESCRIPTION	QTY.
1	DNCB-1-105	Lower Frame	1
2	DNCB-1-110	Frame Gate & Roll Pins	1
3	DNCB-1-115	Axle & Roll Pin	1
4	DNCB-1-120	Socket Eye & Cotter Pin	1
5	DNCB-1-125	Goathead Pin & Roll Pin	1
6	DNCB-1-130	Gate Pin Spring	1
7	DNCB-1-135	Gate Pin & Roll Pins	1
8	DNCB-1-140	Square Keeper & Roll Pin	1
9	DNCB-1-145	Spring for Square Keeper	1
10	DNCB-1-150	Ring for Square Keeper	1
11	DNCP1	Cotter Pin	1

ITEM:	DNCB-1
DESCRIPTION	7" UNIVERSAL STRINGING BLOCK
DATE:	April, 2011

ITEM #	PART #	DESCRIPTION	QTY.
12	DNCB-7A	Aluminum Sheave	1
12	DNCB-7L	Urethane Lined Alum Sheave	1
12	DNCB-7DI	Ductile Iron Sheave	1

All Sheaves are supplied with bearings installed.

DNCB-2 7" REPAIR PARTS

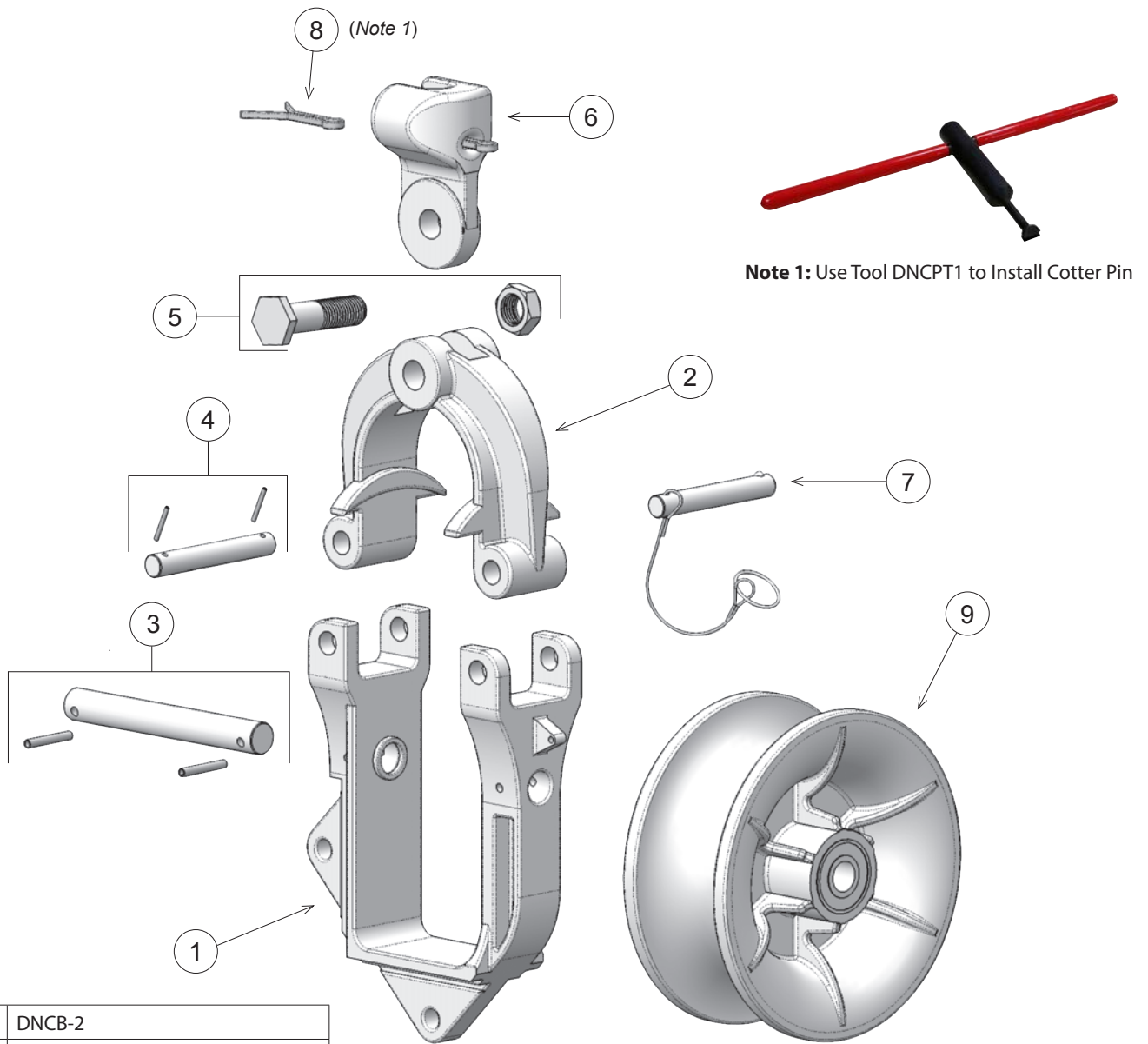

ITEM:	DNCB-2
DESCRIPTION:	7" UNIVERSAL STRINGING BLOCK
DATE:	April, 2011

ITEM #	PART #	DESCRIPTION	QTY.
1	DNCB-2-205	Lower Frame	1
2	DNCB-2-210	Upper Frame	1
3	DNCB-1-115	Axle & Roll Pin	1
4	DNCB-2-220	Hinge Pin & Roll Pins	1
5	DNCB-2-225	Hex Bolt & Nut	1
6	DNCB-2-230	Socket Eye & Cotter Pin	1
7	DNCB-2-235	Detent Pin Assembly	1
8	DNCP1	Cotter Pin	1
9	DNCB-7A	Aluminum Sheave	1
9	DNCB-7L	Urethane Lined Aluminum Sheave	1
9	DNCB-7DI	Ductile Iron Sheave	1

All sheaves are supplied with bearings installed.

DNRB3222 REPAIR PARTS

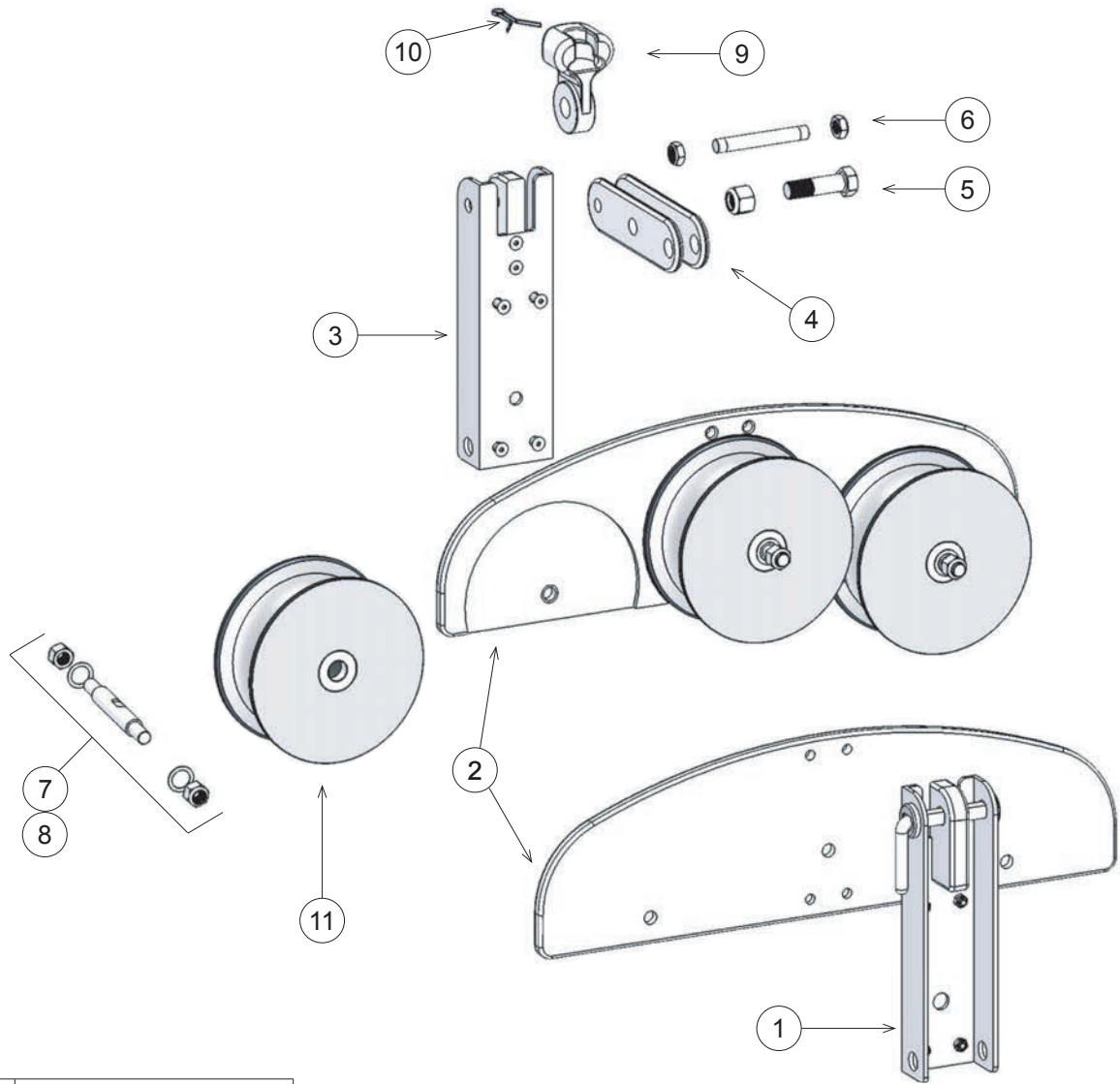

ITEM:	DNRB3222
DESCRIPTION:	RADIUS BLOCK, 3 ROLLER
DATE:	July, 2011

ITEM #	PART #	DESCRIPTION	QTY.
1	DNRB3222-205	Locking Channel with Mounting Hardware	1
2	DNRB3222-210	Side Plate	2
3	DNRB3222-215	Pivot Channel with Mounting Hardware	1
4	DNRB3222-220	Hanger Bars, Set of 2	2
5	DNRB3222-225	Machine Bolt & Nut	1
6	DNRB3222-230	Pivot Axle & Nuts	1
7	DNRB3222-235	Outer Roller Axle Hardware	2
8	DNRB3222-240	Center Roller Axle Hardware	1
9	DNFSE-4	Socket Eye	1
10	DNCP1	Cotter Pin	1
11	DNCB-7A	Aluminum Sheave	1
11	DNCB-7L	Urethane Lined Aluminum Sheave	2
11	DNCB-7DI	Ductile Iron Sheave	1

All sheaves are supplied with bearings installed.

DNSB16U REPAIR PARTS

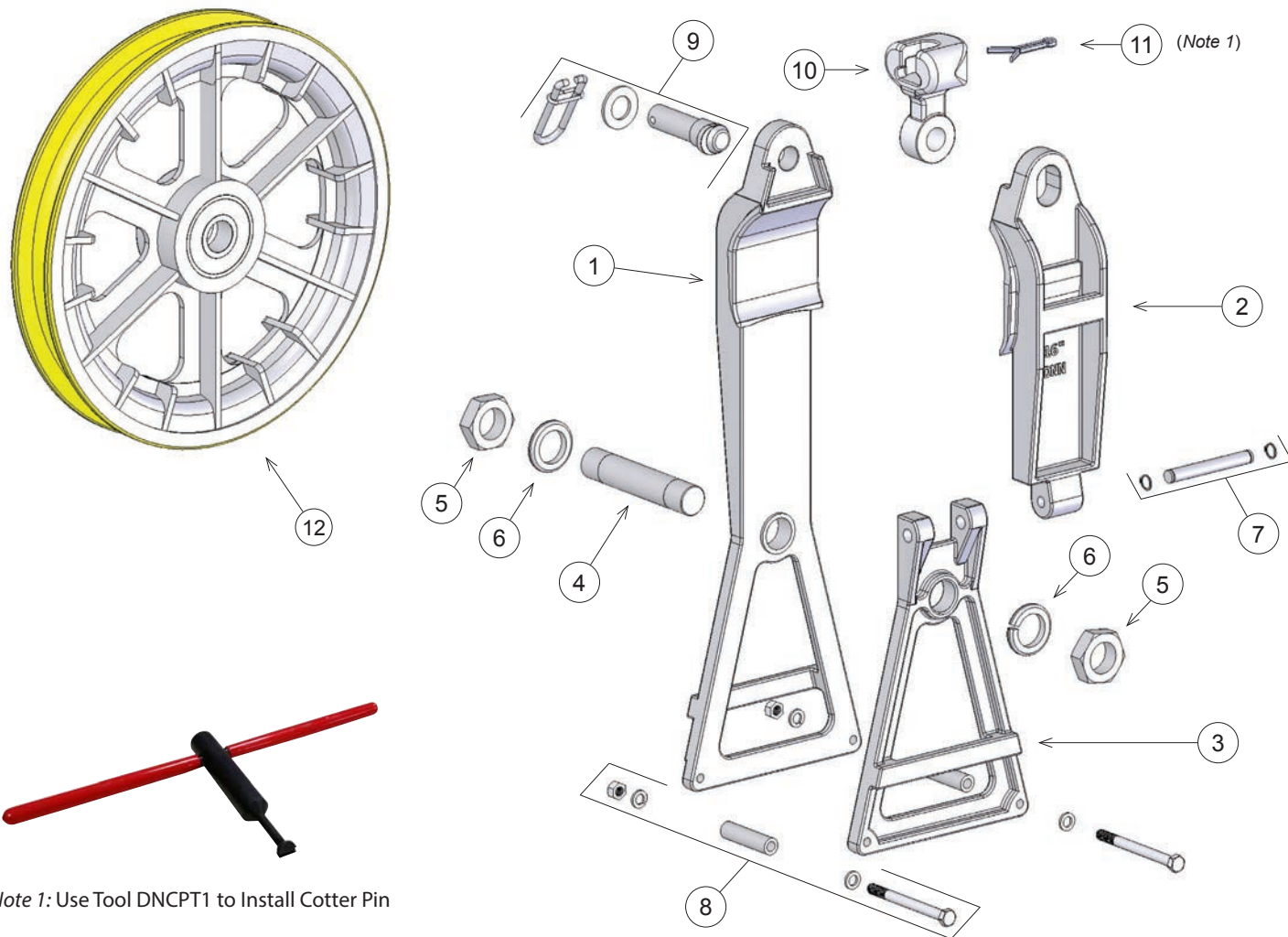

ITEM:	DNSB16U
DESCRIPTION	STRINGING BLOCK, 16" LINED
DATE:	June, 2012

ITEM #	PART #	DESCRIPTION	QTY.
1	DNSB16U-105	Full Frame	1
2	DNSB16U-110	Half Frame, Upper	1
3	DNSB16U-115	Half Frame, Lower	1
4	DNSB16U-120	Axle	1
5	DNSB22U-125	Hex Nut	2
6	DNSB22U-130	Lock Washer	2
7	DNSB16U-135	Connecting Pin & Lock Washers	1
8	DNSB16U-140	Bolt & Spacer Assembly (Set of 2)	1
9	DNSB16U-145	Lock Pin, Pull Ring & Washer	1
10	DNSB22U-150	Socket Eye & Cotter Pin	1
11	DNCP1	Cotter Pin	1
12	DNSB16U-155	Lined Sheave with Bearings	1

DNSB22U REPAIR PARTS

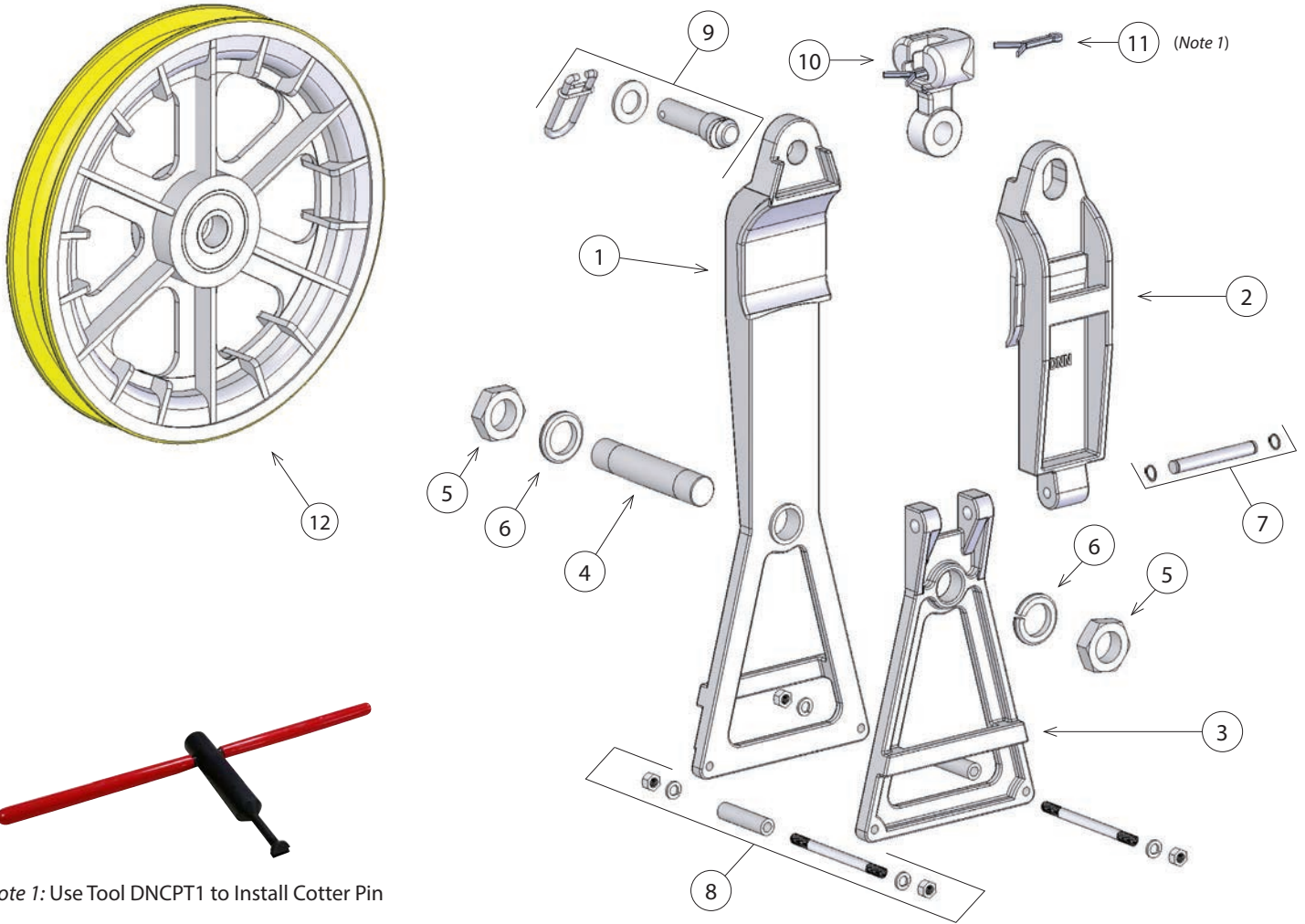

Note 1: Use Tool DNCPT1 to Install Cotter Pin

ITEM:	DNSB22U
DESCRIPTION:	STRINGING BLOCK, 22" LINED
DATE:	June, 2012

ITEM #	PART #	DESCRIPTION	QTY.
1	DNSB22U-105	Full Frame	1
2	DNSB22U-110	Half Frame, Upper	1
3	DNSB22U-115	Half Frame, Lower	1
4	DNSB22U-120	Axle	1
5	DNSB22U-125	Hex Nut	2
6	DNSB22U-130	Lock Washer	2
7	DNSB22U-135	Connecting Pin & Lock Washers	1
8	DNSB22U-140	Bolt & Spacer Assembly (Set of 2)	1
9	DNSB22U-145	Lock Pin, Pull Ring & Washer	1
10	DNSB22U-150	Socket Eye & Cotter Pin	1
11	DNCP1	Cotter Pin	1
12	DNSB22U-155	Lined Sheave with Bearings	1

DNSB28U REPAIR PARTS

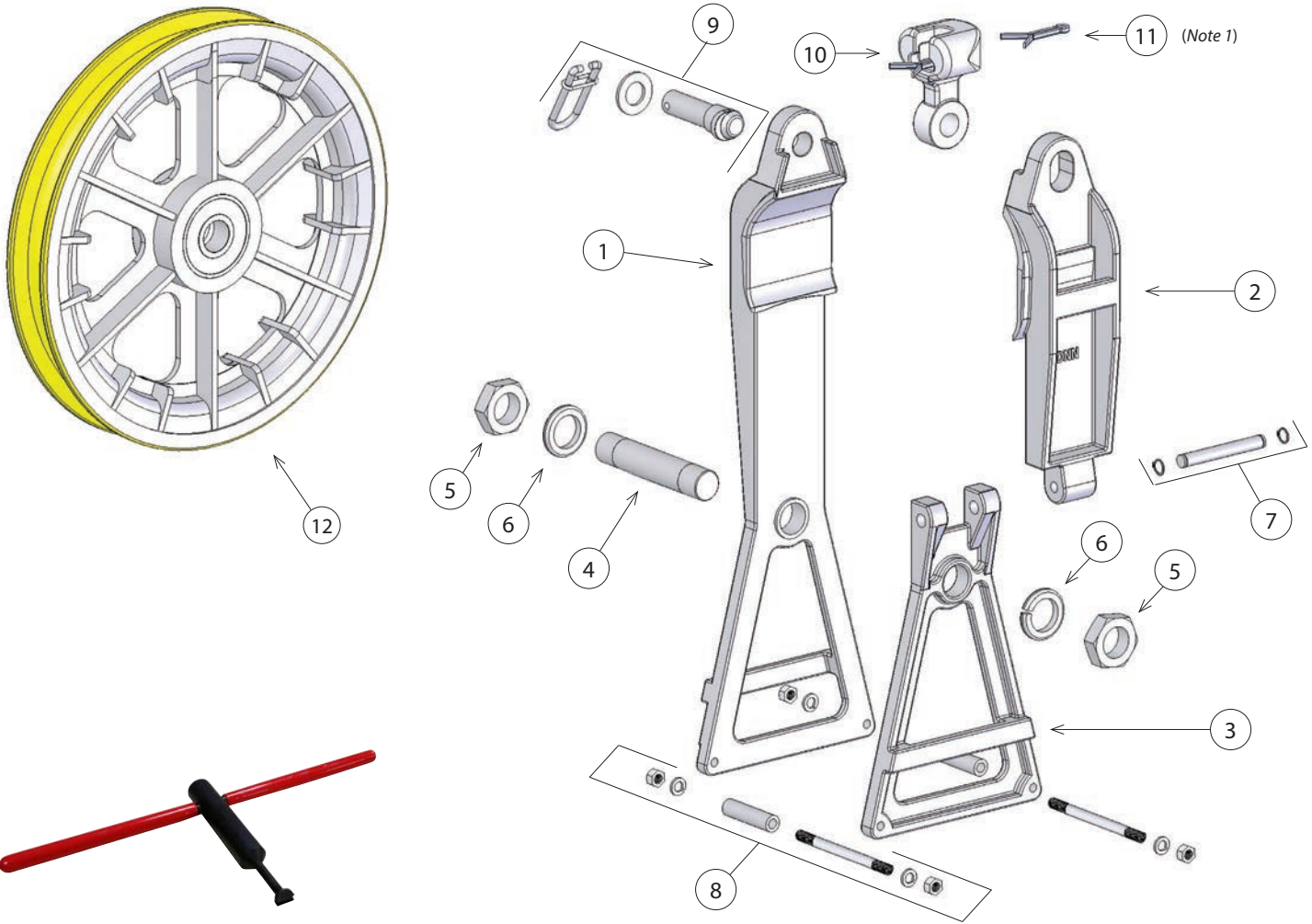

Note 1: Use Tool DNCPT1 to Install Cotter Pin

ITEM:	DNSB28U
DESCRIPTION:	STRINGING BLOCK, 28" LINED
DATE:	June, 2012

ITEM #	PART #	DESCRIPTION	QTY.
1	DNSB28U-105	Full Frame	1
2	DNSB28U-110	Half Frame, Upper	1
3	DNSB28U-115	Half Frame, Lower	1
4	DNSB22U-120	Axle	1
5	DNSB22U-125	Hex Nut	2
6	DNSB22U-130	Lock Washer	2
7	DNSB22U-135	Connecting Pin & Lock Washers	1
8	DNSB22U-140	Bolt & Spacer Assembly (Set of 2)	1
9	DNSB22U-145	Lock Pin, Pull Ring & Washer	1
10	DNSB22U-150	Socket Eye & Cotter Pin	1
11	DNCP1	Cotter Pin	1
12	DNSB28U-155	Lined Sheave with Bearings	1

DNSBW22U REPAIR PARTS

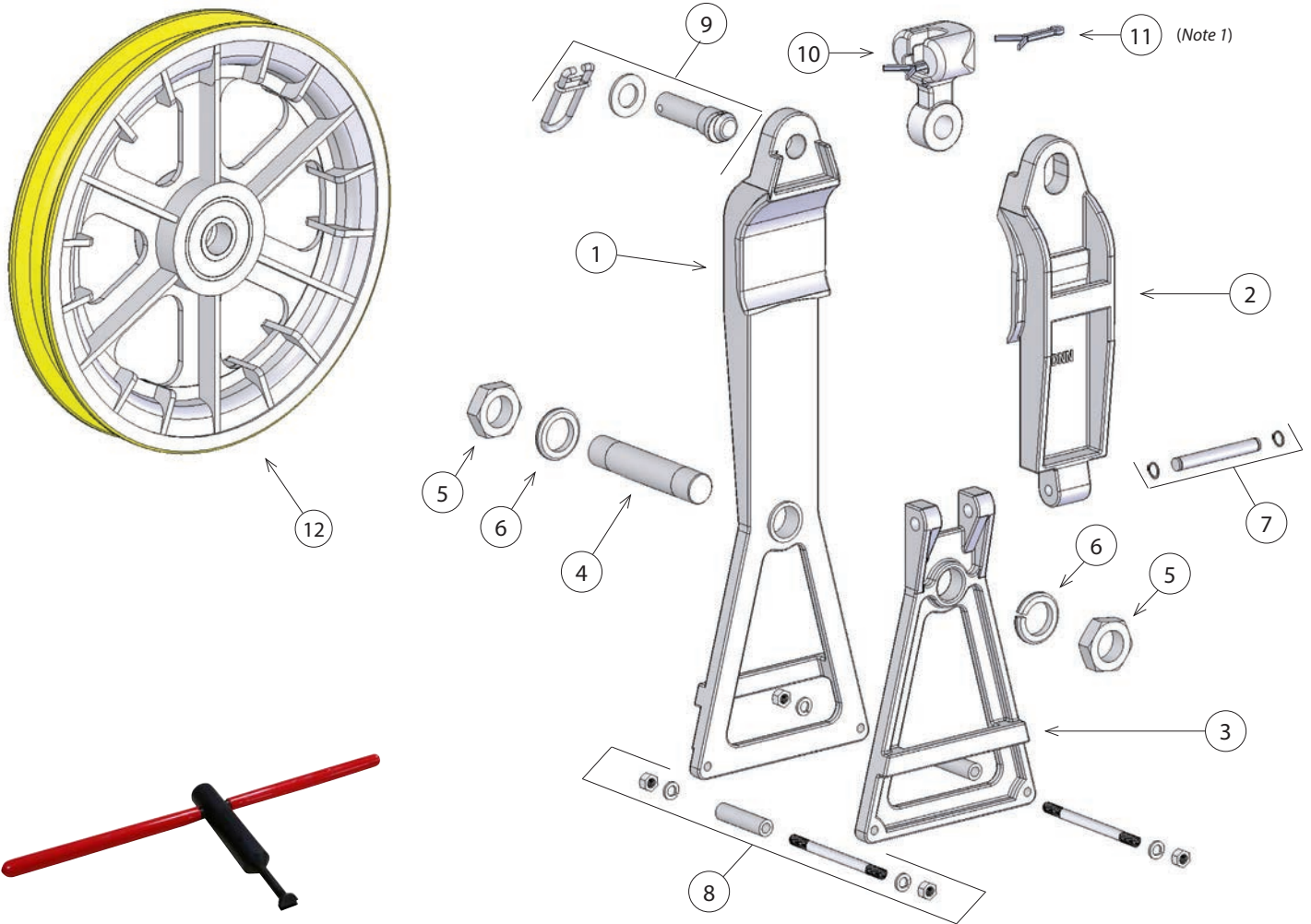

Note 1: Use Tool DNCPT1 to Install Cotter Pin

ITEM:	DNSBW22U
DESCRIPTION:	STRINGING BLOCK, WIDE THROAT, 22"
DATE:	June, 2012

ITEM #	PART #	DESCRIPTION	QTY.
1	DNSBW22U-105	Full Frame	1
2	DNSBW22U-110	Half Frame, Upper	1
3	DNSB22U-115	Half Frame, Lower	1
4	TESBW22U-120	Axle	1
5	DNSB22U-125	Hex Nut	2
6	DNSB22U-130	Lock Washer	2
7	DNSB22U-135	Connecting Pin & Lock Washers	1
8	DNSBW22U-140	Bolt, Washers, Nut & Spacer	2
9	DNSB22U-145	Lock Pin, Pull Ring & Washer	1
10	DNSB22U-150	Socket Eye & Cotter Pin	1
11	DNCP1	Cotter Pin	1
12	DNSBW22U-155	Lined Sheave with Bearings	1

DNSBW28U REPAIR PARTS

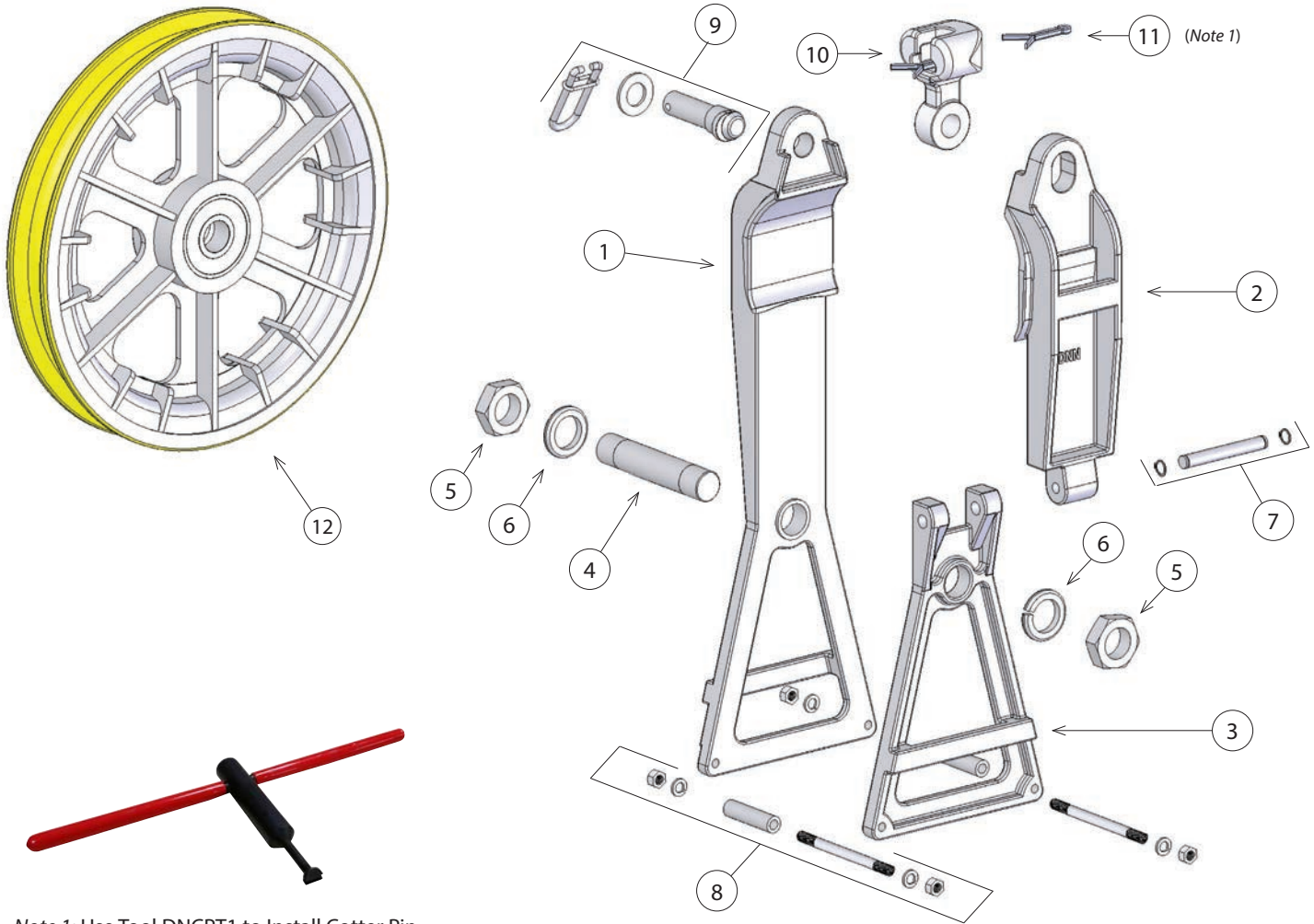

Note 1: Use Tool DNCPT1 to Install Cotter Pin

ITEM:	DNSBW28U
DESCRIPTION:	STRINGING BLOCK, WIDE THROAT, 28"
DATE:	June, 2012

ITEM #	PART #	DESCRIPTION	QTY.
1	DNSBW28U-105	Full Frame	1
2	DNSBW28U-110	Half Frame, Upper	1
3	DNSB28U-115	Half Frame, Lower	1
4	DNSBW22U-120	Axle	1
5	DNSB22U-125	Hex Nut	2
6	DNSB22U-130	Lock Washer	2
7	DNSB22U-135	Connecting Pin & Lock Washers	1
8	DNSBW22U-140	Bolt & Spacer Assembly (Set of 2)	1
9	DNSB22U-145	Lock Pin, Pull Ring & Washer	1
10	DNSB22U-150	Socket Eye & Cotter Pin	1
11	DNCPT1	Cotter Pin	1
12	DNSBW28U-155	Lined Sheave with Bearings	1

DNSBW42U REPAIR PARTS

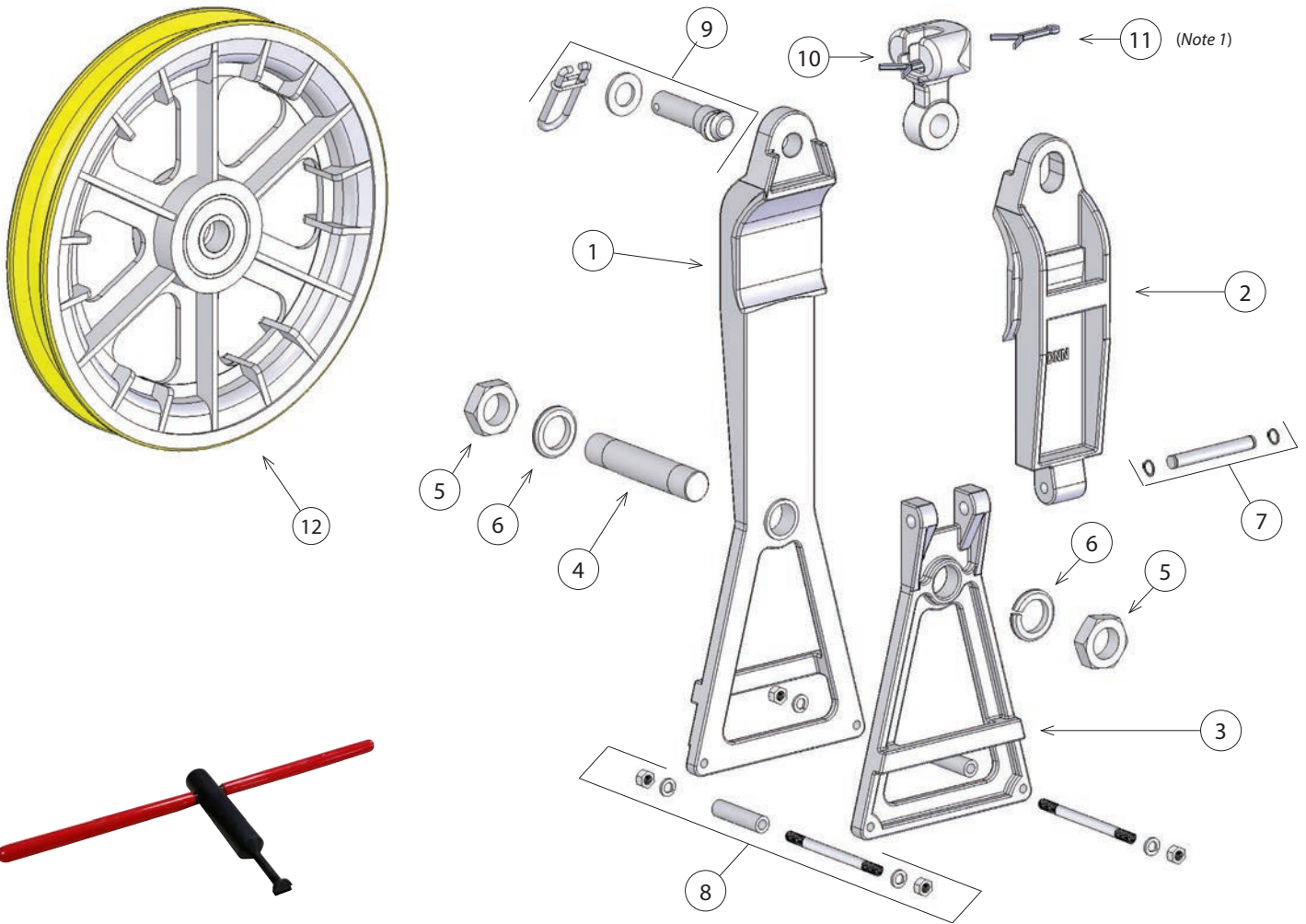

Note 1: Use Tool DNCPT1 to Install Cotter Pin

ITEM:	DNSBW42U
DESCRIPTION	STRINGING BLOCK, WIDE THROAT, 42"
DATE:	June, 2012

ITEM #	PART #	DESCRIPTION	QTY.
1	DNSBW42U-105	Full Frame	1
2	DNSBW42U-110	Half Frame, Upper	1
3	DNSBW42U-115	Half Frame, Lower	1
4	DNSBW42U-120	Axle	1
5	DNSBW42U-125	Hex Nut	2
6	DNSBW42U-130	Lock Washer	2
7	DNSBW42U-135	Connecting Pin & Lock Washers	1
8	DNSBW42U-140	Bolt & Spacer Assembly (Set of 2)	1
9	DNSBW42U-145	Lock Pin, Pull Ring & Washer	1
10	DNSB22U-150	Socket Eye & Cotter Pin	1
11	DNCP1	Cotter Pin	1
12	DNSBW42U-155	Lined Sheave with Bearings	1

DNTG75-2HD REPAIR PARTS

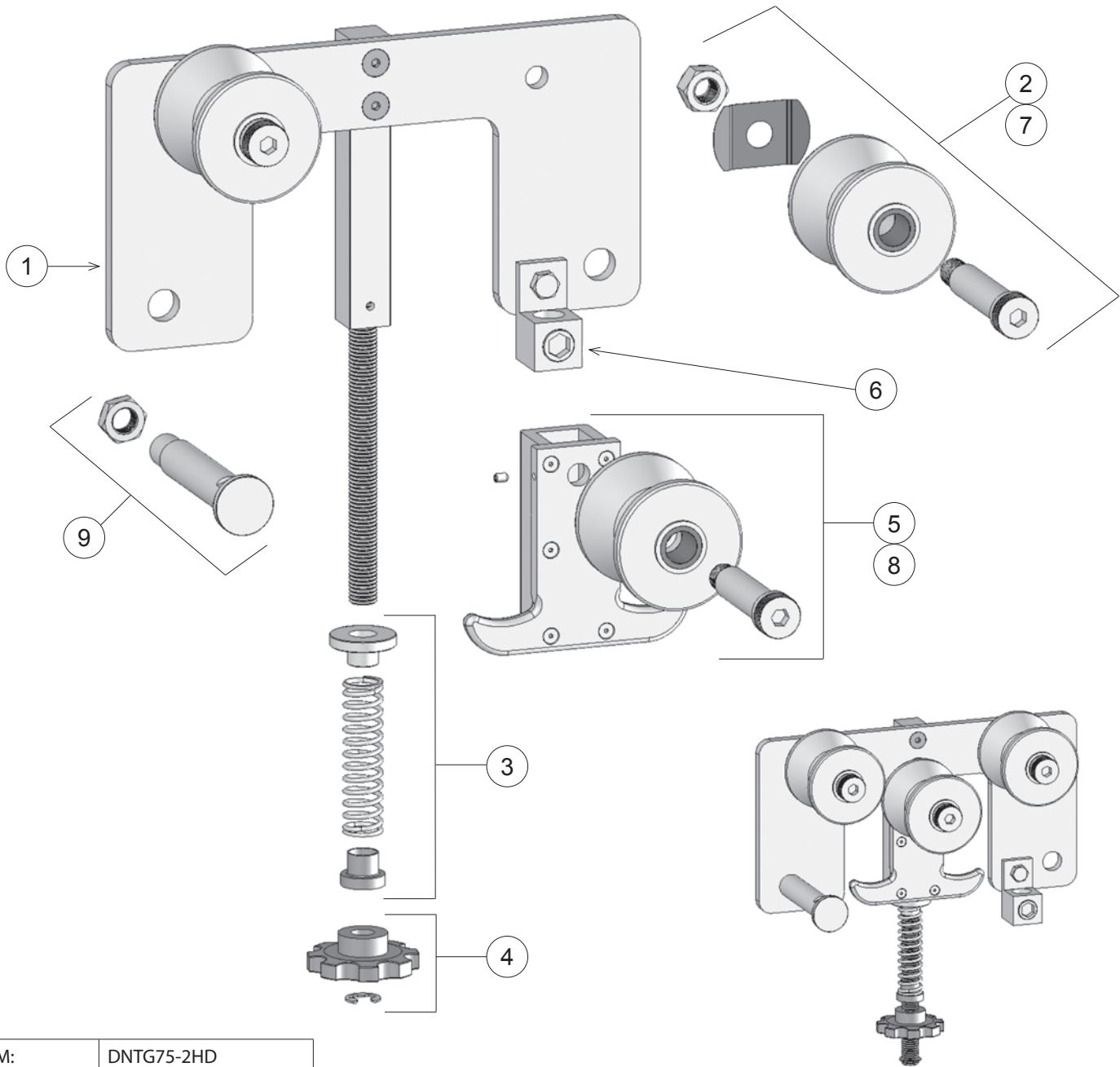

ITEM:	DNTG75-2HD
DESCRIPTION:	TRAVELING GROUND
DATE:	April, 2011

ITEM #	PART #	DESCRIPTION	QTY.
1	DNTG75-705	Main Frame & Threaded Bolt Assembly	1
2	DNTG75-710	Upper Roller Assembly, Aluminum	2
3	DNTG75-715	Handle Spring Assembly	1
4	DNTG75-720	Hand Knob with E-Ring	1
5	DNTG75-725	Center Pull Handle Assembly, Aluminum	1
6	DNTG75-730	Ground Lug with Bolt & Nut (Penetrox Required)	1
7	DNTG75-735	Upper Roller Assembly, Steel	2
8	DNTG75-740	Center Pull Handle Assembly, Steel	1
9	DNTG75-745	Reversible Ground Stud & Nut	1

DNTG250-1625 REPAIR PARTS (NEW STYLE)

NEW STYLE - AFTER MAY 1, 2011

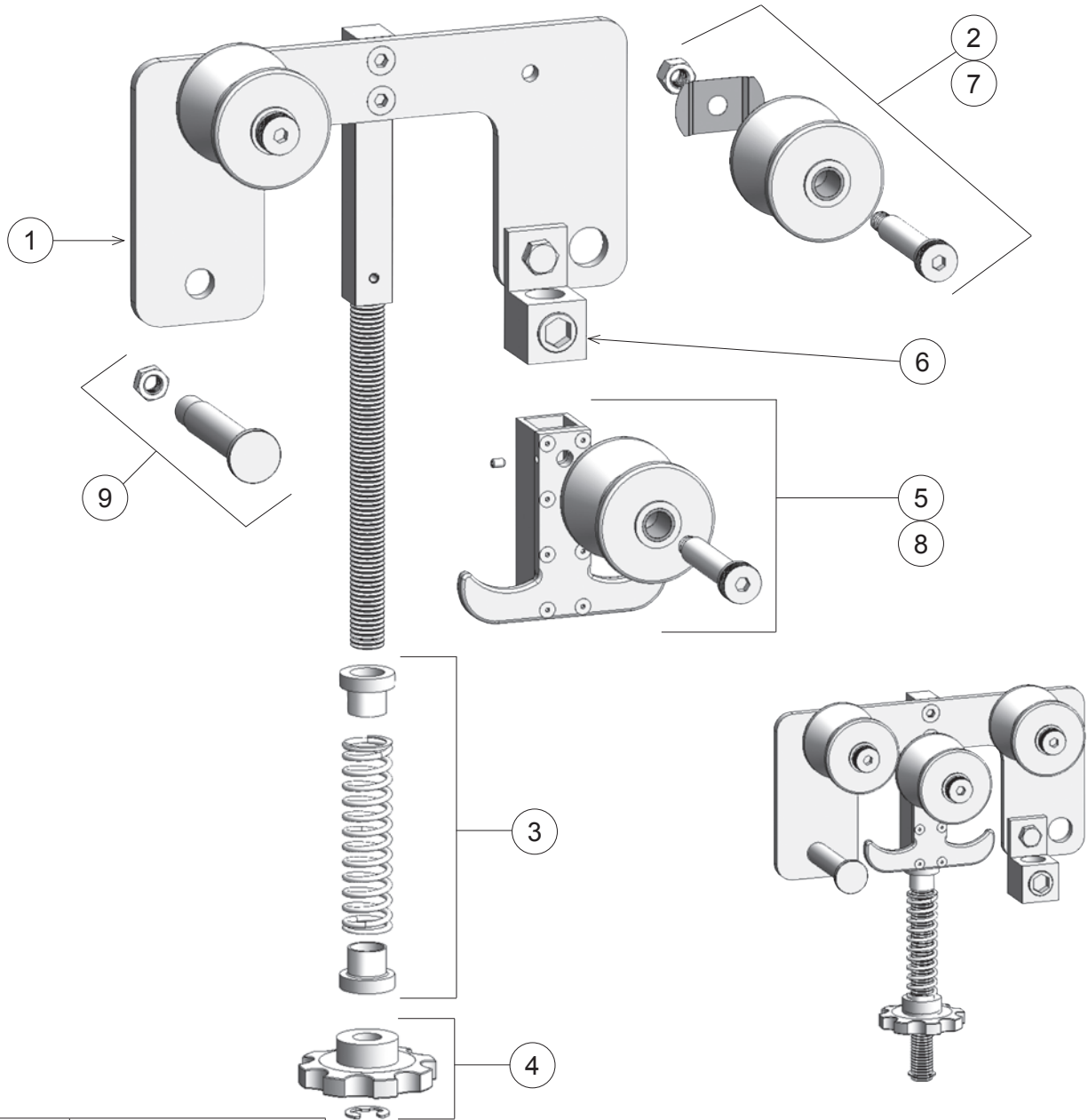

ITEM:	DNTG250-1625
DESCRIPTION:	TRAVELING GROUND
DATE:	May, 2011

ITEM #	PART #	DESCRIPTION	QTY.
1	DNTG250-205	Main Frame & Threaded Bolt Assembly	1
2	DNTG250-210	Upper Roller Assembly, Aluminum	2
3	DNTG250-215	Handle Spring Assembly	1
4	DNTG250-220	Hand Knob with E-Ring	1
5	DNTG250-225	Center Pull Handle Assembly, Aluminum	1
6	DNTG250-230	Ground Lug with Bolt & Nut (Penetrox Required)	1
7	DNTG250-235	Upper Roller Assembly, Steel	2
8	DNTG250-240	Center Pull Handle Assembly, Steel	1
9	DNTG250-245	Reversible Ground Stud & Nut	1

DNTG250-1625 REPAIR PARTS (OLD STYLE)

OLD STYLE - PRIOR TO APRIL 30, 2011

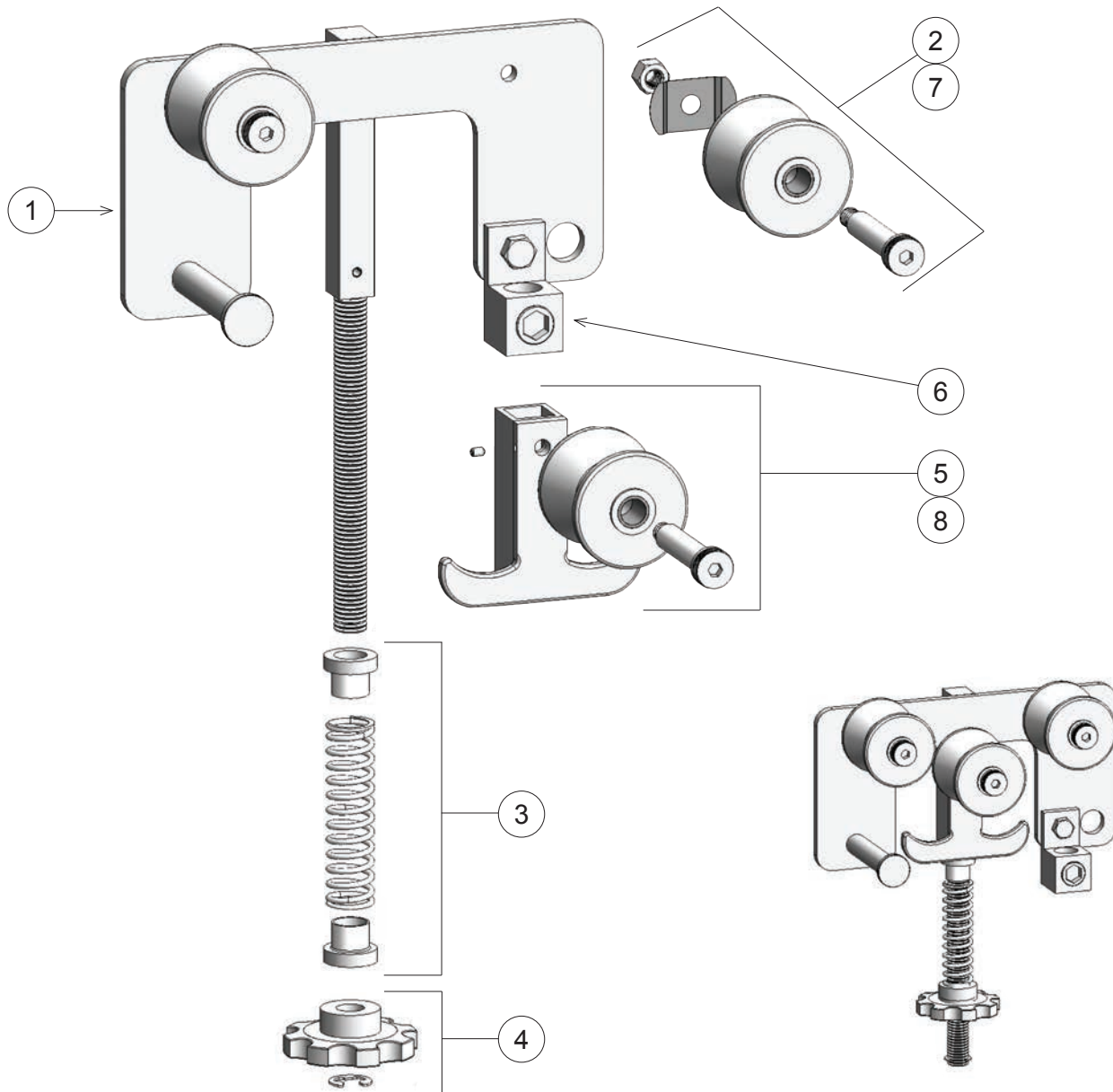

ITEM:	DNTG250-1625
DESCRIPTION:	TRAVELING GROUND
DATE:	Prior to April 30, 2011

ITEM #	PART #	DESCRIPTION	QTY.
1	DNTG250-205	Main Frame & Threaded Bolt Assembly	1
2	DNTG250-210	Upper Roller Assembly, Aluminum	2
3	DNTG250-215	Handle Spring Assembly	1
4	DNTG250-220	Hand Knob with E-Ring	1
5	DNTG250-225	Center Pull Handle Assembly, Aluminum	1
6	DNTG250-230	Ground Lug with Bolt & Nut (Penetrox Required)	1
7	DNTG250-235	Upper Roller Assembly, Steel	2
8	DNTG250-240	Center Pull Handle Assembly, Steel	1

DNBG12 REPAIR PARTS

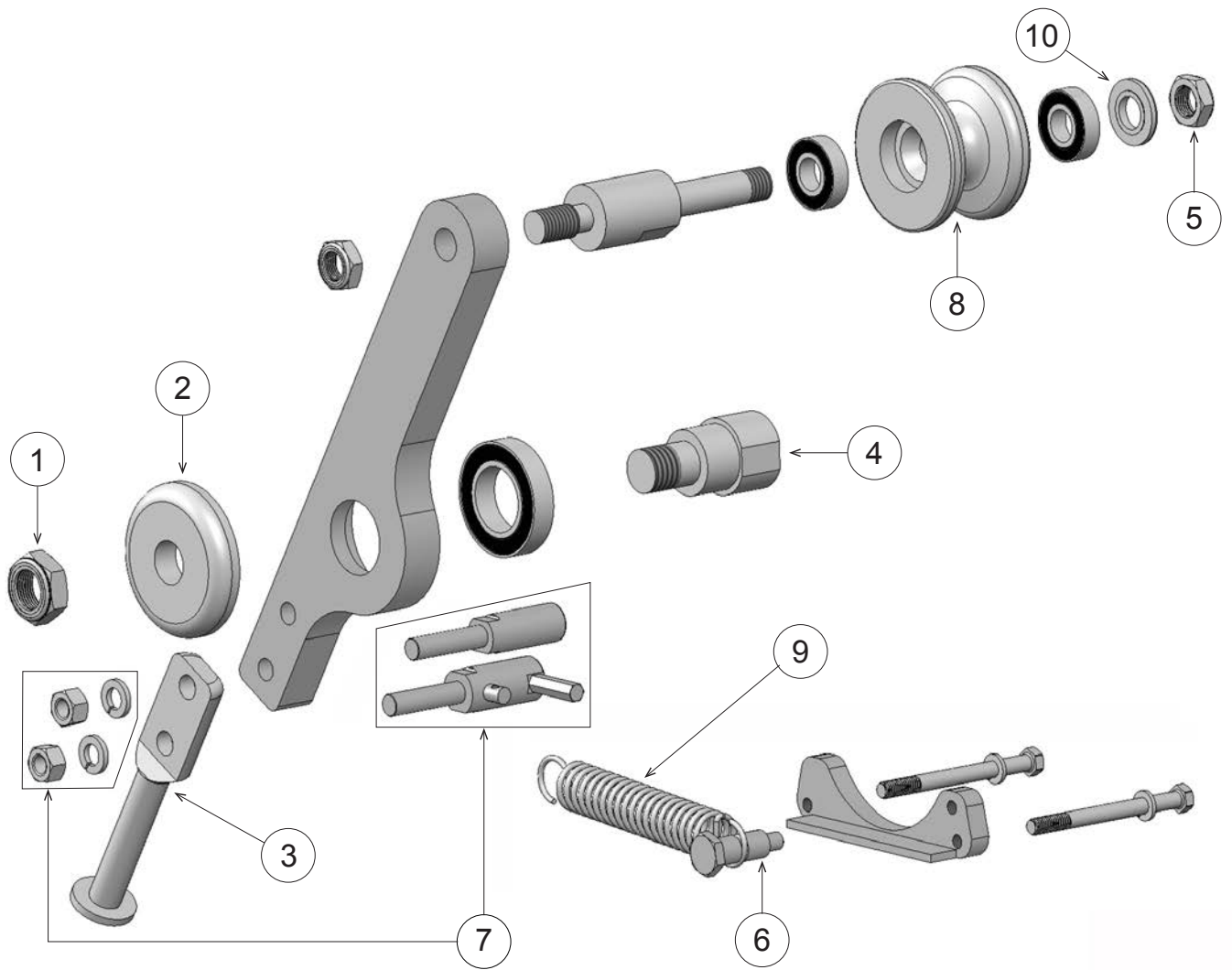

ITEM #	PART #	DESCRIPTION	QTY
1	DNBG-10014	BG Main Axle Nut	1
2	DNBG-1037	Bearing Guard - DNBGV42, DNBGV36	1
3	DNBG-1480	BG Ground Stud - DNBGV42, DNBGV36	1
4	DNBG-2065	Axle Adapter - DNBG16, DNBG12	1
5	DNBG-75016	Upper Axle Nut	1
6	DNBG12-3020	BG Lower Spring Mount - DNBG12	1
7	DNBG12-3080	BG Spring Mount KIT - DNBG12	1
8	DNBG16-2045	BG Roller, Aluminum, for DNBG12, DNBG16	1
9	DNFV0032050	BG Spring Only - DNBG16, DNBG12	1
10	DNTG75-810	Bearing Guard - DNBG22-28, DNBG16, DNBG12	1

DNBG16 REPAIR PARTS

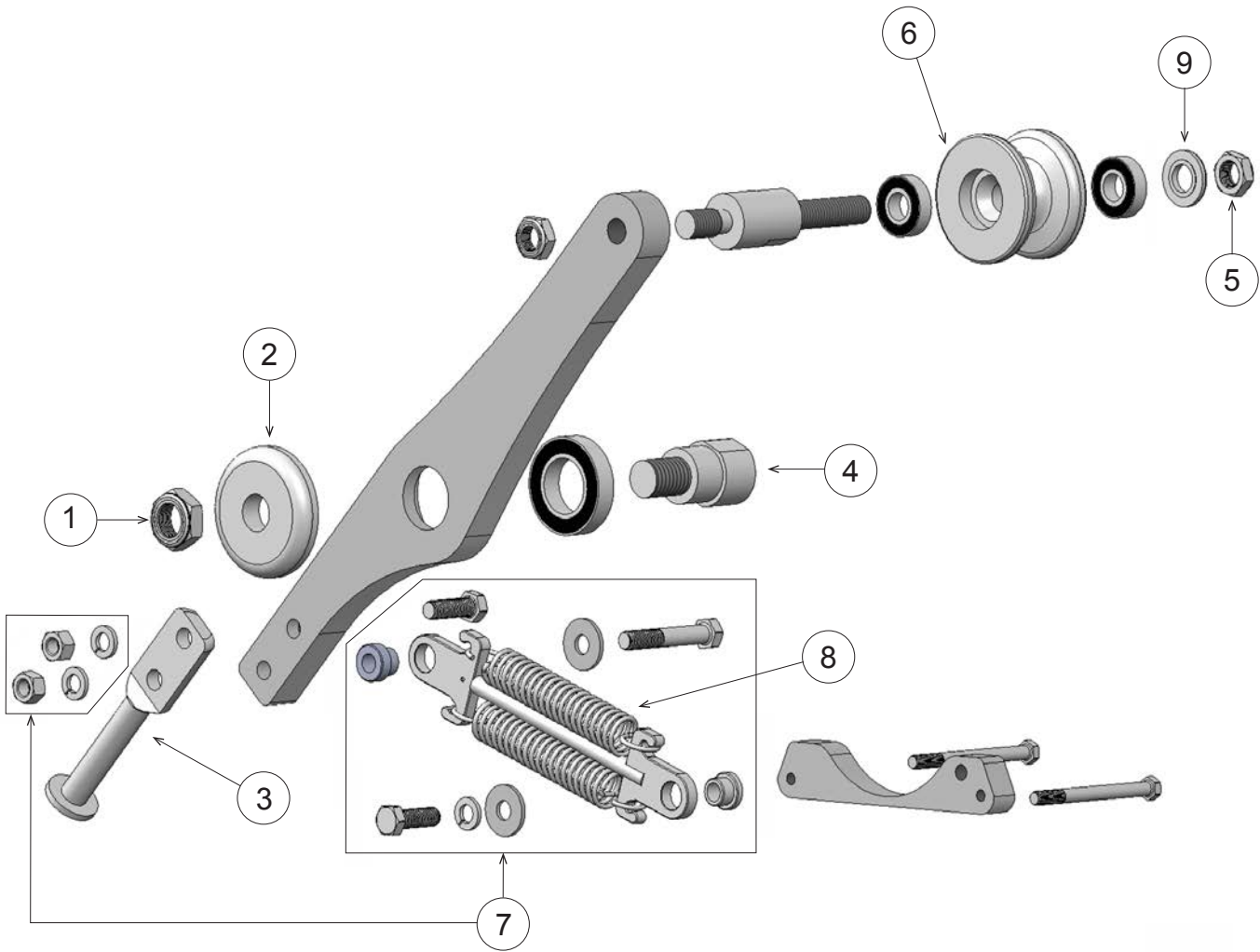

ITEM #	PART #	DESCRIPTION	QTY
1	DNBG-10014	BG Main Axle Nut	1
2	DNBG-1037	Bearing Guard - DNBGV42, DNBGV36	1
3	DNBG-1480	BG Ground Stud - DNBGV42, DNBGV36	1
4	DNBG-2065	Axle Adapter - DNBG16, DNBG12	1
5	DNBG-75016	Upper Axle Nut	1
6	DNBG16-2045	BG Roller, Aluminum, for DNBG12, DNBG16	1
7	DNBG16-2095	BG Spring KIT forDNBG16	1
8	DNFV0032050	BG Spring Only - DNBG16, DNBG12	2
9	DNTG75-810	Bearing Guard - DNBG22-28, DNBG16, DNBG12	1

DNBG22-28 REPAIR PARTS

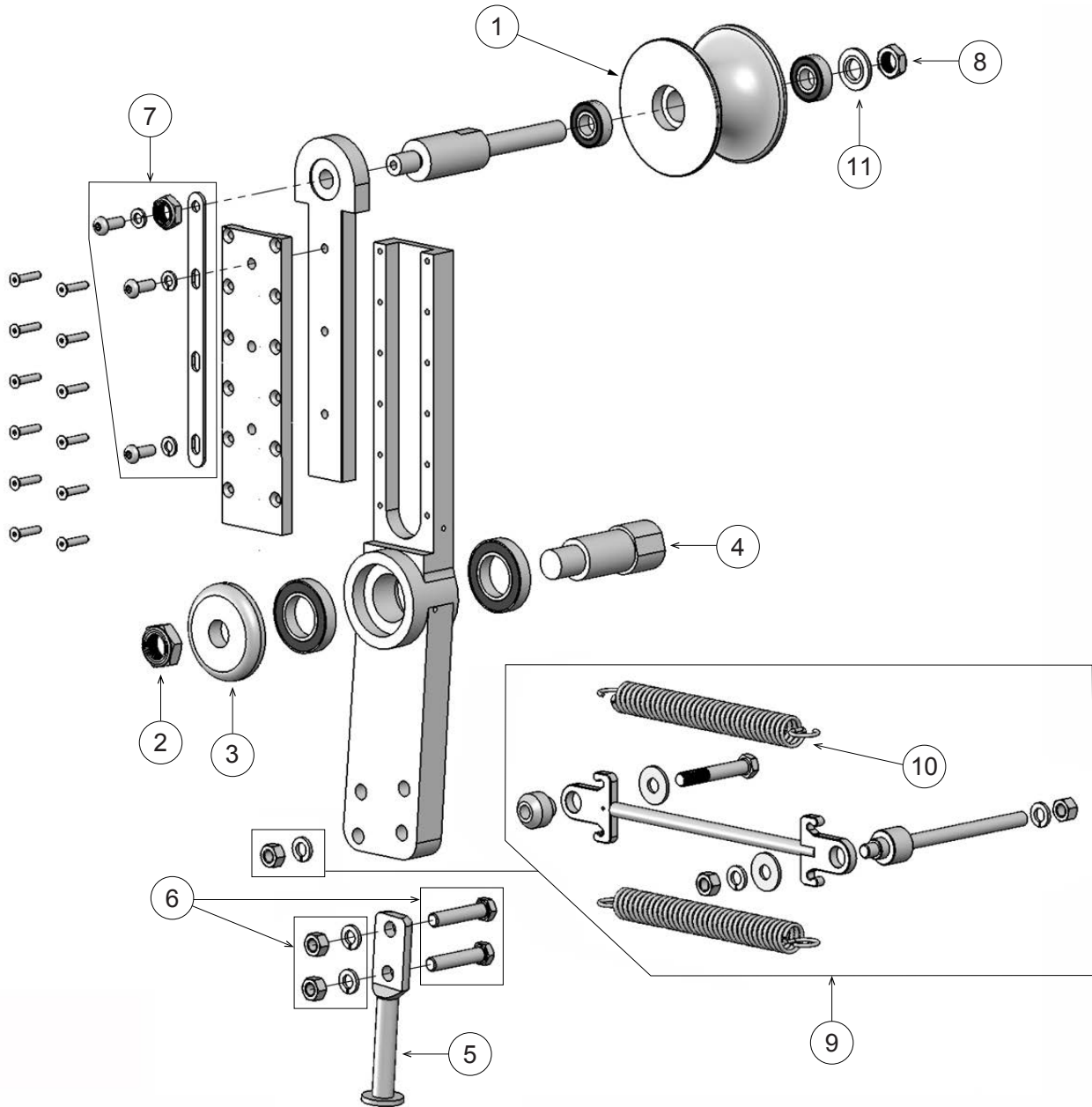

ITEM #	PART #	DESCRIPTION	QTY
1	DN5AL	5 Inch Aluminum Roller	1
2	DNBG-10014	BG Main Axle Nut	1
3	DNBG-1037	Bearing Guard - DNBGV42, DNBGV36	1
4	DNBG-1069	Axle Adapter - DNBG22-28, DNBGV22-28	1
5	DNBG-1480	BG Ground Stud - DNBGV42, DNBGV36	1
6	DNBG-2080	Bolt Kit for: DNBGV42, DNBGV36, DNBGV22-28, DNBG22-28	1
7	DNBG-2090	Ground Bar with Hardware for: DNBGV22-28, DNBG22-28	1
8	DNBG-70516	Upper Axle Nut	1
9	DNBG2228	BG Spring KIT for DNBGV22-28	1
10	DNFV0024721	BG Spring Only - DNBGV22-28, DNBG22-28	1
11	DNTG75-810	Bearing Guard - DNBG22-28, DNBG16, DNBG12	1

DNBGV22-28 REPAIR PARTS

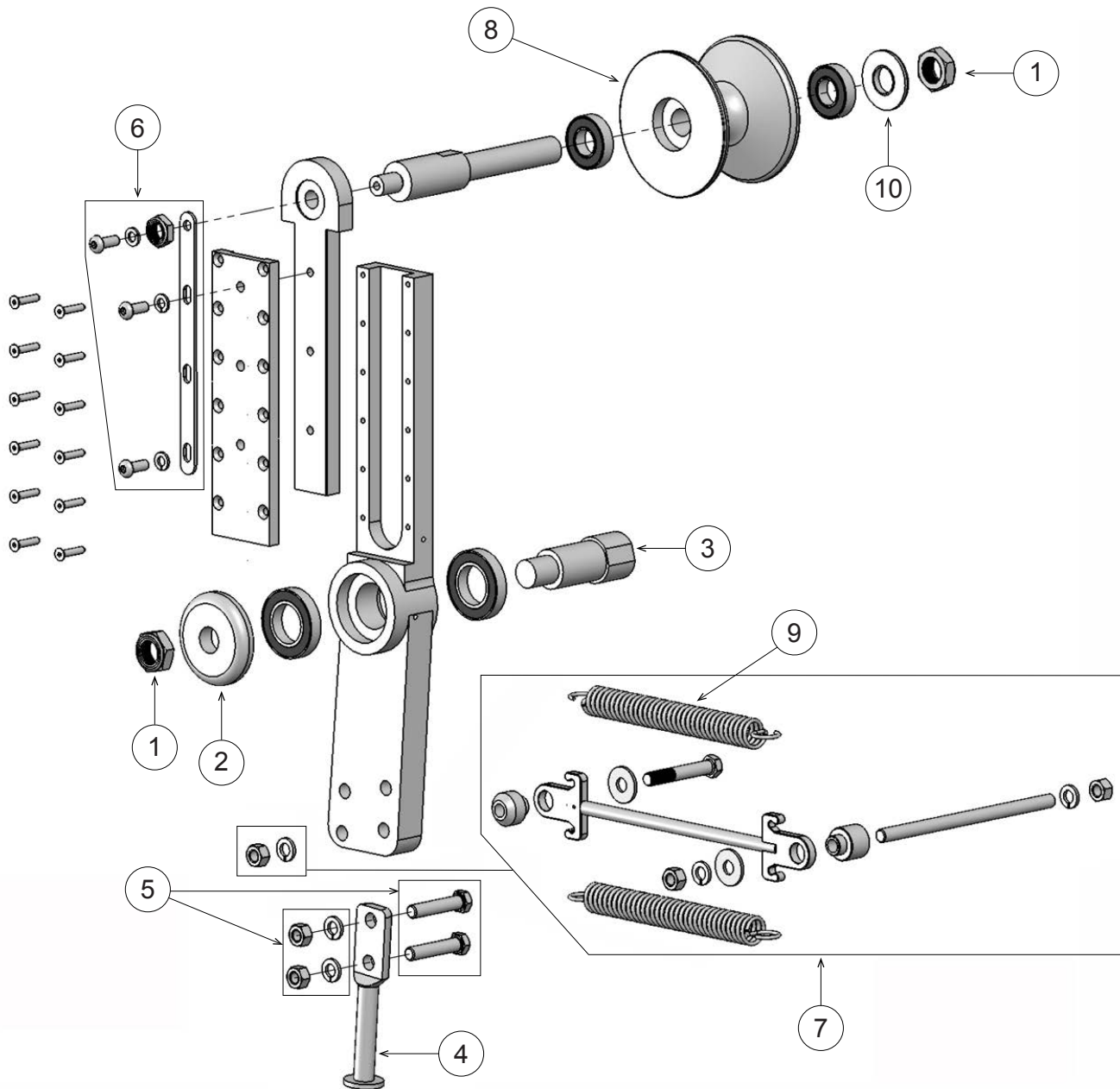

ITEM #	PART #	DESCRIPTION	QTY
1	DNBG-10014	BG Main Axle Nut	2
2	DNBG-1037	Bearing Guard - DNBGV42, DNBGV36	1
3	DNBG-1069	Axle Adapter - DNBG22-28, DNBGV22-28	1
4	DNBG-1480	BG Ground Stud - DNBGV42, DNBGV36	1
5	DNBG-2080	Bolt Kit for: DNBGV42, DNBGV36, DNBGV22-28, DNBG22-28	1
6	DNBG-2090	Ground Bar with Hardware for: DNBGV22-28, DNBG22-28	1
7	DNBGV2228	BG Spring Kit for DNBGV22-28	1
8	DNBGV5A	BG Roller, Aluminum, for DNBG22-28	1
9	DNFV0024721	BG Spring Only - DNBGV22-28, DNBG22-28	1
10	DNTG80-1650	Bearing Guard - DNBGV22-28	1

DNBGV36 REPAIR PARTS

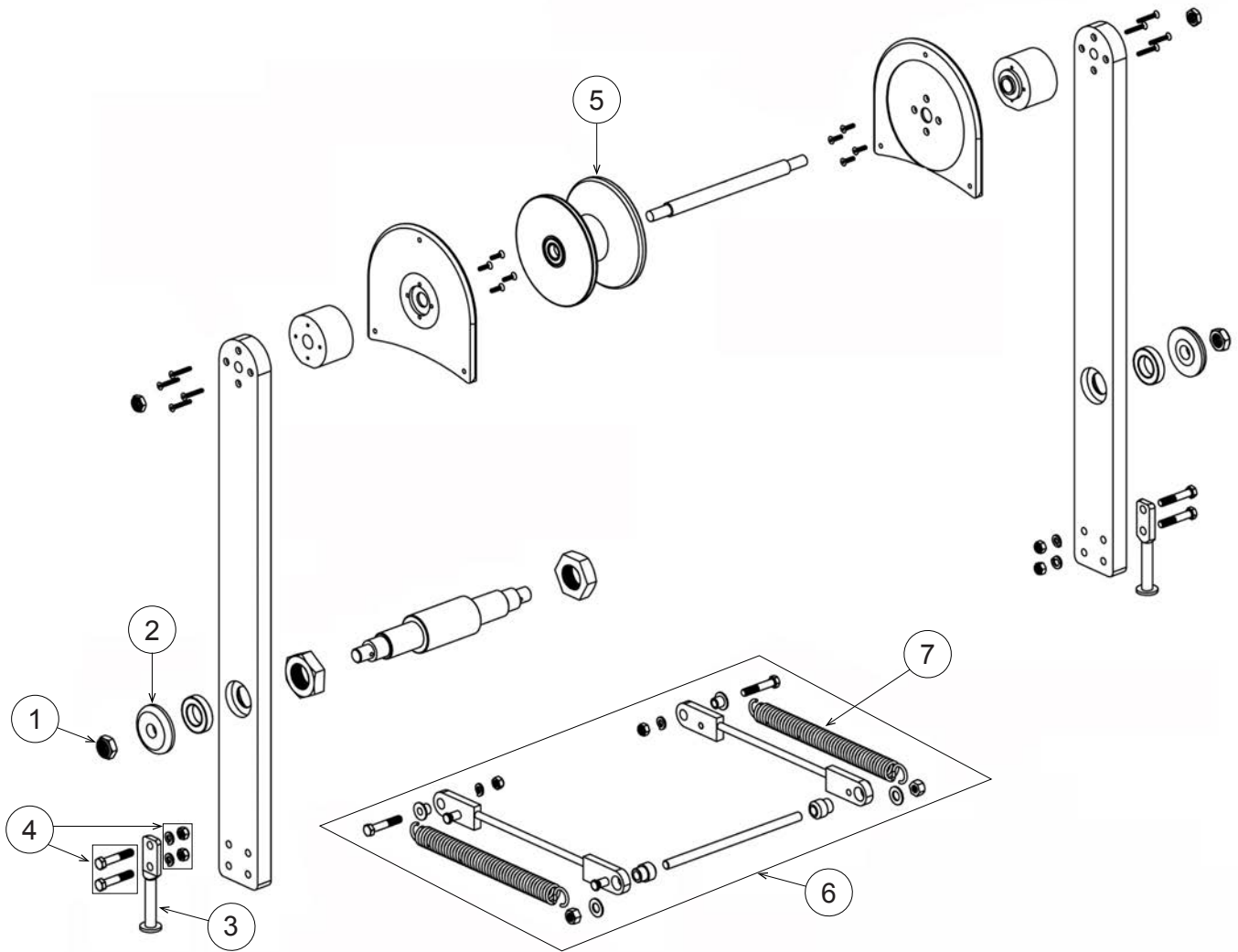

ITEM #	PART #	DESCRIPTION	QTY
1	DNBG-10014	BG Main Axle Nut	1
2	DNBG-1037	Bearing Keeper - DNBGV42, DNBGV36	1
3	DNBG-1480	BG Ground Stud - DNBGV42, DNBGV36	1
4	DNBG-2080	Bolt Kit for: DNBGV42, DNBGV36, DNBGV22-28, DNBG22-28	1
5	DNBGV36-1095	BG Roller, Aluminum, for DNBGV36	1
6	DNBGV36-42	36" & 42" Spring Kit	1
7	DNFV0032734	BG Spring Only - DNBGV42, DNBGV36	1

DNBGV42 REPAIR PARTS

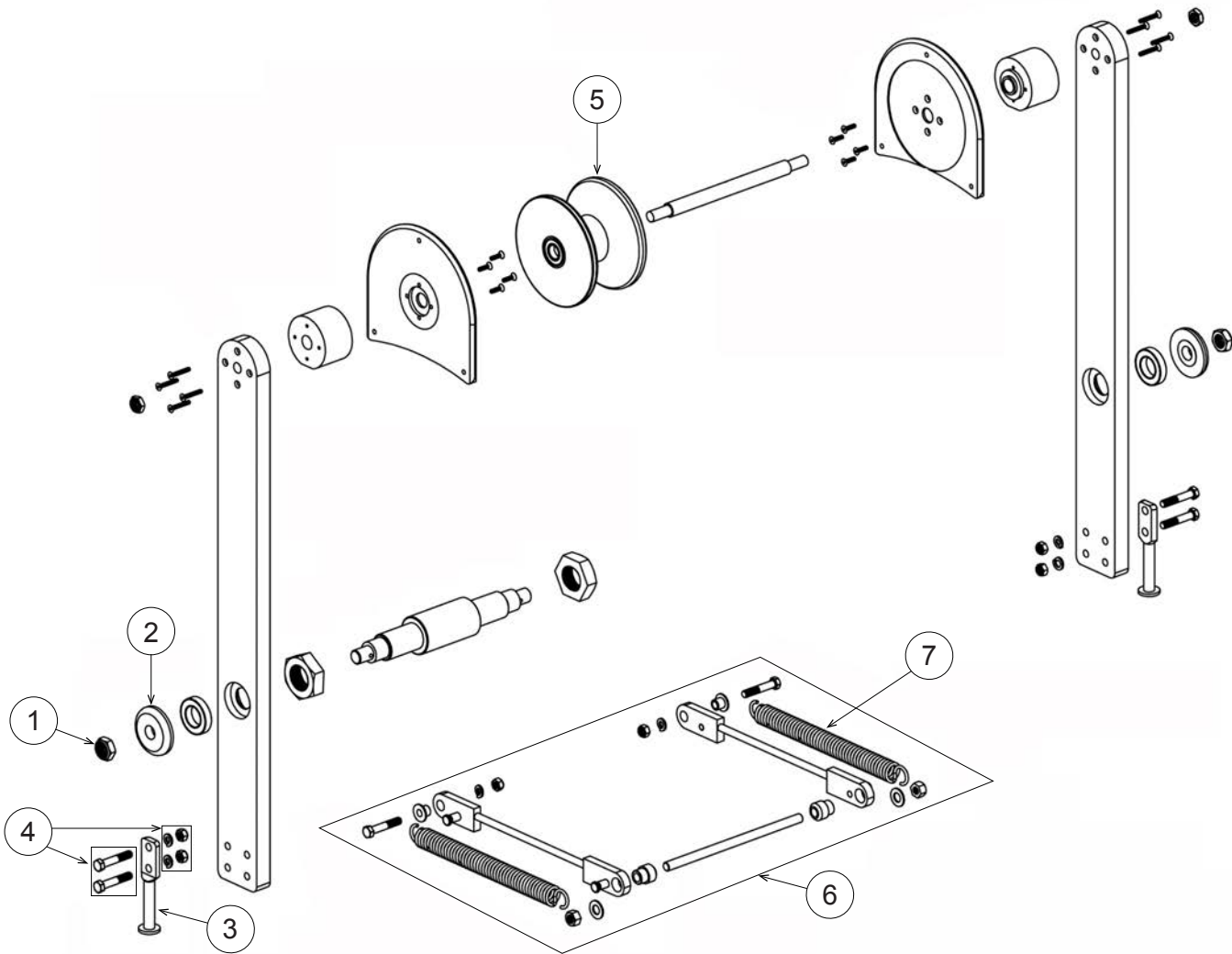

ITEM #	PART #	DESCRIPTION	QTY
1	DNBG-10014	BG Main Axle Nut	1
2	DNBG-1037	Bearing Keeper - DNBGV42, DNBGV36	1
3	DNBG-1480	BG Ground Stud - DNBGV42, DNBGV36	1
4	DNBG-2080	Bolt Kit for: DNBGV42, DNBGV36, DNBGV22-28, DNBG22-28	1
5	DNBG80-1095	BG Roller, Aluminum, for DNBGV42	1
6	DNBGV36-42	36" & 42" Spring Kit	1
7	DNFV0032734	BG Spring Only - DNBGV42, DNBGV36	1

ST500 & ST800 APPLICATION NOTES

PROCEDURE FOR TESTING SERVICE CONNECTIONS

Pull meter base. Attach alligator clips to either hot leg / neutral and turn power switch on and observe voltage / current reading. After one minute, the ST500 or ST800 will give a red or green pass/fail light in conjunction with the maximum voltage and ampacity of the circuit. With only 3 possible connections the operator can quickly identify a potential problem.

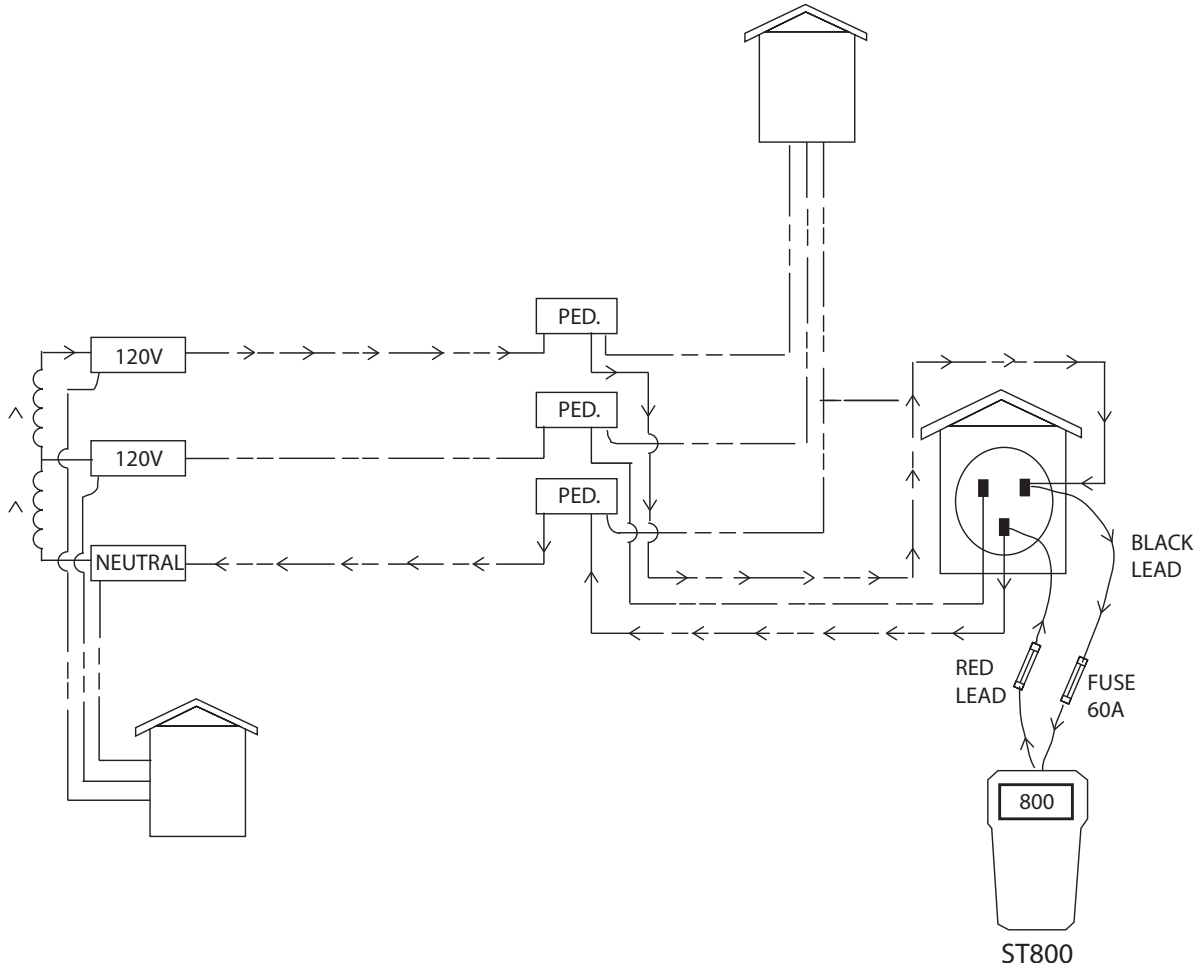

PROCEDURE FOR TESTING DE-ENERGIZED URD PRIMARY CABLE FOR DEAD

Isolate the URD Cable on near end and leave grounded on far end. Test for dead using approved voltage detection device. Install ST500 or ST800 between hot leg of secondary and center conductor of URD grounded cable. Using the meter probe at the open point, identify the dead cable via audible/visual tone.

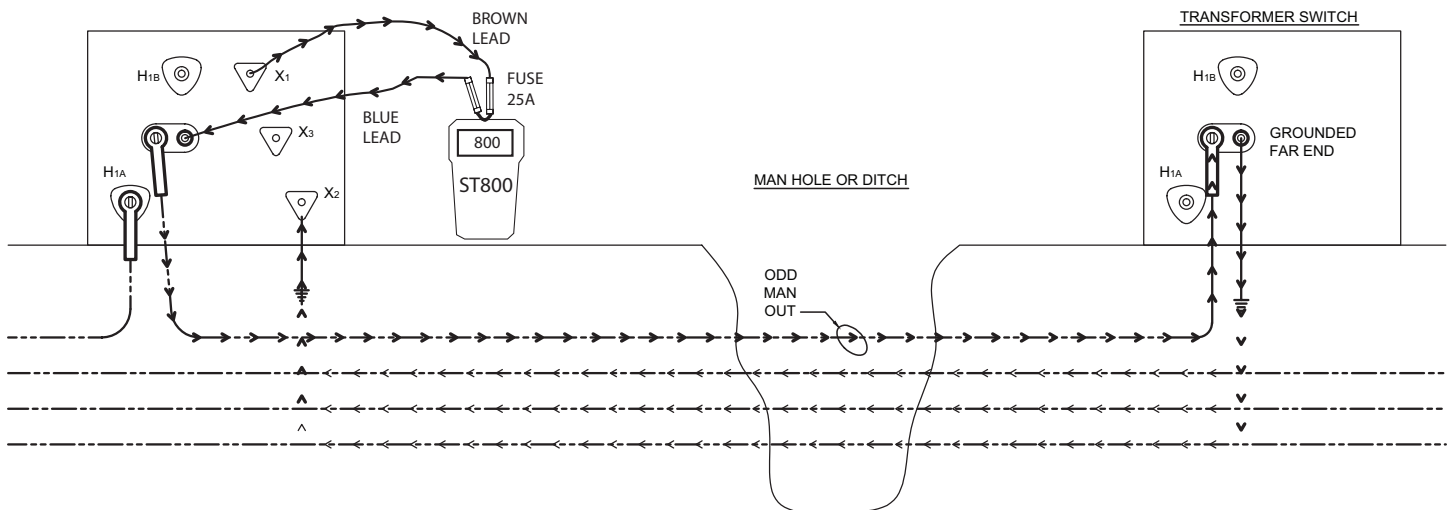

INDEX

A

ACSR Cutter	29, 271, 275
Adjustable Wrenches	1
Aerial Bucket Hooks	94
Aerial Bucket Tool Apron	93
Aerial Bucket Tool Holder	95–96
Aerial Tool Bucket	92
After Fall Rescue Ladder	98
All Angle Stringing Block	229
Aluminum Split Bells	382
Aluminum Test Mandrels	378
Aluminum Test Slugs	378
Ammeter	345
Ampact Bag	86
Ampstick	345
Anchor Installing Tools	352–354
Anchor Tool	354
Anchor Tool Accessories	354
Anti-Fatigue Floor Mats	97
Arborist Gear	74–82
ARC Resistant Rain Gear	128–129
ARC Snuffer Tools	328
ARC Suppression Blankets	142
Armor Rod Bag	90
Armor Rod Tool	334
Augers	355
Auger Teeth	355
AV Meter	338

B

Baker Board	329
Ball Clevis	230
Ball Stud Grounding Clamps	248
Ball Studs	248
Banana Peeler	369
Barricades	146
Bashlin Tool Belt Accessories	108
Bashlin Tool Belts	106–107
Bashlin Tool Belt Sizing Chart	105

Battery Powered Hammer Drills	48–54
Battery Powered Hydraulic Pump	311
Battery Powered Impact Wrenches	34–39
Battery Powered Saws	82
Beast Meters	339
Bell Wrenches	1
Belt Accessories	108, 113
Big Buck Climber Pad	68, 122
Blanket Canister	136
Blowers	368
Body Belt Sizing Chart	109
Bolt Circle Adapter	352
Bolt Cutters	25, 267
Bolt-Thru Wrench	9–10, 336
Boom Strap	98
Box Wrenches	7–9
Breakaway Bonding Sleeve	252
Break-Away Swivels	214
Breaker Attachments	59
Broken Lamp Base Remover	335
Brush Blade	21
Bucket Covers	97
Bucket Hooks	94
Buckingham Body Belt Accessories	113
Buckingham Body Belts	110–112
Buckingham Body Belt Sizing Chart	109
BuckIt Restraint System	98
Bug Wrenches	7
Bulldog Grips	202

C

Cable Cutters	25, 27–29, 68–277
Cable Feeding Sheaves	381
Cable Guides	382
Cable Jacket Slitter	385
Cable Length Meter	337
Cable Locators	349–351
Cable Reel Ground Sets	164, 238, 255
Cable Splicers Kit	23

INDEX

Cable Stripper	369–370	Conductor Stringing System	224–225
Cant Hooks	360–361	Cones	146
Canvas Gear Bags	88–89	Construction Augers	355
Canvas Tool Buckets	86, 92	Cooler	158
Capstan Hoists	191–194, 192–195	Cover-Up Equipment	137–142
Captain Roller	229	Crimping Hand Tools	288
Captive Pin Clevis	230	Crossarm Brackets	230
Carabiners	71	Crossarm Covers	140
Catch Off Grips	196–204	Crossarm Sling	331
Caution Tape	148	Cushion Wrap Pad	69, 122
Chain Hoist	182–183, 183–184	Custom Ground Sets	252–254
Chain Pole Slings	181, 356	Cutout Covers	137
Chainsaws	79–83	Cutting Pliers	16
Chain Slings	181, 356		
Chamfer Tool	370	D	
Channel Lock Pliers	16	Deadend Cover	138
Chaps	85	Demolition Hammer	56
Chicago Grips	197–201	Demolition Screwdrivers	18
Clamp Meters	341	Dewatering Pumps	367
Clear PVC Cover-Up	136, 142	Diagonal Cutting Pliers	16
Climber Accessories	67	Digging Bar	359
Climber Guards	123	Digging Tools	359
Climber Pads	68–70, 121–122	Digital Ammeter	345
Climber Shield	67, 123	Digital Multimeters	342
Climber Sleeve Fasteners	67, 124	Digital Torque Indicator	354
Climber Sleeves	67, 124	Digital Voltage Indicator	338
Climbers Sets	66	Dirt Skirt	363
Climber Straps	123	Distribution Wrenches	9
Clipping Hook	239	Diving Board	329
Cluster Bar	258	Double Acting Hydraulic Pump	312
Cluster Bracket	258	Double Square Sockets	43
Collapsible Cable Reel	163	Drawbar	160
Collapsible Reel Part Breakdown	386	Drawknife	21
Combination Ratchet Wrenches	4	Draw Knives	363
Compression Adapters	310	Drill Bits	40–41
Compression Dies	310	Drive End Wrench	352
Compression Tools	288–309	Drive Tools	352–355
Conductor Brushes	259	Dua Pull Grips	209–211
Conductor Cover	138–139	Duct Adapters	382

Duct Mandrels	377–378	Frost Bar	359
Duct Projectiles	376	Fuse Puller	334
E		G	
Earth Augers	355	Gaff Finishing Hone	67
Elbow Adapter	347	Gaff Guards	125
Elbow Grippers	328	Gas Powered Driver	56
Elbow Grounds	253	Gas Powered Engine Drills	47
Elbow Puller	328	Gas Powered Pruner	84
Equipotential Ground Mats	256–257	Glove Bags	134
Erection Wrenches	2	Glove Inflator	132
Extension Arms	330	Glove Liners	132
Extension Resistor	346–347	Gloves	130
Extension Wrenches	352–353	Goat Wrenches	1
EZ Squeeze	116	Go Lights	150
F		Grip All Sticks	320–321
Fall Protection	98	Grip Cleaning Brushes	204
Fault Locators	350–351	Ground Cable	250
Feed Sheaves	381	Ground Clamps	247–248
Feed Tubes	209, 211	Grounded Stringing Blocks	236
Ferrules	243, 249	Ground Ferrules	243, 249
Fiberglass Probe	362	Ground Flags	148
Fiberglass Tapes	19	Ground Grids	256–257
Figure 8 Device	72	Grounding Attachments	236
First Aid Kit	158	Grounding Reels	164, 255
Flags	159	Ground Protection Mats	161
Flexible Cable Guides	382	Ground Resistance Tester	337
Flexible Conductor Brush	259	Ground Rod Cutter	273–277
Flexible Steel Mandrel	377	Ground Rod Driver	56–57, 258
Flex Wrench	11	Ground Rod Driver Bits	59
Flipline	70	Ground Sets	251–255
Foam Carriers	376	Guy Wire Cutter	269, 271
Folding Hex-Key Wrenches	19	Guy Wire Dispenser	163
Folding Rules	19	Guy Wire Grips	199–200
Foot Plates	123	H	
Foot Straps	123	Hammer Drills	48–54
Footwear	126–127	Hammers	17
Fork Truck Hitch Adapter	173	Hand Brace	40

INDEX

Handheld Hydraulic Cutting Tools	273	Hydraulic Impact Wrench Accessories	32–33
Handline Blocks	169	Hydraulic Impact Wrench Assembly	31
Handline Rope	170	Hydraulic Impact Wrenches	30–31
Hand Wipes	158	Hydraulic Intensifiers & Control Valves	315
Hard Hats	156	Hydraulic Pole Puller	365
Harnesses	99–108	Hydraulic Pole Saws	79–80
Headlamps	156	Hydraulic Pole Tamper	364
Heavy Duty Lifting Tongs	357	Hydraulic Power Units	61, 313, 365
Helicopter Stringing Blocks	234	Hydraulic Pruners	80
Hex-Key Wrenche	19	Hydraulic Water Pumps	367
High-Pressure Hydraulic Couplers	312		
High-Pressure Hydraulic Hose	312	I	
Hinged Shotgun Sticks	320–321	Ice Cleats	127
Hi-Pot Adapter	346–347	Impact Adapters	33
Hold Card Tag Holder	148	Impact Pole Bits	40–41
Hole Hawgs	45	Impact Sockets	14–15
Hooked Hanger Sheaves	381	Impact Wrench Accessories	32, 33
Hook Ladders	329	Impact Wrenches	
Hot Arm Insulators	330	Battery Powered	34–39
Hot Arms	330–331	Hydraulic	30–31
Hot Rodder Tool	334	Impulse Phasing Tester	349
Hot Stick Cutters	27	Induction Coupler	351
Hot Sticks	27, 320–328	Innerduct Cutter	385
Hurt Man Bucket Truck Rescue System	98	Innerduct Jacket Slitter	385
Hydraulic Breaker Attachments	59	Innerduct Pulling Eyes	384
Hydraulic Breakers & Drivers	57–58	Innerduct Seal-Offs	376
Hydraulic Chainsaws	79–81	Innerduct Slitter	385
Hydraulic Compression Tools	307–309	Insect Repellent	158
Hydraulic Couplers		Installation Tool for SS5/SS150	352
High-Pressure	312	Insulated Blankets	135
Low-Pressure	32, 60	Insulated Cable Cutters	27
Hydraulic Cutting Tools	287	Insulated Hand Tools	24
Hydraulic Digger	57	Insulated Hanger	258
Hydraulic Flow Control Valve	62, 315	Insulated Hydraulic Cable Cutters	27
Hydraulic Ground Rod Drivers	57	Insulated Platform	329
Hydraulic Hoses		Insulated Ratchet Wrenches	11
High-Pressure	312	Insulated Skinning Knife	21
Low-Pressure	32, 60, 314	Insulator Bracket	230
Hydraulic Impact Wrench	30	Isolated Bug Wrenches	7

INDEX

Isolated Shaft Extensions	26	Load Straps	160
Isolated Wrenches	7–8	Locators	349–351
J		Locking Dog Assembly	352–353
Jack Jumper	246	Locking Snaps	72
Jack Straps	172	Log Chains	160
Jamb Skid	383	Long Reach Insulated Tools	27
Jumper Clamps	243	Lubricant Application Tool Kit	242
Jumper Leads	245	M	
Jumper Sets	244	Magnetic Drill Accessories	46
K		Magnetic Drills	45
Kellem Grips	210–211	Magnetic Locator	349
Kelly Bar Adapters	352–353	Manhole Guard Rail	385
Klein Grips	197–204	Manhole Hooks	385
Klein Pliers	16	Manhole Shield	385
Knife Sharpeners	23	Manual Compression Tools	288–289
L		Manual Ground Rod Driver	258
Lamp Changer	335	Measuring Sticks	324
Lanyards	102–103	Measuring Wheels	149
Leather Protectors	132	Mega Beast	339
Lifting Tongs	357	Mesh Pulling Grips	208–211
Lights	150–154	Micro Pulley	72
Line Carriers	376	Mud Bucket	358
Line Hose	137, 141	Multiple Pulling Harness	379
Line Hose Bag	90	Multi Tools	20
Lineman's Pliers	16	N	
Lineman's Tool Bags	91	Needle Nose Pliers	16
Lineman's Wrenches	1	Non-Rotating Connectors	213
Liners	130	Non-Rotating Swivels	213
Link Sticks	190	No-Wrench Anchor Tool	354
LiteBox	151	Nut & Bolt Pouches	114
LiteBox Accessories	152	Nut Drivers	18
Live Front Grounds	254	Nut Runner	42
Load Binders	160	Nylon Cable Protector	381
Load Break Bushing Adapter	346–347	Nylon Slings	174–176
Load Break Tools	245–246	O	
Load-Pickup Tools	246	OPGW Grips	208

Outrigger Pads	162	Power Dart Blower	376
Oval Tool Buckets	92	Power Pole Bits	40
P			
Payout Reel	163	Probe Insertion Tool	370
Peavies	360	Proximity Voltage Detector	338
Penta Buster	5	Pruning Saws	74–78
Penta Driver	43	Pulling Eyes	181, 356
Penta Socket	43	Pulling Harness	379
Penta Wrenches	5	Pulling Hook	181, 356
Personal Protection	85	Pumps	
Personal Voltage Detector	338	Trash	367
Phase Sequence Indicator	337	Water	367
Phasing Sticks	346–348	Punches & Dies	44
Phillips Screwdrivers	18	PVC & Polyethylene Cutter	385
Photo Cell Tester	335	PVC Roll Cover-Up	142
Pike Poles	358	Q	
Pilot Pins	46	Quick Check Load Device	340
Pin Top Stringing Blocks	230	R	
Plastic Covers	137–141	Rain Gear	128
Platform Boards	329	Range Finder	149
Pliers	16	Ratchet Cable Cutters	28–29, 269–271
Pocketbook Grips	205	Ratchet Straps	160
Pocket Knives	22	Ratchet Torque Wrenches	11
Pocket Thermometer	240	Ratchet Wrenches	4, 6–8
Pole Binder	160	Reel Thing	173
Pole Buddy	331	Repair Parts	
Pole Chains	181, 356	176-A-78 Cable Reel	386
Pole Climber Accessories	124–125, 125–126	6990FS Ratchet Cutter	387
Pole Covers	140	8690 Ratchet Cutter	388–389
Pole Cradle	360	EDR-210 Gas Engine Drill	390–393
Pole Dolly with Roller Cradle	366	EDR-260 Gas Engine Drill	394–397
Pole Light	159	PSC-1 & PSC-2 ACSR Trimmer	398
Pole Pullers	365	TE200 Ratchet Cutter	399
Pole Setting Tools	358–364	TE556 Ratchet Cutter	400
Pole Tampers	359, 364	DNAB-1 Crossarm Bracket	401
Pole Tongs	357	DNAB-2 Crossarm Bracket	402
Port-A-Wraps	73	DNBG12 Grounding Attachment	415
Post Hole Diggers	359	DNBG16 Grounding Attachment	416

INDEX

DNBG22-28 Grounding Attachment	417	Sag Scope	239
DNBGV22-28 Grounding Attachment	418, 419, 420	Sagwatch	240
DNCB-1 7" Universal Stringing Block	403	Screwdrivers	18
DNCB-2 7" Universal Stringing Block	404	Seal-Off Valve Body	376
DNRB3222 Radius Block	405	Secondary Cable Stripper	370
DNSB16U Stringing Block	406	Self Rescue System	98
DNSB22U Stringing Block	407	Semi-Con Scorer	369
DNSB28U Stringing Block	408	Service Tester	340
DNSBW22U Stringing Block	409	Shackles	175
DNSBW28U Stringing Block	410	Shear Pin Torque Limiter	354
DNSBW42U Stringing Block	411	Short Rubber Slug	376
DNTG75-2HD Traveling Ground	412	Shotgun Sticks	320-321
DNTG250-1625 Traveling Ground (New)	413	Shovels	359-360
DNTG250-1625 Traveling Ground (Old)	414	Signs	143-145
Replacement Gaffs	125	Sign Stands	144-145
Reusable Pulling Eyes	379	Single Acting Hydraulic Pump	312
Rigging Equipment	72-73	Single Conduit Seal-Offs	376
Roller Cradle Assembly	366	Slack Blocks	172
Rope	216-221	Sledge Hammers	17
Rope Accessories	222-223	Sleeve Buttons	133
Rope Hoist	189	Sleeve Harness	133
Rope Lanyard	70, 118	Sleeve Strap	133
Rotating Ground Adapter	164, 255	Slings	174-180
Rotation Meter	337	Slugging Wrenches	4
Rubber Blankets	135	Sockets, 1/2" Drive	12-15
Rubber Boots	126	Socket Set	14-16
Rubber Duct Projectiles	376	Soft Cable Cutter	28, 269
Rubber Duct Swab	378	Solenoid Tester	337
Rubber Glove Accessories	132	Sonde	351
Rubber Gloves	131	Spades	359-360
Rubber Sleeves	133	Specialty Ground Sets	253-254
Rubber Slug	377	Speed Stripper	369
Rulers	19	Spiking Tool	248
		Split Bells	382
		Split Handle Diggers	359
		Spoons	359
		Spotlights	151-153
		Spud Bar	359
		Spud Wrenches	3
S			
Safety Finger	334		
Safety Hook	230		
Safety Shirts	155		
Sagometer	240		

V		NOTES
V-Brushes	259	
Ventilators	368	
Vinyl Gear Bags	89	
Vise Grips	1	
Voltage Break Indicator	340	
Voltage Detector	338–345	
W		
Water Cooler	158	
Water Pumps	367	
Wedge Grips	203	
Wejtap Tools	316–317	
Wheel Chocks	159	
Wide Throat Grounded Stringing Blocks	236	
Wide Throat Helicopter Blocks	235	
Wide Throat Stringing Blocks	233	
Wiggy	337	
Winch Line	221	
Winch Line Blowers	376	
Wire Baskets	226	
Wire Brush Mandrel	377	
Wire Dispenser	163	
Wire-Holding Sticks	328	
Wire Pulling Grips	196–210	
Wire Rope Cutters	268	
Wood Shell Blocks	165	
Wood Test Mandrels	378	
Work Gloves	130	
Work Zone Lighting	150–154	
Y		
Y-Ball Clevis	230	

NOTES

NOTES

NOTES

ACSR WIRE CHART

CODE WORD	SIZE (AWG OR KCM)	STRANDING	COMPLETE CABLE DIAMETER	CODE WORD	SIZE (AWG OR KCM)	STRANDING	COMPLETE CABLE DIAMETER
Turkey	6	6/1	.198	Redwing	715.5	30/19	1.081
Swan	4	6/1	.250	Coot	795.5	36/1	1.040
Swanate	4	7/1	.257	Cuckoo	795.0	24/7	1.092
Sparrow	2	6/1	.316	Drake	795.0	26/7	1.107
Sparate	2	7/1	.325	Tern	795.0	45/7	1.063
Robin	1	6/1	.354	Condor	795.0	54/7	1.092
Raven	1/0	6/1	.398	Mallard	795.0	30/19	1.140
Quail	2/0	6/1	.447	Ruddy	900.0	45/7	1.131
Pigeon	3/0	6/1	.502	Canary	900.0	54/7	1.162
Penguin	4/0	6/1	.563	Rail	954.0	45/7	1.165
Waxwing	266.8	18/1	.609	Cardinal	954.0	54/7	1.196
Partridge	266.8	26/7	.642	Ortolan	1033.5	45/7	1.212
Ostrich	300.0	26/7	.680	Curlew	1033.5	54/7	1.245
Merlin	336.4	18/1	.684	Bluejay	1113.0	45/7	1.258
Linnet	336.4	26/7	.720	Finch	1113.0	54/19	1.292
Oriole	336.4	30/7	.741	Bunting	1192.5	45/7	1.302
Chickadee	397.5	18/1	.743	Grackle	1192.5	54/19	1.337
Brant	397.5	24/7	.772	Bittern	1272.0	45/7	1.345
Ibis	397.5	26/7	.783	Pheasant	1272.0	54/19	1.381
Lark	397.5	30/7	.806	Dipper	1351.5	45/7	1.386
Pelican	477.0	18/1	.814	Martin	1351.5	54/19	1.424
Flicker	477.0	24/7	.846	Bobolink	1431.0	45/7	1.427
Hawk	477.0	26/7	.858	Plover	1431.0	54/19	1.465
Hen	477.0	30/7	.883	Nuthatch	1510.5	45/7	1.466
Osprey	556.5	18/1	.879	Parrot	1510.5	54/19	1.505
Parakeet	556.5	24/7	.914	Lapwing	1590.0	45/7	1.504
Dove	556.5	26/7	.927	Falcon	1590.0	51/19	1.544
Eagle	556.5	30/7	.953	Chukar	1780.0	84/19	1.602
Peacock	605.0	24/7	.953	Bluebird	2156.0	84/19	1.762
Squab	605.0	26/7	.966	Kiwi	2167.0	72/7	1.735
Teal	605.0	30/19	.994	HIGH MECHANICAL STRENGTH			
Wood Duck	605.0	30/7	.994	Grouse	80.0	8/1	.367
Kingbird	636.0	18/1	.940	Petrel	101.8	12/7	.461
Swift	636.0	36/1	.930	Minorca	110.8	12/7	.481
Rook	636.0	24/7	.977	Leghorn	134.6	12/7	.530
Grosbeak	636.0	26/7	.991	Guinea	159.0	12/7	.576
Egret	636.0	30/19	1.019	Dotterel	176.9	12/7	.607
Scoter	636.0	30/7	1.019	Dorking	190.8	12/7	.630
Flamingo	666.6	24/7	1.000	Brahma	203.2	16/19	.714
Stilt	715.5	24/7	1.036	Cochin	211.3	12/7	.664
Starling	715.5	26/7	1.051				



TOOL SALES & TOOL RENTAL

**668 South County Line Road
Bensenville, Illinois 60106**

U.S. Toll Free: 877-860-5666

Phone: 630-860-5666

Fax: 630-860-5669

sales@tallmanequipment.com

TOOL REPAIR

**6440 South International Dr,
Columbus, Indiana 47201**

U.S. Toll Free 888-342-1666

Phone: 812-342-1666

Fax: 812-342-2666

Ventas y Servicio

630-694-5853

ventas@tallmanequipment.com