

# OPERATION MANUAL



## REC-54M



### REC-54M: Gear-Driven Cable Cutter

Read and understand all of the instructions and safety information in this manual before operating or servicing this tool.



195 Internationale Blvd  
Glendale Heights, IL 60139  
Phone 800-860-6170  
Fax 800-345-3767  
[www.spartacogroup.com](http://www.spartacogroup.com)

## THANK YOU...

*for purchasing an Huskie Tools product. Our mission is to supply the finest steel cable connecting and cutting tools and cable-related products to the transmission and distribution markets. Huskie Tools products will represent state-of-the-art tools and be dependable and safe. All products will carry an unconditional guarantee to be free from defects and to perform as advertised.*

*Please take the time to read this manual carefully to learn how to correctly operate and maintain your tool.*

## Table of Contents

Registration/ Contents.....	2
Warranty.....	3
Safety.....	4
Kit Includes .....	5
Specifications.....	6
Operating Instructions .....	7
Operating Instructions .....	8
Operating Precautions .....	9
Breakdown.....	10
Parts List.....	11
TroubleShooting Guide.....	12

## Warranty

Huskie Tools products carry a warranty that makes us a leader in the tool industry. No other manufacturer dares to back its tools as we do.

All Huskie REC-SERIES battery operated products carry a 5 year warranty. The ECO-SERIES battery operated products carry a 1 year warranty. The BP-80 & BP-84 batteries carry a 5 year warranty from the date stamped on the battery. The BP-82 battery carries a 1 year warranty.

### PRODUCT WARRANTY

REC-Series battery operated products	5 Years
ECO-Series battery operated products	1 Years
Batteries (BP-80, BP-84)	5 years/ (BP-82) 1 year
Chargers (CH-90, CH-94)	5 Years

The warranty does not cover any damages incurred from a Huskie tool including damages to property, bodily injuries and lost wages resulting from such injuries. This warranty solely covers the repair or replacement of tools supplied by Huskie. These remedies are exclusive, and the total liability of Huskie Tools, LLC whether based on contract, warranty, negligence, indemnification, strict liability or otherwise, shall not exceed the purchase price of the tool. In no event shall Huskie Tools, LLC be liable for consequential, incidental or special damages.

HUSKIE TOOLS, LLC MAKES NO OTHER WARRANTIES OF ANY KIND, EXPRESSED OR IMPLIED, AND ALL IMPLIED WARRANTIES INCLUDING ANY WARRANTY OF MERCHANTABILITY AND FITNESS FOR A PARTICULAR PURPOSE ARE DISCLAIMED.

Huskie reserves the right to determine all warranty claims. Huskie will not warranty tools containing parts or batteries not originally supplied by Huskie. Failure due to misuse, improper maintenance, misapplication, not following instructions or warnings, abuse or repairs attempted by anyone other than Huskie Tools, LLC, or an authorized service center renders this warranty null and void.

### Repair and Warranty Claims

All claims must be sent to Huskie for inspection and authorization. A Return Goods Authorization (RGA) is required before shipping tools to Huskie. Secure the authorization by telephoning or writing to Huskie's main office with details of the claim. Non-warranty repairs are handled using the same procedure. Repairs exceeding 50 percent of the cost of a new tool will be advised before repairs are made.

### Payment Terms

Upon credit approval Huskie's standard payment terms are net-30 days. Visa, Mastercard, Discover and American Express are also accepted.

### Freight

All Huskie tools are FOB, Glendale Heights, Illinois. Goods will be shipped pre-paid and added, unless otherwise specified. Freight shipments over \$17,000 are pre-paid.

### Quotations

Special quantity quotations should be phoned in to discuss the scope of your tool requests.

### Complete Support Services

Our customers have direct access to us for training, service, and problem solving. As specialists in tools, we maintain a trained repair staff and a large stock of parts. This contrasts with many tool suppliers who carry tools as a sideline without offering support services. Here are some reasons why our customers love to do business with us:

- Quick delivery
- We maintain inventory at our headquarters.
- Training and troubleshooting services.
- Fast repair service.
- Design and engineering service for special tool needs.



**Safety Alert Symbol:**

This safety alert symbol indicates a potential personal injury hazard; it is not used for messages related to property damage only.



**Wear eye protection:**

when operating this tool. Failure to wear eye protection could result in serious eye injury from flying debris.



**Electric Shock hazard:**

Use proper personal protective equipment when using this unit on or near energized electrical lines.

**Pinch Point Hazard:**

Compression Dies at high force can cause severe personal injury. Keep all body parts away from moving parts of the tool while operating.





- 1 Battery Powered Tool
- 1 Carrying Case
- 1 CH-94 Charger
- 2 BP-84 Lithium Ion Batteries
- 1 Carrying Strap

### Battery and Charger

- BP-84 Huskie Tools Lithium Ion Battery
- CH-94 Huskie Tools Charger
- This charger can charge the BP-84, BP-82 and BP-80 only. Huskie Tools batteries, including the BP-70, BP-70E1 and the BP-70MH must be charged with the CH-90, CH-80, or previous charger models.



## REC-54M

### Specifications

Weight	8 lbs. with Battery
Size	15.5" L x 4.5" H x 5"W
Jaw Opening	2-1/8"

### Crimping Estimates

	BP-84
1590 MCM ACSR	35+

### Cutting Capacities

Copper	750 MCM
Aluminum	1500 MCM
ACSR	1590 MCM

### Features

- Improved Ergonomic Handle
- 2-1/8" Jaw Opening
- Cuts up to 1500 MCM Al
- One Hand Operation
- Safety Lockout Switch
- Upgraded Motor and Gear System
- 5 Year Warranty on Tool, Battery & Charger

The **REC-54M** is a heavy duty cable cutter primarily used to cut ACSR. It will cut up to 1590 MCM ACSR and copper cables up to 750 MCM. The large jaw opening will also accommodate aluminum cables up to 1500 MCM. Huskie Tools has notched both cutting blades to avoid the denting of the cutting surfaces when steel strand is encountered. We have rotated the handle 90° to the blade to achieve a more ergonomic and comfortable cutting position. This tool also incorporates a blade retainer, which keeps the blades from spreading apart while cutting steel cables. The REC-54M was designed for single and multi-stranded steel cores and aluminum cables. The powerful motor & gear drive allow the operator to cut through the toughest cables with just the pull of the trigger.

**NOTE:** The REC-54M is not intended to cut guy wires, ground rod or bolts. FOR CLEAN CUTS ON COPPER & ALL ALUMINUM CABLE PLEASE REFER THE REC-50M & THE REC-54ACM.

## CHARGING THE BATTERY

1. Insert the plug end into a 120V power source. The LED (Power) indicator will be steady green indicating the charger is now in "stand-by" mode and ready to charge the battery. Do not plug the charger into a generator as this will likely cause the fuse in the charger to short, and will not operate.
2. To charge a drained battery, insert the battery into the charger. The LED indicator shows a steady amber while charging. A depleted battery will be completely charged in approximately 50-70 minutes. The LED indicator will show a steady green when the battery is fully charged.
3. If the LED indicator goes out or is flashing quick amber, this could be a possible short in the battery circuit, or a problem with the charger itself. It is best to consult the factory at 1-800-860-6170 for service if such a condition occurs.
4. For technical questions or difficulty in operation, please call our customer service department at 1-800-860-6170.

## ATTACHING THE BATTERY CARTRIDGE

1. While pressing the latch, pull out the battery cartridge. To replace the battery cartridge, push the new cartridge firmly into place.
2. After inserting a battery cartridge, check that it is securely in place by pulling gently. Do not press the latch when pulling the cartridge.

## TRIGGER AND RELEASE BUTTON

1. The ram advances when the trigger is pressed and stops when the trigger is released.
2. To retract the ram, push the release button. The ram continues to retract while the release button is pressed.



## CUTTING

1. Select the appropriate control setting [Forward (A) or Reverse (B)] by activating toggle switch located above the trigger.
2. Be sure that material being cut is within the specified cutting capacity of the tool.
3. Place the material to be cut between the blades and press the advance trigger until blades hold the material in place.
4. Check material for proper alignment to the cutting blades. It should be at a 90° degree angle to the blades (C). Any other angle will cause the blades to spread apart and possibly break.
5. Continue to advance the blades until the material is cut. Once cut, select the Reverse on the toggle switch to retract the blades.

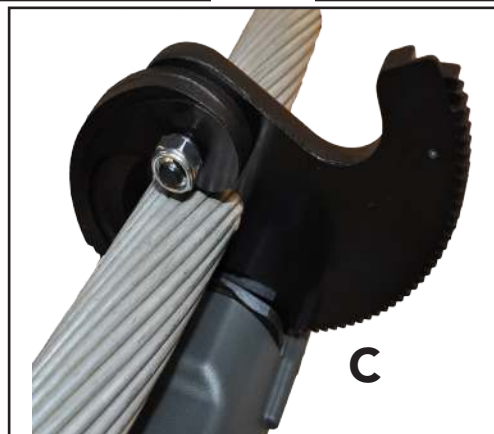
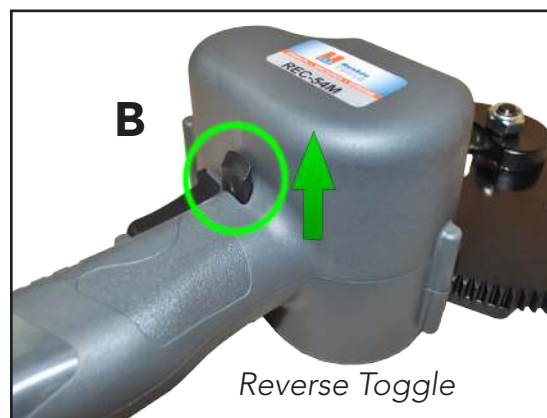
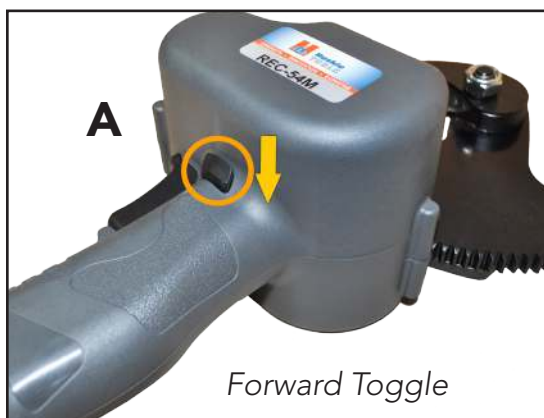

[All materials should be at a 90° angle to the blades as shown in figure C.]

## MAINTENANCE AND INSPECTION

1. Daily maintenance is required to ensure that the tool is kept in good working condition.
2. Sharpen blades occasionally with a sharpening stone on the back side of the blades to remove any burrs that may occur.
3. Do not store the tool in a humid environment.
4. Wipe away any excess oil with a soapy cloth.
5. Provided that maintenance of the tool is carried out regularly, the tool should provide many years of service.
6. Should you experience any difficulty with the operation and maintenance of this tool, contact Huskie's technical support department at 1-800-860-6170.



## PRECAUTION FOR THE TOOL

1. Always point the tool AWAY from other people.
2. If the tool is stored for an extended period at a temperature of less than 25° F (-5°C), the tool should be allowed to return to room temperature to ensure smooth operation Use the tool only after it has been at room temperature for 1 hour.
3. Do not drop the tool. Dropping the tool may damage the hydraulic circuit and result in the tool not functioning correctly.
4. Keep the head and ram clean and free of debris. Solvents can be used to clean the head, but should not be used on the plastic body. Use soap and water to clean the body.
5. Do not use tool for continuous use. If any sign of over heating, allow the tool to cool for 15 mins.
6. Do not allow tool to be submerged in water. The tool may be used in damp or wet environments. However it is recommended for tool to be air-dried before use.

## PRECAUTION FOR THE BATTERY CARTRIDGE

1. Do not short circuit the contacts or expose the cartridge to water, oil or solvents.
2. Do not disassemble or attempt to repair the battery cartridge or dispose of in a fire.
3. Do not drop or otherwise abuse the battery cartridge.
4. Do not leave the cartridge in locations where it will be exposed to a temperature greater than 140°F (60°C) for an extended period.
5. The battery has a limited life. When the crimping capacity becomes about 1/2 that of the original capacity, the battery should be replaced.
6. If the battery cartridge is stored without being charged, natural drainage will cause the power to be reduced. The battery should be charged every 3 months if not in use.

## PRECAUTION FOR THE CHARGER

1. The LED indicator lights up amber and remains lit when the unit starts charging a battery cartridge. The indicator turns green when charging is completed.
2. The BP-84 can be charged with any of the Huskie Lithium-Ion chargers including the CH-80, CH-90 & CH-94.
3. Allow battery cartridges to cool before charging. Allow at least 15 minutes between charges when charging several cartridges in succession.
4. Charge batteries at an ambient temperature of 50°-95°F (10°-35° C). Charging time is approximately 50-70 minutes for the BP-84.
5. Never short circuit the output terminals.
6. Do not expose the charger to water, oil or solvents.
7. Do not disassemble, attempt to modify, drop or otherwise abuse charger.

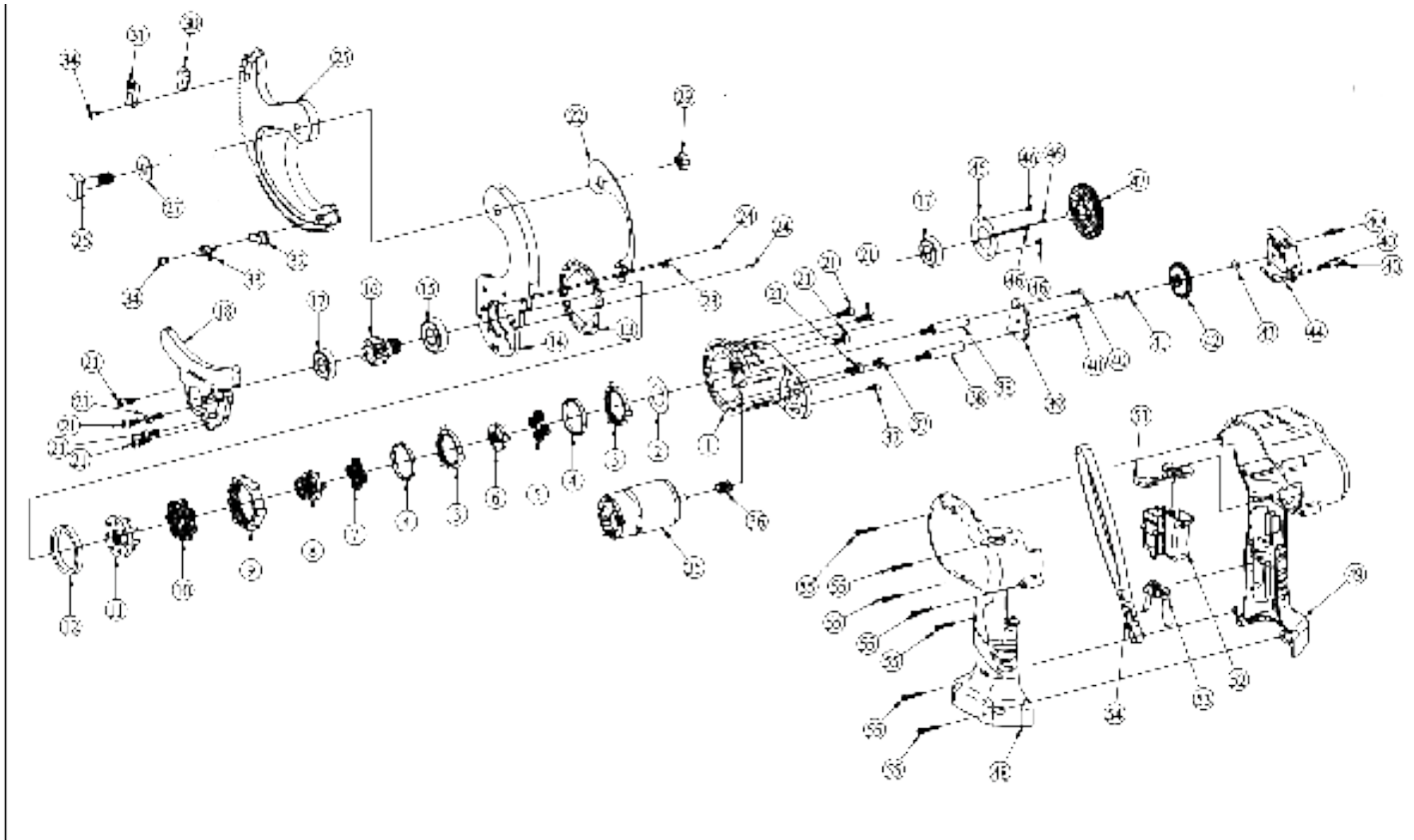

NO.	DESCRIPTION	CODE	QTY	NO.	DESCRIPTION	CODE	QTY
1	Gear Box	RCM-044	1	36	Motor Gear	RCM-044-1	1
2	Washer	RCM-043	1	37	Screw (M4 x 0.7 x 6L)	RCM-095	2
3	Ring Gear	RCM-042	2	38	Bolt	RCM-099	2
4	Rubber Washer	RCM-041	2	39	Gear Box Side Plate	RCM-098	1
5	First Gear Set	RCM-039	4	40	Screw (M3 x 0.5 x 8L)	RCM-061	5
6	First Gear Base	RCM-037	1	41	Axis	RCM-050	1
7	Second Gear Set	RCM-036	4	42	Gear	RCM-051	1
8	Second Gear Base	RCM-034	1	43	Axis Protector	RCM-096	1
9	Ring Gear	RCM-040	1	44	Back Cover	RCM-052	1
10	Third Gear Set	RCM-032	7	45	Fixed Plate	RCM-048	1
11	Third Gear Base	RCM-030	1	46	Screw (M3 x 0.5 x 5L)	RCM-062	4
12	Aluminum Ring	RCM-029	1	47	Gear	RCM-049	1
13	Washer	RCM-053	1	48	Housing Left	RCM-020	1
14	Fixed Blade for REC-54M	RCM-002	1	49	Housing Right	RCM-011	1
15	Bearing	RCM-006	1	50			
16	Pinion Gear	RCM-005	1	51	Adjusting Rod	RCM-054	1
17	Bearing	RCM-004	2	52	Switch	RCM-055	1
18	Bearing Base	RCM-003	1	53	Contact	RCM-018	1
19				54	Strap	RCM-056	1
20				55	Screw (M3 x 0.5 x 20L)	RCM-057	7
21	Screw (M5 x 0.8 x 12L)	RCM-024	9				
22	Protector	RCM-010	1				
23	Screw	RCM-026	1				
24	Pin	RCM-059	2				
25	Moveable Blade for REC-54M	RCM-001	1				
26	Shoulder Bolt	RCM-025	1				
27	Washer	RCM-063	1				
28							
29	Nut	RCM-064	1				
30	Spring Gear Base	RCM-009-1	1				
31	Spring Gear	RCM-009	1				
32	Spring Gear Base	RCM-008-1	1				
33	Spring Gear	RCM-008	1				
34	Screw (M4 x 0.7 x4L)	RCM-060	2				
35	Motor	RCM-013	1				

PROBLEM	CAUSE	SOLUTION
MOTOR RUNS, BUT THE TOOL JAWS WILL NOT ADVANCE	Insufficient Hydraulic Oil	Consult Factory for Repair Service
	Air Block in Hydraulic System	Invert tool to allow air to rise towards the top of the oil bladder
	Defective Hydraulic Circuit	Consult Factory for Repair Service
MOTOR RUNS, TOOL JAWS ADVANCE, BUT WILL NOT BUILD PRESSURE	Insufficient Hydraulic Oil	Consult Factory for Repair Service
	Defective Suction Valve or Bypass Cartridge	Consult Factory for Repair Service
MOTOR WILL NOT RUN AT ALL	Defective Battery	Charge or Replace Battery
	Bad Contact or Loose Battery Connections	Check all Connections and Wires
	Misaligned Switch	Check to Make Sure that Switch is Properly Aligned with Trigger
		Consult Factory for Repair Service
TOOL JAWS WILL NOT RELEASE	Tool Did Not Complete a Full Cycle and Bypass	Press Trigger and allow Tool to Bypass, Then Release Tool Jaws
	Connector is Jammed in Tool Jaws	Press and Hold Release Trigger While Prying Tool Jaws Apart
	Release Trigger is Bent or Misaligned	Consult Factory for Repair Service



## NOTES



## NOTES



## NOTES





195 Internationale Blvd  
Glendale Heights, IL 60139  
Phone 800-860-6170  
Fax 800-345-3767  
[www.spartacogroup.com](http://www.spartacogroup.com)